

1. Agenda

Documents:

[BOARD OF TRUSTEES AGENDA MAY 18, 2021.PDF](#)

2. Meeting Materials

Documents:

[TOWNSHIP BOARD AGENDA PACKET MAY 18, 2021.PDF](#)

[BOARD OF TRUSTEES AGENDA MAY 18, 2021 ZOOM MEETING NOTICE.PDF](#)



CHARTER TOWNSHIP OF GRAND BLANC
Township Board of Trustees
Agenda for Regular Meeting
Tuesday, May 18, 2021 at 7:00 p.m.

1. Call to Order
2. Roll Call
3. Approval of the Agenda
4. Public Comments
5. Privileged Presentation – The Board will hear a privileged presentation with Michael Barry from PFM on our investment performance review.
6. Approval of the Consent Agenda
 - a. The Board will consider a **Motion** for approval of Treasurer’s Financial Activity Recap for a Grand Total of **\$174,459.85**.
 - b. The Board will consider a motion to approve the purchase of 40 East Jordan Composite Castings from Michigan Pipe and Valve for \$27,808 and 40 steel plates from Hill Steel for \$2,359.62 for a total project cost of \$30,167.62 and authorize the Township Superintendent to execute all related purchase orders and documents.
7. New Business
 - a. The Board will hear a presentation regarding Code Enforcement.
 - b. The Board will hear from Chief Burdette regarding the Fire Department Year End Report.
 - c. The Board will hear from Chief Wiles regarding the Police Department Year End Report.
 - d. The Board will consider a Motion to approve the purchase of the AirHawk air purification system from Clean Air Concepts of Cincinnati, OH with installation at Fire Station #2 at 3313 E. Baldwin Road for \$24,766.00, and authorize the Township Superintendent to execute all related agreements and documents.

- e. The Board will consider a Motion to approve the agreement with ROWE PCS, the township engineer, for the Sherwood Drain bridge replacement design engineering proposal for the sum of no greater than \$19,500.00 and authorize the Township Superintendent to execute all related agreements and documents.

8. Future Agenda Items

9. Board Reports

Planning Commission – Sarah Hugo
Zoning Board of Appeals – Paul White
Metro Alliance – Joel Feick
Police Committee– Jude Rariden
Treasurer Mark Kilmer
Clerk David Robertson
Supervisor Scott Bennett
Attorney David Lattie
Superintendent Dennis Liimatta

10. Closed session if needed

11. Adjournment

Rules for Public Comment:

- Persons wishing to address the Board shall provide their name and mailing address.
- Individuals shall be allowed three (3) minutes. Associations or group representatives shall be allowed five (5) minutes.
- Time may not be yielded to other speakers.
- Speakers will address the Chairperson.
- Comments shall be made in a professional manner.



CHARTER TOWNSHIP OF GRAND BLANC
Township Board of Trustees
Agenda for Regular Meeting
Tuesday, May 18, 2021 at 7:00 p.m.

1. Call to Order
2. Roll Call
3. Approval of the Agenda
4. Public Comments
5. Privileged Presentation – The Board will hear a privileged presentation with Michael Barry from PFM on our investment performance review.
6. Approval of the Consent Agenda
 - a. The Board will consider a **Motion** for approval of Treasurer’s Financial Activity Recap for a Grand Total of **\$174,459.85**.
 - b. The Board will consider a motion to approve the purchase of 40 East Jordan Composite Castings from Michigan Pipe and Valve for \$27,808 and 40 steel plates from Hill Steel for \$2,359.62 for a total project cost of \$30,167.62 and authorize the Township Superintendent to execute all related purchase orders and documents.
7. New Business
 - a. The Board will hear a presentation regarding Code Enforcement.
 - b. The Board will hear from Chief Burdette regarding the Fire Department Year End Report.
 - c. The Board will hear from Chief Wiles regarding the Police Department Year End Report.
 - d. The Board will consider a Motion to approve the purchase of the AirHawk air purification system from Clean Air Concepts of Cincinnati, OH with installation at Fire Station #2 at 3313 E. Baldwin Road for \$24,766.00, and authorize the Township Superintendent to execute all related agreements and documents.

- e. The Board will consider a Motion to approve the agreement with ROWE PCS, the township engineer, for the Sherwood Drain bridge replacement design engineering proposal for the sum of no greater than \$19,500.00 and authorize the Township Superintendent to execute all related agreements and documents.

8. Future Agenda Items

9. Board Reports

Planning Commission – Sarah Hugo
Zoning Board of Appeals – Paul White
Metro Alliance – Joel Feick
Police Committee– Jude Rariden
Treasurer Mark Kilmer
Clerk David Robertson
Supervisor Scott Bennett
Attorney David Lattie
Superintendent Dennis Liimatta

10. Closed session if needed

11. Adjournment

Rules for Public Comment:

- Persons wishing to address the Board shall provide their name and mailing address.
- Individuals shall be allowed three (3) minutes. Associations or group representatives shall be allowed five (5) minutes.
- Time may not be yielded to other speakers.
- Speakers will address the Chairperson.
- Comments shall be made in a professional manner.

GRAND BLANC TOWNSHIP ~ FINANCIAL ACTIVITY RECAP
ACTIVITY for May, 2021 2nd Board Meeting

*****May 2021*****

Completed 5/13/21

Check #	Description	DATE	AMOUNT
	Payroll Disbursements		
Transfer	Health Equity Payment	4/23/21	\$ 262.66
Transfer	Health Equity Payment	5/5/21	\$ 108.00
Transfer	Health Equity Payment	5/7/21	\$ 105.83
	<u>Accounts Payable- Check Run</u>		
741(A)-750(A) 93112 93182	Accounts Payable- Check Run (Fund 101) \$121,464.47		\$ 173,983.36
	Accounts Payable-Check Run (Fund 208) \$8,177.21		
	Accounts Payable- Check Run (Fund 249) \$8,607.96		
	Accounts Payable-Check Run (Fund 592) \$35,733.72		
GRAND TOTAL			\$ 174,459.85
Reviewed By:			

05/13/2021 CHECK REGISTER FOR GRAND BLANC TOWNSHIP			
CHECK DATE FROM 05/19/2021 - 05/19/2021			
Check Date	Check	Vendor Name	Amount
Bank 110 TCF Bank- General			
05/19/2021	741(A)	AIRGAS GREAT LAKES	109.80
05/19/2021	742(A)	AL SERRA AUTO PLAZA	544.32
05/19/2021	743(A)	AMAZON CAPITAL SERVICES	496.20
05/19/2021	744(A)	CINTA'S CORPORATION #308	288.24
05/19/2021	745(A)	JOHNSON CONTROLS, INC	702.50
05/19/2021	746(A)	KYLE, MICHAEL	1,356.00
05/19/2021	747(A)	MAURERS TEXTILE RENTAL SERVICE	183.16
05/19/2021	748(A)	NET SOURCE ONE	871.88
05/19/2021	749(A)	RICOH USA, INC	724.32
05/19/2021	750(A)	SCZEPANSKI, THEODORE	1,545.00
05/19/2021	93112	ACCIDENT FUND OF MICHIGAN	21,060.06
05/19/2021	93113	ACE HARDWARE OF GRAND BLANC	100.80
05/19/2021	93114	APPLIED CONCEPTS, INC	202.00
05/19/2021	93115	ARC DOCUMENT SOLUTIONS, LLC	72.00
05/19/2021	93116	ASCENSION GENESYS HEALTH CLUB	399.00
05/19/2021	93117	AUTOZONE	165.11
05/19/2021	93118	BENISTAR/HARTFORD-6795	13,666.23
05/19/2021	93119	BETHANY BAPTIST CHURCH	250.00
05/19/2021	93120	BLUE CROSS/BLUE SHIELD	859.57
05/19/2021	93121	BLUE CROSS/BLUE SHIELD	18,664.27
05/19/2021	93122	C & S MOTORS, INC	2,885.58
05/19/2021	93123	CREDENTIAL CHECK CORORATION	75.00
05/19/2021	93124	DAVID MARTINEZ, JR	2,752.50
05/19/2021	93125	DBI	196.79
05/19/2021	93126	DELTA DENTAL PLAN	10,804.70
05/19/2021	93127	DIAMOND SPORTS GEAR	223.93
05/19/2021	93128	EMPCO, INC	1,650.00
05/19/2021	93129	ENVIRONMENTAL RUBBER RECYCLING	75.00
05/19/2021	93130	ESCON GROUP	520.00
05/19/2021	93131	ESCON GROUP	561.00
05/19/2021	93132	ETNA SUPPLY COMPANY	146.98
05/19/2021	93133	FERGUSON WATERWORKS	667.11
05/19/2021	93134	GALL'S, AN ARAMARK COMPANY	127.05
05/19/2021	93135	GENESEE COUNTY 9-1-1 CONSORTIUM	2,229.44
05/19/2021	93136	GENESEE COUNTY DRAIN COMMISSIONER	875.00
05/19/2021	93137	GILL ROY'S COMMERCIAL SUPPLY	70.38
05/19/2021	93138	GLC-LAB LLC	750.00
05/19/2021	93139	GRAINGER INC	131.83
05/19/2021	93140	GRAND BLANC COMMUNITY SCHOOLS	9,647.64
05/19/2021	93141	GRAND BLANC TOWNSHIP PETTYCASH PD	15.20
05/19/2021	93142	GRAND BLANC VETERINARY	58.00

05/19/2021	93143	HEMMES, SUSAN	241.96
05/19/2021	93144	HURLEY OCCUPATIONAL HEALTH PROGRAM	331.00
05/19/2021	93145	J & A HOLDINGS, LLC	1,045.00
05/19/2021	93146	JETSTREAM LANDSCAPE	1,382.00
05/19/2021	93147	LEAVY, DONALD	541.30
05/19/2021	93148	LEXISNEXIS RISK DATA MANAGEMENT INC	280.00
05/19/2021	93149	LISA DONALDSON	65.00
05/19/2021	93150	LISBETH YANCHO	65.00
05/19/2021	93151	MCCORMICK, SARAH	541.30
05/19/2021	93152	MICHIGAN ASSOC OF CHIEFS OF POLICE	1,000.00
05/19/2021	93153	MICHIGAN STATE POLICE	120.00
05/19/2021	93154	MILISSA ROBERTS	16.00
05/19/2021	93155	NELSON TANK ENGINEERING CONSUL	1,340.00
05/19/2021	93156	NORTH AMERICAN RESCUE, LLC	1,009.95
05/19/2021	93157	PEOPLEFACTS, LLC	95.11
05/19/2021	93158	PLANTE AND MORAN, LLP	38,160.00
05/19/2021	93159	PRO CLEAN - GRAND BLANC	446.25
05/19/2021	93160	PRO COMM INC	299.50
05/19/2021	93161	RICOH USA	922.35
05/19/2021	93162	ROCK BOTTOM STONE SUPPLY	209.50
05/19/2021	93163	ROSE PEST SOLUTIONS	73.00
05/19/2021	93164	SAM'S CLUB	297.52
05/19/2021	93165	SEELEY, DEVIN	38.99
05/19/2021	93166	SENTINEL TECHNOLOGIES, INC.	11,818.75
05/19/2021	93167	SHERWIN WILLIAMS CO	50.94
05/19/2021	93168	SHRED-IT USA	191.58
05/19/2021	93169	SIRCHIE LABORATORIES	554.60
05/19/2021	93170	SMITH, HANNAH	541.30
05/19/2021	93171	SOLOMON AND SON SHEET METAL ROOFING	2,110.00
05/19/2021	93172	SUBURBAN OFFICE & JANITORIAL	488.16
05/19/2021	93173	THIEL KIMBERLY	316.71
05/19/2021	93174	THOMAS, GLENN ALLEN	2,550.00
05/19/2021	93175	TREECE, MARY	46.46
05/19/2021	93176	TRUGREEN - FLINT 2784	1,675.51
05/19/2021	93177	UNIVERSAL LIFT PARTS	893.16
05/19/2021	93178	US BANK EQUIPMENT FINANCE	251.26
05/19/2021	93179	VIEW NEWSPAPER GROUP	3,688.00
05/19/2021	93180	WHITT, ALLYSON	35.00
05/19/2021	93181	WILLIAM E WALTER INC	2,255.25
05/19/2021	93182	WIRT SAGINAW STONE DOCK	1,272.36
110 TOTALS:			
Total of 81 Checks:			173,983.36
Less 0 Void Checks:			0.00
Total of 81 Disbursements:			173,983.36



CHARTER TOWNSHIP OF GRAND BLANC

DEPARTMENT OF PUBLIC SERVICES

Director ~ Jeffrey Sears

Date:	May 14, 2021
To:	Dennis Liimatta
From:	Jeff Sears, Director of Public Services
Re:	East Jordan Composite Castings

Dennis,

Asst. DPW Director Greg Boggs has been investigating the use of composite manhole casting and lids to be used in gravel roads. Right now, we use standard steel castings and lids. Over time, chloride used to control dust corrodes the steel making it very difficult to open the manholes in emergencies. The composite castings do not corrode and will be much easier to open.

We would like to purchase forty of these castings from Michigan Pipe and Valve for \$27,808.00. They were the lowest of three quotes obtained. Additionally, because they are made of composite material, we would like to purchase steel plates for \$2,359 which fasten to the lids so we can locate the manholes via metal detector. The steel plates will not affect the performance of the castings and lids. Please see Greg's memo attached herein for more information.

This is a planned expense in the sewer fund for 2021 from account 592-550-970.000.

AGENDA PLACEMENT:

Consent Agenda

RECOMMENDED MOTION:

The Board will consider a motion to approve the purchase of 40 East Jordan Composite Castings from Michigan Pipe and Valve for \$27,808 and 40 steel plates from Hill Steel for \$2,359.62 for a total project cost of \$30,167.62 and authorize the Township Superintendent to execute all related purchase orders and documents.

Best Regards,

Jeffrey Sears, *Director of Public Services*
Charter Township of Grand Blanc
Sears@twp.grand-blanc.mi.us
(810) 424-2640

CHARTER TOWNSHIP OF GRAND BLANC

5371 South Saginaw Street P.O. Box 1833 Grand Blanc, MI 48480-0057
810-424-2600 Fax 810-694-2881
www.twp.grand-blanc.mi.us

MEMORANDUM

DATE: 5/13/2021

TO: Jeffrey Sears, Director of Public Services

FROM: Gregory J. Boggs II, Assistant Director of Public Works

RE: ***EJ Composite Sanitary Sewer Frames and Covers***

Jeff,

During our Manhole Assessment Certification Program (MACP) that we did with the SAW grant over the last few years, we had difficulty accessing our sanitary manholes that are in the roadway in gravel roads. These manholes are left below grade, due to the type of maintenance that is needed to maintain a gravel road.

These accessibility issues aren't just because the manholes are left below grade. The industry standard for manholes are either cast iron or ductile iron. Part of the maintenance to gravel roads is dust control, which is applied via a chloride solution. Chloride is very corrosive and it eventually leeches down to our sanitary structures, either by moisture or road grading, causing heaving corrosion on our manhole covers, making them very difficult to open. In a sewer emergency, it takes extra time and manpower to expose these manholes that are buried, and spending extra time on trying to gaining access to corroded manholes could mean more damage to our residents and business owners properties.

A solution to the corrosion issues with the manhole frames and covers in gravel roads is to replace them with frames and covers made out of a composite material, that is designed to be resistant to corrosion, without losing the strength of cast iron. These new frame and covers that are made by EJ (East Jordan Iron Works), will make these structures better accessible for our Technicians, whether if it is for routine maintenance or emergencies. I also looked into custom steel plates from our local steel supplier. The plates will be laid over the composite manhole covers, so our Technicians will be able to locate the manholes with their magnetic locators. These plates will also help protect the composite covers from our excavator, when our Technician's need to unburied

We have identified 40 manhole structures in gravel roads that will need to be converted, so I reached out to 3 of our waterworks suppliers for pricing on these EJ composite frames and covers, Ferguson Waterworks, Michigan Pipe and Valve, and Core and Main. Michigan Pipe and Valve was the cheapest vendor for the Frames at \$27,808.00. Ferguson Waterworks pricing was \$28,374.00, and Core and Main was \$29,270.00. For the steel plates, I reached out to the local steel supplier, Hill Steel for pricing on custom 3/16" thick, 24" round steel plates. The cost of these plates is \$2,051.85 and is based on current market steel pricing.



Scott Bennett, *Supervisor*

Dave Robertson, *Clerk* Mark Kilmer, *Treasurer*

Trustees: Joel Feick Sarah Hugo Jude Rariden Paul White

Dennis Liimatta, *Superintendent*

CHARTER TOWNSHIP OF GRAND BLANC

5371 South Saginaw Street P.O. Box 1833 Grand Blanc, MI 48480-0057
810-424-2600 Fax 810-694-2881
www.twp.grand-blanc.mi.us

I recommend we purchase 40 EJ Composite Sanitary Manhole Frames and Covers from Michigan Pipe and Valve, and 40 round 24" steel plates from Hill Steel for the amount not exceed \$30,167.62.

I added 15% to the cost of the steel plates, due to the volatile steel market.

Let me know if you have any questions.

Thank you,

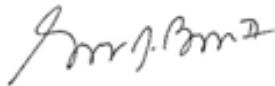

Gregory J. Boggs II, S-1 D-4

Assistant Director of Public Works

Office: [810.424.2640](tel:810.424.2640)

Email: boggs@twp.grand-blanc.mi.us



Scott Bennett, *Supervisor*

Dave Robertson, *Clerk* Mark Kilmer, *Treasurer*

Trustees: Joel Feick Sarah Hugo Jude Rariden Paul White

Dennis Liimatta, *Superintendent*

MICHIGAN PIPE & VALVE

FOR ALL YOUR WATER, STORM AND SEWER NEEDS

PRICE QUOTE

SAGINAW 595 KOCHVILLE ROAD SAGINAW, MI 48604 PHONE (589) 752-7911 Saginaw@michiganpipe.com	JACKSON 3604 PAGE AVENUE JACKSON, MI 49203 PHONE (517) 764-9151 Jackson@michiganpipe.com	TRAVERSE CITY 487 W. WELCH COURT TRAVERSE CITY, MI 49686 PHONE (231) 929-7473 TraverseCity@michiganpipe.com	MT. PLEASANT 1314 S. MISSION ROAD MT. PLEASANT, MI 48858 PHONE (589) 817-4331 MTPleasant@michiganpipe.com	GENESEE 1217 E STANLEY RD MT MORRIS, MI 48158 PHONE (810) 547-7151 Genesee@michiganpipe.com
---	---	--	--	--

Page 1

Printed 05/11/21 RT

Quoted

GRAND BLANC TOWNSHIP
5371 SOUTH SAGINAW STREET
PO BOX 1833
GRAND BLANC MI 48480-0057
Tel:810-424-2600 Fax:

Ship To

COMPOSITE ASSEMBLY SANITARY

Quote # QG02423	Quote Date 05/04/2021	Exp Date 10/31/2021	Customer # 0001794	Customer P/O #	Ship Via	Writer RT
Job ID			Customer Terms NET 30		Salesman RICK THIELL	

Product	Description	UM	Quant	Unit Price	Extension
SP	41 BUSINESS DAYS FROM ORDER	EA	0	0.00	0.00
SP	2600 DUROSTREET COMP ASSY	EA	40	695.20	27808.00

X: _____ (Accepted by)	Sub Total	\$27,808.00	T o t a l \$27,808.00
	Freight	\$0.00	
	Misc Charges	\$0.00	
	Tax Amount	\$0.00	

MESSAGE

TERMS

QUOTE INFORMATION

PO #
GRAND BLANC TWP

Expiration Date
December 25, 2021

Job Name
EJ COMP2600

ITEMS IN YOUR QUOTE

#	Image	Product Code	Description	QTY	Net Price	Total Price
1.		SP-ECOM260263A01	COMP2600 DUROSTREET 4" TALL	40	\$709.35	\$28,374.00

SUBTOTAL

\$28,374.00

Quoted prices are based upon receipt of the total quantity for immediate shipment (48) hours. SHIPMENTS BEYOND 48 HOURS SHALL BE AT THE PRICE IN EFFECT AT THE TIME OF SHIPMENT UNLESS NOTED OTHERWISE. QUOTES FOR PRODUCTS SHIPPED FOR RESALE ARE NOT FIRM UNLESS NOTED OTHERWISE. CONTACT YOUR SALES REPRESENTATIVE IMMEDIATELY FOR ASSISTANCE WITH DBE/MBE/WBE/SMALL BUSINESS REQUIREMENTS.

www.ferguson.com

LEAD LAW WARNING: In accordance with the US Federal or other States laws It is illegal to install products that are not "lead free" certified in potable water systems anticipated for human consumption. Refer to your local plumbing inspector or manufacturer for more details.



Bid Proposal for Grand Blanc Twp Composite Assemblies

CHARTER TOWNSHIP GRAND BLANC

Job Location: Grand Blanc Twp, MI

Bid Date: 05/07/2021

Core & Main 1803297

Core & Main

6575 23 Mile Rd

Shelby Township, MI 48316

Phone: 586-323-8800

Fax: 586-323-8812

Seq#	Qty	Description	Units	Price	Ext Price
10					
20		**THIS QUOTE REPRESENTS OUR			
30		INTERPRETATION OF THE PLANS &			
40		SPECIFICATIONS AND IS OFFERED			
50		AS AN AID TO BIDDING ONLY.			
60		**SPECIAL ORDER ITEMS MAY NOT			
70		BE RETURNED WITHOUT APPROVAL**			
80		**THIS QUOTE IS BASED ON THE			
90		RECEIPT OF THE ENTIRE LIST OF			
100		MATERIAL. ANY DEVIATION COULD			
110		RESULT IN PRICE CHANGES.			
120		*****			
130		*****			
140		PLAN DATE:			
150		LAST REVISION:			
170	40	EJ 2600 DUROSTREET COMPOSITE ASSEMBLY COM260236A01	EA	731.75	29,270.00
				Sub Total	29,270.00
				Tax	0.00
				Total	29,270.00

Branch Terms:

DUCTILE PIPE & CONCRETE PIPE MAY BE PRICED FOR FACTORY DIRECT TO JOBSITE DELIVERY. DUCTILE PIPE & CONCRETE PIPE FROM CORE & MAIN YARD MAY BE BILLED AT A HIGHER PRICE. PAYMENT IS NOT CONTINGENT ON CLEANUPS. CLEANUPS ARE DONE AS A COURTESY AND AT CORE & MAIN'S DISCRETION. ASK US ABOUT FUSION RENTAL EQUIPMENT. # SPECIAL ORDER ITEMS ARE NON-RETURNABLE AND NOT SUBJECT TO CANCELLATION, HOWEVER WE WILL ADVISE IF MANUFACTURE IS WILLING TAKE BACK SUBJECT TO RESTOCK FEES AND FREIGHT CHARGES.

UNLESS OTHERWISE SPECIFIED HEREIN, PRICES QUOTED ARE VALID IF ACCEPTED BY CUSTOMER AND PRODUCTS ARE RELEASED BY CUSTOMER FOR MANUFACTURE WITHIN THIRTY (30) CALENDAR DAYS FROM THE DATE OF THIS QUOTATION. CORE & MAIN LP RESERVES THE RIGHT TO INCREASE PRICES UPON THIRTY (30) CALENDAR DAYS' NOTICE TO ADDRESS FACTORS, INCLUDING BUT NOT LIMITED TO, GOVERNMENT REGULATIONS, TARIFFS, TRANSPORTATION, FUEL AND RAW MATERIAL COSTS. DELIVERY WILL COMMENCE BASED UPON MANUFACTURER LEAD TIMES. ANY MATERIAL DELIVERIES DELAYED BEYOND MANUFACTURER LEAD TIMES MAY BE SUBJECT TO PRICE INCREASES AND/OR APPLICABLE STORAGE FEES. THIS BID PROPOSAL IS CONTINGENT UPON BUYER'S ACCEPTANCE OF SELLER'S TERMS AND CONDITIONS OF SALE, AS MODIFIED FROM TIME TO TIME, WHICH CAN BE FOUND AT: <https://coreandmain.com/TandC/>

QUOTE!
To: Mike



Builders Supplies, Inc.

6110 Birch Drive
Flint, Michigan 48507
Phone (810) 232-6194

CUSTOMER NAME: Grand Blanc Twp

JOB NAME: _____ JOB NUMBER _____

PRICE QUOTED: \$ 5170.55 DATE QUOTED 5-11-21 TELEPHONE NUMBER _____

Price Quote Good for 3 Days from 5-11-21

yuresko@twp.grand-blanc.mi.us

QUANTITY	MATERIAL	LENGTH	WEIGHT	
40	3/16" plate	24" X 24"		\$ 2051.85
40	3/16" plate	24" diam. circle		\$ 2051.85
40	3/16" plate	16" X 16"		\$ 1066.85
				Total = \$ 5170.55
Price Quote Good for 3 Days from 5-11-21				
Price Based on current market value				
Please allow 5-7 business days				
Price based on ordering all material at 1 time				
Thanks!				
Shannon				

DUROSTREET® Access Assembly

Roadway Applications

The DUROSTREET® Access Assembly has been designed for strength, durability, and ergonomics for heavy duty roadway applications. The optimized strength-to-weight design and one-person operation improves ease of access and overall worker safety. The integral cover and frame dampeners (around the edge of the cover and frame) protect the glass fiber reinforcement that spans the width of the cover.

Standard Features

- Heavy duty (H25)
- Excellent fatigue life— 2 million cycles at 16,000 lb of load*
- Superior wear and abrasion per ASTM D4060-14
- Cover dampener and frame dampener
- Color: black
- Pick bar made of 316 stainless steel
- Quarter turn paddle lock with penta head made of 316 stainless steel
- UV resistant— tested to ASTM G154-16 testing standard Cycle 1 for 1600 hours
- Five year limited warranty
- Made in the USA

Options

- Special lettering
- Custom logos
- Additional security locking
- Custom shapes: square or rectangular
- Custom diameters to fit existing frames
- Flame retardant resin
- AMR attachments
- Heat transfer protection

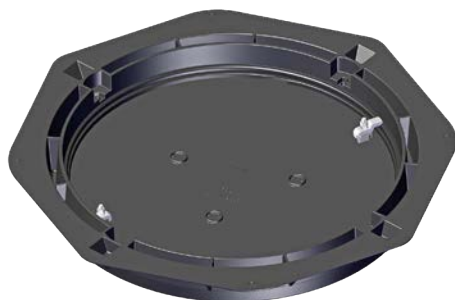

Bottom side view of the standard 30" clear opening frame and cover.

*See page 8 for load rating details



Illustrating the standard 30" clear opening frame and cover, which includes two quarter turn paddle locks and one pick bar.

DUROSTREET® Cover and Frame Dampeners

The DUROSTREET® Access Assembly features an integral cover dampener and frame dampener for strength and durability.

The dampeners, found around the perimeter of the cover and frame, are made of an extremely hard wearing polyurethane. They protect the glass fibers from wicking moisture, improve wear, and dampen traffic vibration.

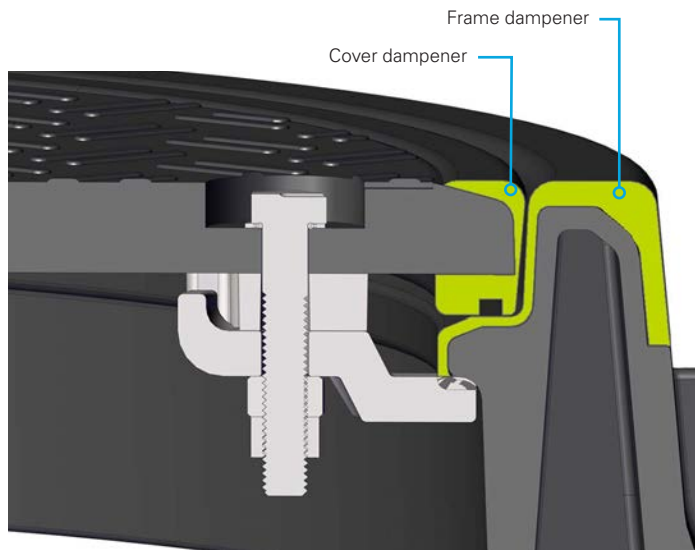

Illustrating a cutaway highlighting the cover and frame dampeners.



Cutaway showing the cover dampener around the outer edge (far right).

Quarter Turn Paddle Lock

The quarter turn paddle lock with 316 stainless steel penta head provides security by locking the cover in place when the paddle is turned to engage the frame.

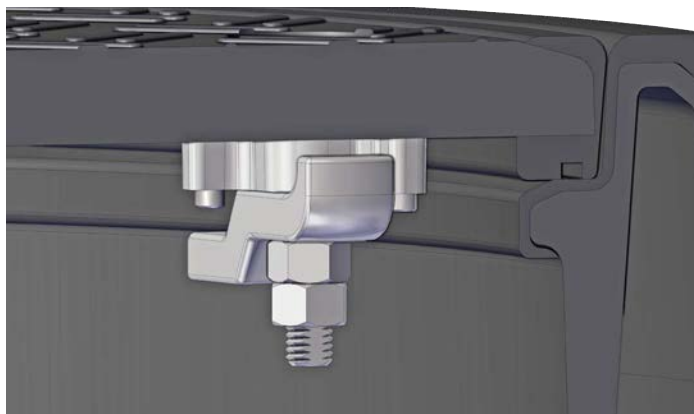

Quarter turn paddle lock illustrated in the open position.

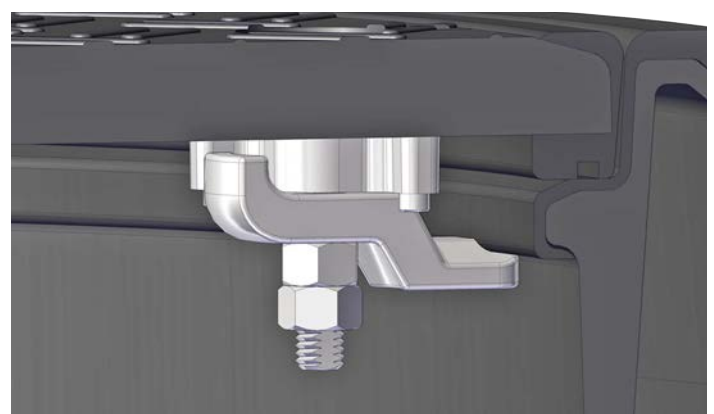

Quarter turn paddle lock illustrated in the closed position.

Ordinance Enforcement

Jeff Sears – Director of Public Services

Amy Wilkinson – Code Enforcement Officer/Office Clerk

Steve Hatfield – Part Time Code Enforcement Officer

Basics of Ordinance Enforcement

- The Code Enforcement Division is part of the Township's Public Services Department.
- Code Enforcement is responsible for enforcing the general ordinances of the Township such as junk, trash and debris, vehicles, weeds, etc. Zoning Ordinance issues such as signs, illegal structures and certain activities also fall under the purview of Code Enforcement.
- Our Code Enforcement services are typically provided Monday thru Friday. However, enforcement services are also provided on weekends and holidays as needed.
- Contacts:

Amy Wilkinson (Clerk, Inspector)	Steve Hatfield (Inspector)
810-424-2710	810-424-2698
Wilkinson@twp.grand-blanc.mi.us	Hatfield@twp.grand-blanc.mi.us
- In 2017, The Township increased its Code Enforcement Staff from one, part time Inspector to one full time clerk/inspector and one part time inspector.

Complaints

- The Township has adopted a policy requiring all complaints to be in writing for the Township to investigate.
- Residents can make complaints by:
 - Using the Public Service Request System on our website.
 - Download or pickup the Complaint Referral form and return in person or via e-mail to the Township.
 - Call our Offices and speak to a Staff Member
- Every complaint is investigated and resolved no matter the required resources to do so.

Investigations

- The Township tries to resolve every case quickly, through cooperation from the homeowner, using open communication and providing information about ordinances.
- Many times residents have no idea they are violating any kind of rule.
- Once a complaint has been received, the Township sends the property owner a letter informing them of the violation and informs them that they have 10 business days to resolve the issue.
 - In certain circumstances the Township will work with property owners to set a reasonable time frame for violations to be resolved if the work will take longer than ten days.
- If the property owner does not take care of the violation, The Township may issue the property owner a court appearance ticket. Once a ticket is issued a judge will determine if an order will be issued to correct the problem.

Grass and Weeds

- Township parcels must keep their grass and weeds under control at all times.
- Once grass and weeds exceed 8”, enforcement activities can commence if reported or found by Inspectors.
- These complaints are given 10 days to comply with grass cutting regulations.
- The Township will mow properties through our contractor (ACE Outdoor Services) after the 10 day period and within 24-48 hours of being requested.
- The Township charges the property owners \$165.00 per mowing which covers the actual service and administrative fees.
- If these fees are not paid, they can be placed on property taxes for collection.

Statistics for 2020 to YTD 2021

- Animal Related: 14
 - Grass and Weeds: 122
 - Inoperable Vehicle and Parking: 69
 - Work Performed w/out Permit: 49
 - Junk and Debris: 64
 - Boat and RV Parking: 74
 - Sign Violations/Complaints: 80
 - Un-inhabitable Structures: 9
- Only 14 cases required settlement in the court system.

Enforcement Activity

- Ordinance Enforcement Officers are mainly reactive to complaints.
- They do proactively patrol the Township for snipe sign violations removing signs whenever possible.
- While they are out an about, they do record obvious violations such as junk and debris issues or grass and weed violations.
 - Officers do not drive around specifically looking for these violations.
- Why are we not more proactive?
 - Ordinance Officers perform all their own clerical work such as tracking, data entry, sending letters, scheduling follow-up, answering phones, and returning voicemail and email messages.
 - Although the Township has invested more into Ordinance Enforcement in the past few years, budgetary constraints still exist and staffing shortages require split times in the office and in the field.
- Ordinance Officers do work weekends, on occasion, to patrol for illegal sign use.

Police and Ordinance Enforcement

The Police Department assists in Ordinance Enforcement when they are requested to by Township Staff or when a complaint is directly received through Dispatchers. Some of their most common calls for service are:

- Illegally parked boats/RV's
- Excessive Junk and Debris
- Unlicensed Vehicles
- Noise Complaints (Late night party's, barking dogs)
- In 2020, they received 51 code enforcement calls and 12 so far in 2021.



Grand Blanc Township Fire Department

53715 Saginaw St.
PO Box #1833
Grand Blanc, MI 48480-0057
Office: 810.694.7211
Fax: 810.694.9151

To: Board of Trustees

From: Bob Burdette, Fire Chief

Date: 5/7/2021

Subject: Purchase Approval

A bid request was submitted through Bidnet to vendors of Diesel Exhaust Filtration systems to be installed at 3313 E. Baldwin Road (fire station #2). On May 5 at 2:00 pm the bidding was closed and the submittals were opened. One vendor submitted a bid, Clean Air Concepts submitted a bid for the AirHawk Air Purification System. The manufacturer met the requested specifications on the bid.

Bid Tabulation:

Vendor	Manufacturer	Purchase Price
Clean Air Concepts	AirHawk	\$24,766.00

I am requesting approval to proceed with purchasing the AirHawk air purification system, using the funds approved through capital budget funds in 2021 for \$24,766.00

The manufacturer is providing a limited lifetime warranty as long the manufacturer's filters are used and replaced per their guideline.

Motion Request:

The board will consider a **Motion** to approve the purchase of the AirHawk air purification system from Clean Air Concepts of Cincinnati, OH with installation at 3313 E. Baldwin Rd. for \$24,766.00, and authorize the Township Superintendent to execute all related agreements and documents.

Robert Burdette
Fire Chief

Kent A. Maricle
Deputy Chief

DATE: April 29, 2021

PROPOSAL FOR: Grand Blanc Township Fire Department
3313 Baldwin Road
Grand Blanc, Michigan 48439

ATTENTION: Chief Robert Burdette

PROJECT SCOPE: Clean Air Concepts will provide and install an automatic **AirHAWK®** Air Purification System for the removal of vehicle exhaust emissions.

STATION #2
EQUIPMENT, MATERIAL & LABOR PRICE:

Please indicate desired system:

Minimum Industry Standard Equipment (system will provide 7 air changes per hour)

- _____ (3) **AirHAWK®** Model 2000XL Media Air Filtration Units with:
- 16 Gauge Cabinet (meets specifications)
 - 4" Pleated MERV 8 Pre-filter (meets MERV specifications, 4x larger filter size than specifications)
 - 12" MERV 16 Primary Filter (meets MERV specifications, 2x larger filter size than specifications)
 - 4" Gas Phase Filter – Blended Carbon, Potassium Permanganate and Zeolite (meets specifications)
 - 1 horsepower motor wired for single phase 208/230V (exceeds .75hp specifications)

PRICE.....\$20,949.00

OR

Recommended Equipment (system will provide 10 air changes per hour)

- _____ (4) **AirHAWK®** Model 2000XL Media Air Filtration Units with:
- 16 Gauge Cabinet (meets specifications)
 - 4" Pleated MERV 8 Pre-filter (meets MERV specifications, 4x larger filter size than specifications)
 - 12" MERV 16 Primary Filter (meets MERV specifications, 2x larger filter size than specifications)
 - 4" Gas Phase Filter – Blended Carbon, Potassium Permanganate and Zeolite (meets specifications)
 - 1 horsepower motor wired for single phase 208/230V (exceeds .75hp specifications)

PRICE.....\$24,766.00

Each System Also Includes:

- (1) 600626-01 1-6 Unit, 24V, Low Voltage Control Panel
- (2) 600701-01 Electric Photo Eye Assembly Sets

Labor and material to install units.

Electrical wiring from available supply to control panel and each **AirHAWK®** unit. Safety Subpanels are excluded, if required, and any modifications required to bring service to code are excluded.

Shipping to Job Site

Equipment is 100% American Made by an ISO9001-2015 Company

Women's Business Enterprise (WBE) Certified

Women's Owned Small Business (WOSB) Certified



MagneGrip Group

A DIVISION OF CLEAN AIR CONCEPTS

ACTIVATION OPTIONS:

Equipment priced above includes photo eyes that will activate equipment as apparatus pass through the bay doors. Either Magnetic Door Contact Sensors or Magnetic Door Flags will provide additional activation of equipment when the bay doors simply open.

Please Indicate Desired Option:

_____ (4) 600750-01 Magnetic Door Contact Sensors..... Add \$240.00 to Price

OR

_____ (4) 600705-10 Magnetic Door Flags (to break photo eye beam) Add \$84.00 to Price

Filter Pricing/Schedule:

Equipment comes with first set of filters upon installation. Filter pricing and typical schedule listed below:

4" Pleated MERV 8 Pre-filter (Change appx. every 6 months)	\$21.00
12" MERV 16 Primary Filter (Change appx. every 2 years)	\$325.00
4" Gas Phase Filter (Change every appx. 2 years)	\$225.00

TERMS:

- Pricing does not include any state, sales, or special taxes, if required.
- Upon approval, please submit a copy of this proposal and a tax exemption certificate.
- Net Due upon completion of project.

(Grand Blanc Twp, MI FD Proposal dated 4-29-2021)

SUBMITTED BY:

Clean Air Concepts

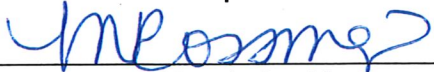

Maggie Rossman-Roach, President

04/30/21

Date

ACCEPTED BY:

Company: _____

Print: _____

Sign: _____

Title: _____

Date: _____

PO #, If Required: _____



AirHAWK 2000 Limited Lifetime Warranty

AN INDUSTRY FIRST: As manufacturer of the **AirHAWK 2000** Air Purification System, we are so proud and confident of our product and design, that we offer a Limited Lifetime Warranty*.

The Limited Lifetime Warranty applies to the **AirHAWK 2000** units, excluding replacement filters. Warranty terms are subject to the following conditions:

- Filters are to be replaced on the recommended scheduled basis and cannot exceed intervals determined by manufacturer.
- **AirHAWK** filters are proprietary in design and material composition, and are required to be purchased from the manufacturer or its authorized distributors.

*Limited Lifetime Warranty excludes misuse and abuse, natural disaster, war, acts of terrorism, and also excludes labor needed to make repairs. Parts must be returned "**pre-paid**" to the manufacturer for reconditioning or replacement at the manufacturer's discretion.

Manufacturer will "**pre-pay**" freight to return item to the customer. Service on the unit must be performed by a qualified technician. This warranty is limited to the original owner. All warranty information must be completed and returned to the manufacturer within 30 days of purchase and/or installation of unit(s) to ensure warranty activation.



MagneGrip Group
A Division of Clean Air Concepts
Cincinnati, Ohio USA

ISO 9001:2015 CERTIFIED



AirHAWK[®]

AIR PURIFICATION SYSTEMS

**BREATHE CLEAN AIR
WITHOUT PARTICULATES, TOXIC GASES, MICROBES AND VIRUSES**

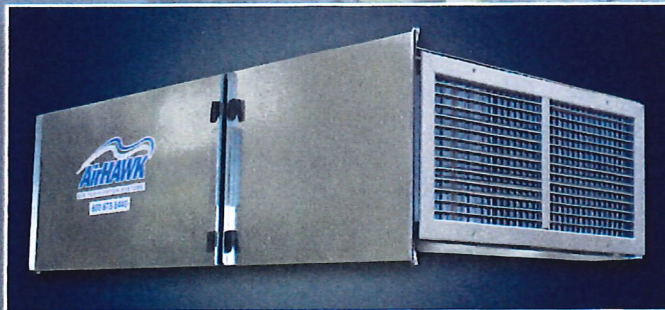

Protect First Responders' Health

When fighting fire, first responders protect themselves from toxins, soot, gases and fumes to avoid long term health concerns. In the firehouse, shouldn't they be protected against particulates and airborne viruses, bacteria and mold spores as well as toxins, soot, gases and fumes?

NFPA, EPA, NIOSH and most mechanical codes warn that diesel exhaust can cause serious health problems including cancer. The World Health Organization has classified diesel exhaust as a known carcinogen.

Diesel exhaust emissions have a mixture of different gases and some require special filtration materials for their removal. AirHAWK Air Purification Systems draw vehicle exhaust pollutants out of the air, trapping (or neutralizing) gases and particulates and then returning clean air to the facility.

The AirHAWK filtration process was developed by Sandia Laboratories and the National Renewable Energy Laboratory. This advanced technology, used by the US Department of Defense for destroying toxic organic compounds, is part of AirHAWK Air Purification Systems' units.



AirHAWK is your best choice

For fire/EMS facilities, most air cleaning systems remove particulates and some gas-phase pollutants that are released in diesel exhaust. AirHAWK offers the only system with the additional protection of Photo-Catalytic Oxidation and Ultraviolet Radiation to destroy toxic organic compounds (VOCs) and microbes. AirHAWK'S four-stage filtration process demonstrates why its air cleaning and purification performance is superior to all other systems.

30+ Years in Airflow Engineering Design

Unit placement and design of the air circulation pattern are critical to air purification and circulation effectiveness. The AirHAWK engineering team has more than 30 years of airflow design expertise. For each application, AirHAWK designs an effective air circulation pattern that provides continuous air purification and coverage for an entire area or facility.

No hoses, no hook ups, fully automatic

In the bay area, AirHAWK Air Purification Systems are ceiling mounted to avoid safety hazards. Hoses are not used and no vehicle or building modifications are needed. AirHAWK units are automatic and operate hands-free with no personnel interaction.

Meets or Exceeds Regulatory Standards

AirHAWK units meet or exceed the regulatory standards of NFPA, OASH, NIOSH, EPA and ASHRAE. AirHAWK is Assistance to Firefighters Grant compliant.

AirHAWK 3000 XL

Using the best technology available, energy-efficient AirHAWK 3000 XL removes more contaminants and disease-causing compounds than other air purification systems.



AirHAWK 3000 XL

LIMITED LIFETIME WARRANTY

Polluted air passes through AirHAWK 3000 XL's four-stage filtration process to remove harmful substances, such as particulates, toxic gases and other airborne contaminants. UV lamps kill viruses, bacteria and mold spores. Clean, purified air is then evenly dispersed back into the facility.

AirHAWK 2000 and AirHAWK 2000H units are also available.

Best Technology Features

- AirHAWK 3000 XL units are ETL certified to the UL 5-7 Standard and Canada Standard CSA C22.2.
- High efficiency blower motors: 1 hp PSC 208-230V or 1.75 hp ECM motor; 115/208-230V. Airflow: 2740/3000 CFM.
- Manual and remote activation features.
- System activation methods: Photo-Eye Sensors, Door Switches, Door Flags, CO/NO2 Sensors, Onboard Transmitters and other Custom Methods.
- Standard and Advanced Control panels for automatic operation.
- Illuminated "in operation" light and a separate indicator for filter replacement.
- 2-speed, 24/7 on-demand run capacity.
- Low amperage for low-cost efficiency.
- Ceiling-mounted.
- Meets or exceeds all regulatory standards: OSHA, NIOSH, EPA, ASHRAE.
- Also available:
 - AirHAWK 2000-H with .75 hp motor, 115V, 2000 CFM.
 - AirHAWK 2000 with 1 hp motor, 230V, 2740 CFM.



AirHAWK Has "Best Technology" Filtration

AirHAWK Air Purification Systems have a progressive filtration process that guarantees the highest level of pollution removal. With the most advanced air filtration

available, each unit provides four stages of filtration with our unique, patented Photo-Catalytic Oxidation (PCO) process.

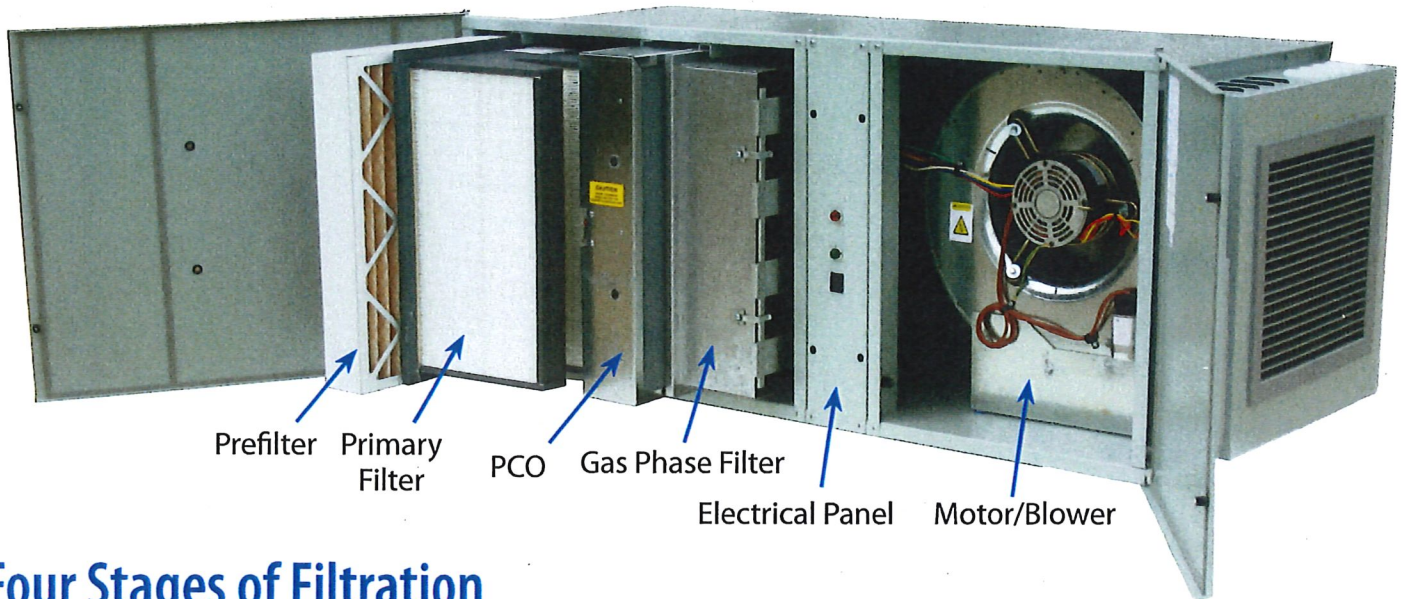

Four Stages of Filtration

- 1. Prefilter:** Hazardous exhaust emissions are drawn into the AirHAWK filtration unit by the motor blower assembly. A pleated filter removes diesel exhaust particulate and is rated class 2, UL Standard 900.
- 2. Primary Filter:** High-efficiency particulate (HEPA) filter has pleated, micro fiberglass media for high-capacity performance. Thermoplastic separators provide consistent spacing to ensure aerodynamic airflow.

- 3. Photo-Catalytic Oxidizer (PCO):** Containing both ultraviolet lamps and a patented, specially coated grid, PCO helps protect against microbes, mold spores, organic compounds and viral germs. Available on AirHAWK 3000 XL model.

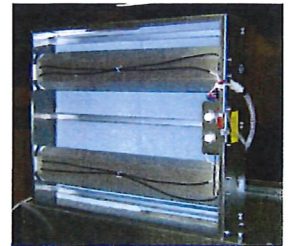

Photo-Catalytic Oxidizer

- 4. Gas-Phase Filter:** As the air reaches the gas-phase filter, the active carbon filter traps and absorbs volatile organic compounds (VOCs) to remove them from a facility's breathing area.



Control Panel

Standard Control Panel has these features: Automatic on/off, Manual Run / Manual Stop, Adjustable Timer, LED Display, Remote Activation.

Advanced or Custom Panel includes all Standard Control Panel features, plus: Email Alerts, Maintenance Notification, CO / NO2 Audible and Strobe Light Warning, Continuous Run 24/7 and On Demand Run, Remote Fan Operation and other Custom Features.



ROWE PROFESSIONAL SERVICES COMPANY

Large Firm Resources. Personal Attention.™

April 27, 2021

Mr. Patrick Linihan CPRP, CPSI, AFO
Director, Grand Blanc Parks and Recreation
Charter Township of Grand Blanc
5371 South Saginaw Street
PO Box 1833
Grand Blanc, MI 48480

RE: Creasey Bicentennial Park Sherwin Drain Bridge Replacement
Design Engineering Proposal

Dear Mr. Linihan:

Based on our discussions, we have provided the following proposal to assist with the evaluation and design of the pedestrian bridge at Creasey Bicentennial Park. Our services for this project will utilize the as-needed engineering contract coordinated through the township department of public works.

PROJECT UNDERSTANDING

In July 2020, ROWE completed a structure evaluation resulting in a recent recommendation to close this structure based on some failing wood members. The township would like to replace this structure as soon as possible to re-open access to walking paths within the park.

A study phase will evaluate options for a culvert, wood structure with concrete abutment, composite/fiberglass or hybrid wood structure with recycled composite decking. The study will identify construction cost along with long-term maintenance factors.

It should be noted that the permit review process for Michigan Department of Environment, Great Lakes, and Energy (EGLE) has currently taken up to 90 days minimum for approval. The watercourse is named as the Shermin Drain and downstream as the Carman Creek and will require review by Genesee County Drain Commissioner.

SCOPE OF SERVICES

Site Investigations

ROWE will visit the site with township staff and discuss proposed boardwalk details. Soil borings will not be completed. A topographic survey will be completed from the edge of the woods for construction access and cross sections will be completed as needed for a HY-8 hydraulic model for permitting.

Preliminary Design

Modeling to size a culvert option will be completed. Construction cost opinions for each concept will be provided. ROWE will schedule a meeting to review options and construction cost opinion information with the township. Upon approval of the selected option, ROWE will prepare a 60 percent plan set, details, an EGLE joint permit application, soil erosion and sedimentation control (SESC) permit, and building permit application for execution by the Contractor. Permit fees are not included in ROWE fees and will be paid directly by the township or as a direct reimbursement as additional services.

Engineering | Surveying | Aerial Photography/Mapping | Landscape Architecture | Planning

Corporate: The ROWE Building, 540 S. Saginaw Street, Suite 200 • Flint, MI 48502 • O (810) 341-7500 • F (810) 341-7573

With Offices In: Farmington Hills, MI • Grayling, MI • Kentwood, MI • Lapeer, MI • Mt. Pleasant, MI • Myrtle Beach, SC

www.rowepsc.com

Mr. Patrick Linihan CPRP, CPSI, AFO
April 27, 2021
Page 2

Final Design

Comments from the preliminary design phase will be addressed in a 90 percent construction document set. We will prepare a bidding documents which will include technical specifications. An updated construction cost opinion will be developed. ROWE will submit the 90 percent set of documents to the township for review.

Bidding and Award

ROWE will assist Grand Blanc Parks and Recreation with the advertisement of bids. During the bidding phase, we will address technical bid questions in the form of a bid clarification or addendum. If requested, we will attend the bid opening with the township. Once bids are received, we will review and provide a recommendation of award. Our schedule shows advertising the project concurrent with permit review, waiting for permit approval prior to award based on desire to fast-track the project.

Construction

Thirty (30) hours of construction assistance have been provided for a pre-bid meeting, shop drawing review, and progress meetings. However, ROWE can negotiate this scope to best meet the needs of the township.

ANTICIPATED PROJECT SCHEDULE

Notice of Award to ROWE	May 2021
Complete Site Investigations	June 2021
Complete Preliminary Design	July 2021
County Review Comments to ROWE	July 2021
Complete Final Design / Submit Permits	August 2021
Advertise for Bids	September 2021
Bid Opening	October 2021
Permit Approval / Award Contract	November 2021
Construction	November-December 2021

CLARIFICATIONS

- Daily construction observation is not included in our scope.
- Materials testing or construction staking is not included.

FEES

We proposed to perform the work itemized above for the following lump sum fee:

Task	Engineering Fee
Survey	\$2,200
Design / Permit Applications / Bidding	\$13,300
Construction Assistance	\$4,000
Total Fees	\$19,500

We look forward to working with you on this very important project. If you have additional questions relative to this proposal, please contact me at (810) 341-7500.

Sincerely,
ROWE Professional Services Company

Doug Schultz

Digitally signed by Doug Schultz.
DN: cn=US,
E=dschultz@rowepsc.com,
CN=Doug Schultz
Date: 2021.04.27 15:13:36-0400'

Douglas Schultz, PLA
Senior Project Manager

Mr. Patrick Linihan CPRP, CPSI, AFO
April 27, 2021
Page 3

Having reviewed this proposal, including the attached statement of terms and conditions which is a part thereof, acceptance of this proposal is hereby confirmed. ROWE Professional Services Company is authorized to proceed with the work.

Accepted by:

Signature

Date

Print Name and Title

Attachment

R:\sdsk\Proj\PROPOSAL\LANDARCH\Grand Blanc Twp\2021 projects\Sherwin Drain Bridge.docx

TERMS AND CONDITIONS

The Owner will designate a representative with the authority to provide direction, receive and review information, and make decisions regarding the project. Decisions and direction shall be provided in a timely manner, so as to not delay the project.

The Engineer will perform services in a timely manner, consistent with sound professional practice. The Engineer will strive to perform the services within the established schedule, if any. Services are considered to be complete when deliverables have been presented to the Owner.

The Owner will provide the Engineer with all available information pertinent to the site of the project and access to the project site.

The Engineer will assist the Owner in preparing applications and documents to secure approvals and permits. The Owner is responsible for payment of permit application fees and charges.

Services provided by the Engineer shall be performed with the care and skill normally exercised by other members of the profession practicing under similar conditions.

The Owner shall promptly notify the Engineer of defects or suspected defects in the work.

The Engineer's opinions of construction costs will be based upon experience and historical information.

The Engineer will be responsible for the safety precautions and programs of its employees only.

If the Engineer is reviewing work by contractors or others on behalf of the Owner, the Engineer may only recommend to the Owner that work which does not conform to the project requirements be rejected.

Payment for work completed shall be made within thirty days of invoicing. Unless otherwise provided, invoices will be submitted monthly as the work progresses.

In the event additional work is needed because of a change in scope or unforeseen conditions, the Engineer will submit a proposal defining the modified scope of work and any modifications to the schedule and fee for the Owner's approval.

This agreement may be terminated by either party with fourteen days' written notice; however, the Engineer shall be paid for work completed prior to the date of termination.

All documents prepared by the Engineer in completing this work are considered the Engineer's property as instruments of service and are not intended for re-use by the Owner or others.

The Engineer is an independent contractor, responsible to the Owner for the results of this undertaking and is not an employee or agent of the Owner.

The Owner agrees to limit ROWE Professional Services Company's total liability to the Owner and any contractors on the project to \$19,500 or the Engineer's fee, whichever is greater.

The Owner and Engineer each bind themselves and any partners, successors, and assigns of the other party to this agreement. Neither party will assign, sublet, or transfer their interest in this agreement without the consent of the other party.

The terms of this agreement shall be governed by the laws of the State of Michigan. In the event a provision of this agreement is rendered unlawful, the remaining terms and provisions shall remain in effect.

In performance of this work, the Engineer will comply with their policies regarding non-discrimination against employees on the basis of race, color, religion, national origin or ancestry, age or sex.

To: Grand Blanc Township Board of Trustees

Date: May 13, 2021

From: Patrick Linihan, Director of Parks and Recreation

Subject: Engineering for Bridge Design and Replacement

Lady and gentleman of the board. Before you today is a request for the approval of motion to proceed with engineering associated with the design and construction management of the replacement of the pedestrian bridge over the Sherwood Drain at Bicentennial Park.

Earlier this spring during an inspection of the bridge by ROWE PCS it was determined that structural issues were present and the bridge should be closed. This bridge is part of the hiking trails on the west side of the park and the closure greatly limits its access. ROWE PCS will do a survey and site investigation, preliminary design with cost estimates and a final design. Depending on if the work needs to be completed by a contractor ROWE PCS will assist in bid letting and construction assistance. The pricing assumes the additional work. If we are able to complete installation the price will be significantly less.

RECCOMENDED MOTION:

The Board will consider a motion to approve the agreement with ROWE PCS, the township engineer, for the Sherwood Drain bridge replacement design engineering proposal for the sum of no greater than \$19,500 and authorize the Township Superintendent to execute all documents.

Respectively,



Patrick D. Linihan CPRP, CPSI, AFO
Director of Parks and Recreation



Office: 810.694.0101
Fax: 810.424.2776



5371 South Saginaw St.
PO Box 1833
Grand Blanc, MI 48480



gbtpr@twp.grand-blanc.mi.us
gbparks.recdesk.com

Detective Bureau Report
March 2021

Rollover Accident / OWI

Officers were dispatched to I-75NB at Holly Road for a truck that had rolled over. Upon arrival the driver was found to have been ejected from the vehicle and was slow to respond. Initially he told officers there was a female passenger in the truck with him and one could not be located. After a search of the area including using a K-9, thermal camera, & a drone with a thermal camera no other occupants could be found. The suspect was taken to Genesys where it was confirmed by his parents that he was the lone occupant of the vehicle and his injuries consisted of a broken neck / back. Alcohol is believed to be a factor.

Motorist Assist / CCW

Officers noticed a broke down motorcycle and pulled over to provide assistance. The driver of the motorcycle was found to have no MC endorsement on his driver's license. The driver was arrested and after a search incident to arrest, an unregistered handgun was located. The driver was also a convicted felon and not supposed to be in possession of any firearms. After processing at the GBTPD the arrest was lodged at the Genesee County Jail.

Hit and Run Accident

An officer responded to an unknown accident. The officer located a single vehicle disabled in the roadway. The driver of the vehicle advised that the at-fault vehicle left the scene. The driver on scene had a warrant and was arrested however, the jail would not lodge and he was released. Officers later received information that the at-fault vehicle was seen at 6309 Woodsdale Drive. Officers made contact with the residents and further investigation determined that one of them was the driver of the at-fault vehicle. They admitted to the offense and was cited and released.

Vehicle Chase / Fleeing and Eluding / Resisting and Obstructing

An officer attempted to stop a vehicle however, was led on a brief chase before finally coming to a stop. Once the vehicle stopped, the passenger ran from the traffic stop. The driver of the vehicle, a 16-year-old male, was placed under arrest for fleeing and eluding and violation of his GDL. The passenger was later apprehended in the 5300 block of Mocer Ln and resisted officers upon contact. The juvenile driver was arrested, mugged, and turned over to a parent. The passenger was arrested for resisting and obstructing and lodged at the Genesee County Jail.

Accident / Vehicle Pursuit

An officer witnessed a vehicle traveling at a high rate of speed and fail to maneuver the round-a-bout on Dort Hwy causing significant damage. Rather than stop, the vehicle continued driving at a high rate of speed as it entered I75 and travelled to I475 before exiting onto E. Hill Rd. The officer stopped the vehicle as it attempted to re-enter I475. The driver and found to be OWI (.19) and was arrested, processed, and after a datamaster he was lodged at the Genesee County Jail.



COMMUNICATION

TO: Board of Trustee's, Charter Township of Grand Blanc

DATE: May 14, 2021

FROM: Patrick Linihan, Director of Parks & Recreation

SUBJECT: April 2021 Report

Maintenance Staff are busy getting the park ready for the 2021 rental season. Warm days have brought a lot of people out already.

Our tournament schedule has started with a LAX tournament and a Baseball tournament. We will be having tournaments almost all summer this year. AYSO and Detroit City Football Club have started their respective seasons along with Grand Blanc LAX.

Little League has also started, as well with our partnership with LL for the Quad Town Softball League.

Interviewed local High School Students in the Flint Genesee Chambers Summer Youth Initiative program. We were approved for 6 positions and currently have selected 3.

Recreation:

- We had 217 program participants in April
- Mother/Son skate was a successful under the then current restrictions
- Facility rentals are being taken on a daily basis and it is anticipated during the summer season to be booked every weekend.
- Quickly filling up rental spaces
- Interviewing for concessions and programming staff

Maintenance:

- Facilities are being brought back online after winterization.
- Staff have been busy mowing and trimming as the grass starts to take off.
- Soccer goals and LAX goals were assembled and are now in use. Park staff have taken over lining of the fields and the outcome is a very nice product.
- We are currently in the process of working with the engineer for replacement of the pedestrian bridge that failed over the Sherwood Drain. It is anticipated a late fall/winter opening.

Senior Services:

April 2021 Board Report

May 14, 2021

2 of 2

- We had a total of 15 programs with multiple sessions totaling 469 people
- Daily Lunch Program- 582 Lunches Served
- Market Fresh Produce Box- 40 Produce Boxes Distributed
- Monthly Commodities Distribution- 3 Commodities Boxes Distributed
- Medical Loan Closet- 9 Equipment Rentals
- Library Book Pick-Up – Library visits 1
- Medication Pick-Up
- Grocery Order Pick-Up
- Zoom and Facebook Live Exercise Class
- Zoom Support Groups
- Welfare Checks
- Transportation Services – 97 rides
- Veteran Services – 1 appointments
- Legal Services – 10 appointments
- Medicare/Medicaid Counseling: 4 appointments
- COVID-19 Vaccine Registration – 454 registrations
- AARP Tax Appointments - 66 appointments

CHARTER TOWNSHIP OF GRAND BLANC

NOTICE OF TOWNSHIP BOARD MEETING

TUESDAY, May 18, 2021 AT 7:00 P.M.

The Township Board is offering a Hybrid Meeting to keep public contact to a minimum due to Covid-19

To make public comment, please use the Raise Your Hand button located in the bottom right hand corner of the Participant's view. You can also inform the host by using the chat located next to the host's name.

Topic: Township Board Meeting

Time: May 18, 2021 07:00 PM Eastern Time (US and Canada)

Join Zoom Meeting

<https://zoom.us/j/92446867757>

Meeting ID: 924 4686 7757

One tap mobile

+13126266799,,92446867757# US (Chicago)

+16468769923,,92446867757# US (New York)

Dial by your location

+1 312 626 6799 US (Chicago)

+1 646 876 9923 US (New York)

+1 301 715 8592 US (Washington D.C)

+1 669 900 6833 US (San Jose)

+1 253 215 8782 US (Tacoma)

+1 346 248 7799 US (Houston)

+1 408 638 0968 US (San Jose)

Meeting ID: 924 4686 7757

Find your local number: <https://zoom.us/u/acPXhqCrP>

It will be live-streamed on the "Grand Blanc Township" Facebook page.

Posted: May 14, 2021

Dave Robertson

Clerk Dave Robertson