

AUBURN VETERANS MEMORIAL HALL
Meeting Agenda
February 2, 2026 @ 10:00 am
100 East Street, Auburn, CA

Board of Trustees

Charles Peterson
American Legion Post 84

Daniel McLain (Vice President)
American Legion Post 84

John Duenas (President)
VFW Post 904

Chuck Spinks
VFW Post 904

Bonnie B. Potter (Secretary)
Navy League

Donald Anderson
Navy League

Cindy Gustafson
Board of Supervisors

Alternates

Monty Hecker
American Legion Post 84

Gene Freeland
VFW Post 904

Greg Wilbur
Navy League

Sophie Fox
Board of Suoersivors

1. **Call Meeting to Order**
2. **Pledge of Allegiance**
3. **Roll Call**
4. **Approval of Minutes**
 - a. Minutes from December 1, 2025 (Attachment).
5. **Public Comment**
 - a. Any member of the public may address the Hall Board regarding items not on this Agenda. It is requested that comments be brief since the Board is not permitted to take any action on items addressed under public comment. Agenda Items should be submitted at least three (3) weeks in advance for consideration to the Hall Coordinator at AuburnHall@placer.ca.gov.
6. **Information / Non Action Items**
 - a. Work Order / Custodial Hours Report (Attachment).
 - b. Review Preliminary Design Idea for Kitchen Remodel (Attachment).
7. **Action Items**
 - a. Review/Modify/Ratify Building Maintenance Project List (Attachment).
8. **Reports**
 - a. Late-arriving correspondence.
 - b. Veterans Reports.
9. **Announcements**
 - a. Next regularly scheduled meeting date: April 6, 2026
10. **Adjournment**

Placer County is committed to ensuring that persons with disabilities are provided the resources to participate fully in public meetings. If you require disability-related modifications or accommodations, including auxiliary aid or services, to attend or participate in this meeting, please contact Facilities via the below methods. Requests should be made three (3) working days in advance whenever possible. Agenda and Attachments for the above referenced meeting can be viewed at the following link: <http://www.placer.ca.gov/halls>.



Auburn Veterans Memorial Hall Board of Trustees Meeting
December 1, 2025

The meeting was called to order at 5:30 pm by President JD Duenas, who led the Pledge of Allegiance. Present as per sign-in sheet were JD Duenas, VFW Delegate; Chuck Spinks, VFW Delegate; Dan McLain, American Legion Delegate; Charles Peterson, American Legion Delegate; Bonnie Potter, Navy League Delegate; Donald Anderson, Navy League Delegate; Duane Espinoza and Sheryse Lewis of Placer County Facilities Management.

Approval of Minutes: The minutes from October 6, 2025, were distributed and no corrections were noted. Chuck made a motion to approve the minutes as written; second by Don Anderson. Motion carried.

Public Comment: none.

Information/Non-action Items: a). Work Order/Custodial Hours Report was reviewed and discussed. The Fireside room leak was evaluated, and new flashing was installed behind some of the gutters. The items marked for removal in the Fireside room have not yet been removed. Water intrusion issue in the bar is still being evaluated. The plaques for the picture in the upstairs hallway have been mounted. The dumpster key location will be added to the checklist so that renters know where to find it. May need to add a key for upstairs renters. We still need volunteers to work on the artillery pieces. The cross-feed issue with the microphones has been resolved by tuning the system to different channels. May need to add a plate to avoid resetting them. Buckets for used batteries have been placed upstairs and downstairs.

Action Items: a). Building Maintenance Hall Board Project List: Bids are being obtained for kitchen renovations. May have to use in-house labor if no contractor is willing to do the project. Members would like to review the design. No date scheduled as of now. b). Discuss/Consider changing the start time of the meeting to 10:00 am. Chuck made a motion to change the meeting time to 10:00 am beginning with the February meeting; second by Charlie. Motion carried.

Reports: a). Late Arriving Correspondence: none. b). Veterans Reports: VFW: planning a flag retirement in Lincoln on 12/7. American Legion: will be collecting household items for VOA at the December meeting. Navy League: will be collecting for Toys for Tots at the December meeting. Pearl Harbor Remembrance at Solstice Senior Living at 9:55 am on 12/7. Wreaths Across America is 12/13. Army Navy Game watching party at the Hall on 12/13.

Announcements: Next meeting date: February 2, 2026, at 10:00 am.

Adjournment: Meeting was adjourned at 5:57 pm.

Respectfully submitted by Bonnie Potter, Secretary

Date	Request ID	Original Message	Sub Type	Status	Priority	Date Closed	Labor Hours
11/19/2025	204483	Rats are in the kitchen.	Pest Problem	Closed	Low 1-10 Days	11/21/25	
11/19/2025	204488	Hall Board request: Remove items from the fireside room on 2nd floor of Auburn hall. Front right corner has several items to be disposed. The pile has a bench, a couple of hexagon card tables, etc. Everything in that corner goes. Ask Duane for Clarification if needed. Items to be dumped.	Surplus	Closed	Low 1-10 Days	01/06/26	
12/1/2025	161891	CUSTODIAL AUBURN MEMORIAL HALL MMP MMP Maintenance Work	Custodial MMP	Closed	Scheduled 30 Day	12/29/25	54.5
12/11/2025	206113	Replace water heater in kitchen	Project Phase Building Maintenance	In Progress	Continuing		0
12/11/2025	206128	Please inspect around the main entrance on the first floor for a possible window leak.	Roof Leak	Closed	Low 1-10 Days	01/06/26	
12/11/2025	206129	Please clean the windows and blinds throughout the hall. They are incredibly dirty especially the ones you can see when entering the building.	Windows	Closed	Low 1-10 Days	12/22/25	
12/18/2025	206302	Purchase hydration stations.	Drinking Fountain / Hydration Station	Closed	Low 1-10 Days	12/30/25	0
12/31/2025	206650	veteran's report that when medium to heavy rain events occur, water leaks in to their bar area through the sill plate. Please evaluate ways to prevent this intrusion from repeating and repair as needed.	Roof Leak	In Progress	Continuing		
1/1/2026	164142	CUSTODIAL AUBURN MEMORIAL HALL MMP MMP Maintenance Work	Custodial MMP	In Progress	Scheduled 30 Day		26.5
1/7/2026	207952	Men's restroom first floor toilet having issues.	Toilet	Closed	High 1 Day	01/08/26	

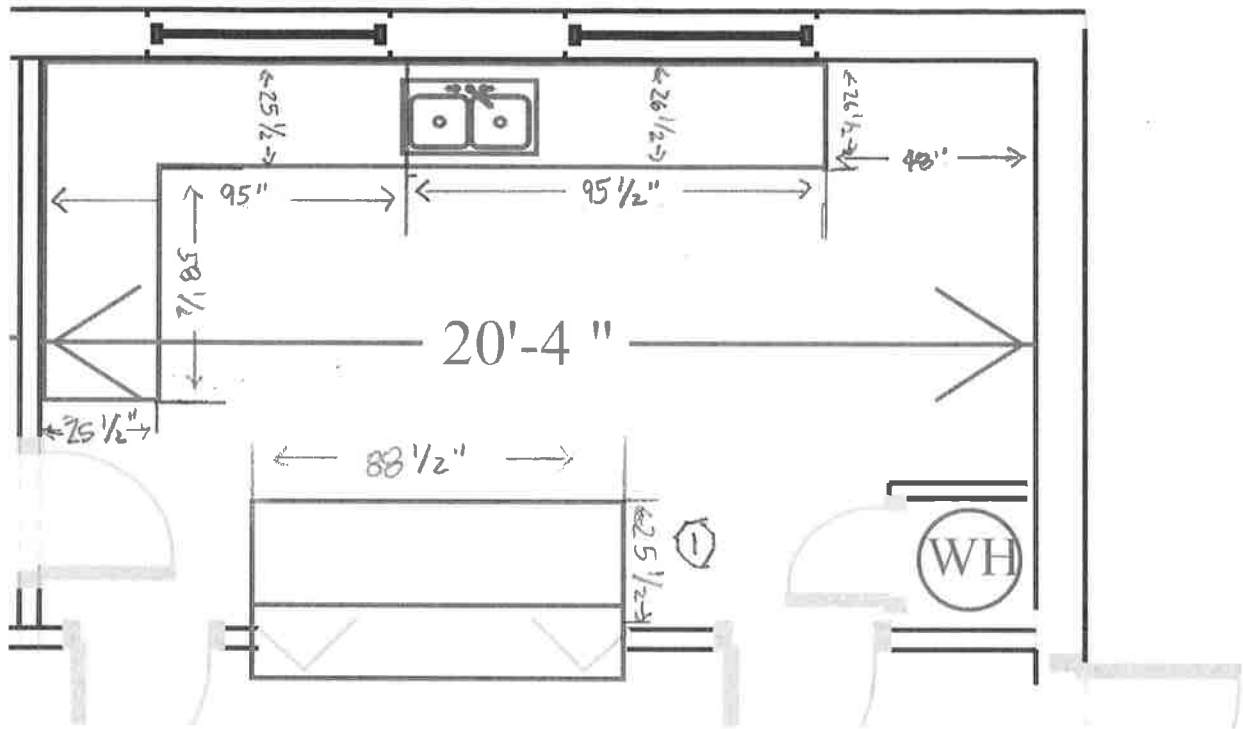

* - ALL COUNTER TOPS ARE APPX 36" H

① - STAND ALONE TABLE w/ WHEELS: 60 5/16" L x 30 1/4" W x 32 1/2" H
and BOTTOM SHELF

Signature

12-10-25
AUBURN MEMORIAL HALL

Allocation Budget Year

(Multiple Items)

Auburn Memorial Hall Allocated Funds

Column Labels
In Progress Planning Grand Total

	In Progress	Planning	Grand Total
PJ01222			
PJ01222 BM GF Memorial Hall Improvements - Auburn			
-	(25,000.00)		(25,000.00)
PJ01222 BM GF Auburn Hall - Kitchen Renovation			
12-17-25 Working with Dan Slifer on equipment measurements to order pieces.		-	-
PJ01222 BM GF Auburn Hall - Replace Auditorium Tables and Carts			
1/14/26 Board decided to defer decision for new tables. This will remain on the project list. Board wants to evaluate the possible Kitchen renovation costs before approving these costs.		4,815.00	4,815.00
Grand Total	(25,000.00)	4,815.00	(20,185.00)