



City of Aberdeen Council Agenda

5:30 p.m. Regular Meeting

February 23, 2026

City Council Chambers

123 South Lincoln Street

Aberdeen, South Dakota 57401

1. Call to Order

- A. Roll Call
- B. Pledge of Allegiance

2. Approval of Agenda

3. Approval of Minutes

- A. City Council Meeting of February 17, 2026

4. Open Forum 5:30 to 5:40 p.m. – 1. See format guidelines at the end of Agenda.

5. Consent Calendar – Possible Approval

- A. Reports and Minutes from City Boards – Receive and place on file:

1. Aberdeen Airport Board Meeting on January 8, 2026
2. KO Lee Library Board Meeting on January 6, 2026
3. Planning Commission Meeting on November 18, 2025
4. Zoning Adjustment Board Meeting January 8, 2026

- B. Day Care Renewal – Carol Eisenbeisz

- C. Set public hearing date on March 23, 2026, at 5:30 p.m. for Ordinance 26-03-01, a petition to rezone certain property located at 903 25th Ave NE

- D. Proclamation: Sandy Sullivan Day - February 28

- *Council members may abstain regarding an identified item in the consent calendar and vote to approve the remainder of the items.*

6. Old Business

- A. Possible second reading and final adoption of Ordinance No. 26-02-01 amending the landscape regulations to permit artificial turf

- B. Possible second reading and final adoption of Ordinance No. 26-02-11 regarding private ambulance services
- C. Possible second reading and final adoption of Ordinance No. 26-02-09 approving sewer system improvements and authorizing issuance of a Clean Water SRF revenue bond
- D. Possible second reading and final adoption of Ordinance No. 26-02-10 establishing a sewer surcharge for CW-05 SRF debt service

7. **New Business**

- A. Public Hearing on a request for a Special One-Day, On-Sale, Liquor License for Boys & Girls Club of Aberdeen, Winefest 2026, March 28, 2026, 1123 N Lincoln St
- B. Public Hearing and possible approval of the transfer of Retail On-Off Sale Malt Beverage and SD Farm Wine License RB-27440 from Walar Inc. dba Palm Garden Thai Cuisine, 602 S 3rd St to Myint Tun Aung dba Palm Garden Thai Cuisine, 602 S 3rd St
- C. Possible first reading and passage of Resolution No. 26-02-02R accepting dedication of certain public improvements in Dakota Estates Subdivision
- D. Public hearing and possible approval of the first reading of Ordinance 26-02-03, a petition to rezone from R-3 to M, Property at 3304 Harrison Street N, legally described as Lot 7, Block 6, HAPI Second North Aberdeen Subdivision to the City of Aberdeen, in the NW¼ of Section 6-Township 123 North-Range 63 West of the 5th P.M., Brown County, South Dakota
- E. Public hearing and possible approval of the first reading of Ordinance 26-02-04, a petition to rezone from R-2 to M, Property at 2006 Lawson Street S, legally described as Lot 2, Second Replat of Southaven First Addition to the City of Aberdeen, in the NW¼ of Section 30-Township 123 North-Range 63 West of the 5th P.M., Brown County, South Dakota
- F. Public hearing and possible approval of the first reading of Ordinance 26-02-05, a petition to rezone from I-1 to M, Property at 4406 Eighth Avenue NE, legally described as Lot 1, NE Water Tower Addition to the City of Aberdeen, in the NE¼ of the NW¼ of Section 16-Township 123 North-Range 63 West of the 5th P.M., Brown County, South Dakota
- G. Permission to install supergraphic signs in a (C-3) Central Business Zoning District
- H. Possible authorization for City Manager to sign consent form for South Dakota Department of Agriculture and Natural Resources (DANR) Brownfields Grant assessment of certain city-owned facilities
- I. Possible approval of 2026 Seal Coat Aggregates
- J. Possible approval of 2026 Asphaltic Concrete and Surfacing Repair Mix Bid

- K. Possible approval of 2026 Road Oil Bid
- L. Possible approval of bid by CWF Concrete & Masonry of Aberdeen, SD in the amount of \$139,057.80 for project CONC-2026-1 (Annual Concrete Work)
- M. Possible approval of bid by CWF Concrete & Masonry of Aberdeen, SD in the amount of \$171,922.28 for project CONC-2026-2 (Accessible Sidewalk Quadrant Improvements)
- N. Possible approval of bid by Wright & Sudlow Inc. of Aberdeen, SD in the amount of \$238,351.00 for project CONC-2026-3 (Street Maintenance Concrete Repair 1)
- O. Possible approval of Recommendation on Bids for the Water Treatment Plant Pipe Gallery Valve Replacement Project
- P. Possible approval of bid by Reede Construction Inc. of Aberdeen, SD in the amount of \$2,636,134.75 for project ST-2026-2 (North Dakota Street Reconstruction)

8. Review and Approval of Claims and Payroll

- A. Bills: approval of bill list for February 23, 2026
- B. Payroll: approval for pay period from February 8, 2026, through February 21, 2026, and city's share of social security, old age, and survivor's insurance, retirement, health, and life insurance
 - *Council members may abstain regarding an identified claim in the bill list or payroll and vote to approve the remainder of the bills or payroll*

9. City Manager's Report

10. Adjournment

- **Open Forum:** Open forum provides an opportunity for the public to address the city council with questions, concerns, or comments on items which are not on the agenda. Citizens are asked to sign up to speak prior to the open forum portion of the meeting. The open forum will be limited to ten (10) minutes. If no one is in attendance for the open forum, the regular meeting may begin, unless a majority of the city council agrees to extend the time period. The open forum may not be used to make personal attacks, to air personal grievances, to make political endorsements, or for political campaign purposes. The open forum will not be used as a time for problem solving or reacting to the comments made, but rather for hearing the citizen for informational purposes. The city council may respond with a request for city staff to follow up and report back on any issue raised during the public address time. A presentation may not exceed three minutes in duration.
- **ADA Compliance:** The City of Aberdeen fully subscribes to the provisions of the Americans with Disabilities Act. If you desire to attend this public meeting and are in need of special accommodation(s), please notify the City Finance Office at least eight (8) hours prior to the meeting so appropriate auxiliary aids and services can be made available. The regular scheduled City Council Meetings are held on the first, third, and fourth Monday of each month at 5:30 p.m. except when a holiday falls on Monday, in which case the meeting is held at 5:30 p.m. on the next business day.
- **Agenda Packet:** A copy of the subject matter on the city council meeting agenda is available for public distribution at the City Finance Office and available on the city's website at www.aberdeen.sd.us.

MINUTES

ABERDEEN CITY COUNCIL MEETING

City Council Chambers, 123 South Lincoln Street, Municipal Building, Aberdeen, South Dakota, February 17, 2026, at 5:30 p.m., regular meeting of the City Council.

CALL TO ORDER

MEETING ROLL CALL

Present at roll call were City Council Members Rob Ronayne, Erin Fouberg, Charlotte Liebelt, Rich Ward, Alan Johnson, Talmage Ekanger, Chad Nilson, David Novstrup, and Mayor Travis Schaunaman.

City Staff present were Dave McNeil, Ron Wager, Stuart Nelson, Ken Hubbard, Joel Weig, Tanner Jondahl, Destin Spellman, Matt Braun, Aaron Kiesz, Amanda Fischer, Cara Perrion, Amber Schwab, Emily Ellingson, Steve Thithavong, and Jordan McQuillen.

PLEDGE OF ALLEGIANCE

Mayor Schaunaman led the Pledge of Allegiance.

APPROVAL OF AGENDA

Motion by Ekanger, second by Ward, to approve the agenda. Voice vote to approve, all present voting aye, motion carried.

MINUTES

Motion by Liebelt, second by Novstrup, to approve the minutes of the February 2, 2026, City Council Meeting, as circulated and Payroll Section of City Council Meeting Minutes of February 2, 2026, as amended: EFTPS 187,150.76, SD Retirement System 115,726.64, City Health Insurance 103,657.50, Governing Body Council 3,921.89, City Manager 10,860.60, Attorney 8,932.14, Finance Office 19,580.59, Human Resources 11,972.22, Municipal Hall 2,315.35, Computer Services 6,786.78, Community Development 19,099.20, Engineering 15,888.65, Police 194,762.90, Timothy Morgan 32.73/hr, Fire 186,545.26, Gregory Lux 21.58/hr, Jaiden Bunn 21.58/hr, Thomas Miller 21.58/hr, Nikolas Pezonella 21.58/hr, Building Inspection 8,296.00, Street 49,287.20, Traffic Control 9,920.33, Utilities - General 37,992.43, Robb Erickson 20.00/hr, Solid Waste 31,214.87, Wastewater Treatment 27,276.47, Utilities - Sewer 10,911.02, Water Treatment Plant 28,042.92, Richard Martin 30.19/hr, Utilities - Water 2,629.79, Airport 28,191.34, Dylan LaFollette 24.78/hr, Cemetery 4,869.75, Transit 32,383.42, Meals on Wheels 825.35, Admin 11,122.14, Participant Rec 16,899.22, Park Rec ARCC 30,213.24, Park Rec Golf

1 7,394.70, PC Complex 8,648.91, Park Rec Senior Center 7,150.23, Parks 22,070.06, Parks/Wylie
2 12,581.27, Forestry 12,352.05, Library 34,927.52, City Economic Development 3,169.60. Voice
3 vote to approve, all present voting aye, motion carried.

4 **OPEN FORUM**

5 No one appeared in open forum to address the Council.

6 **CONSENT CALENDAR**

7 Motion by Nilson, second by Ward, to approve the following items on the consent calendar:

8 COMMUNITY EVENT PERMIT – HUGS Mental Mile on June 20, 2026

9 POSSIBLE APPROVAL OF ARPA REIMBURSEMENT REQUEST NO. 7 seeking
10 reimbursement for contracting fees in the amount of \$1,908,172.76

11 POSSIBLE APPROVAL OF SRF LOAN REIMBURSEMENT REQUEST NO. 8 seeking
12 reimbursement for engineering services in the amount of \$57,991

13 LOTTERY NOTICE – receive and place on file: Aberdeen Area Humane Society

14 SET PUBLIC HEARING DATE ON FEBRUARY 23, 2026, for the Transfer of Retail On-
15 Off Sale Malt Beverage and SD Farm Wine License RB-27440 from Walar Inc. dba Palm Garden
16 Thai Cuisine, 602 S 3rd St to Myint Tun Aung dba Palm Garden Thai Cuisine, 602 S 3rd St

17 DAY CARE LICENSE RENEWAL: Kaitlyn Kassube

18 SET BID DATE ON MARCH 17, 2026, at 2:00 P.M. for the Aberdeen Public Works
19 Maintenance Building

20 Voice vote to approve, with Council Member Nilson abstaining to items B and C, all
21 present voting aye, motion carried.

22 **NEW BUSINESS**

23 DAY CARE UPDATE

24 Economic Development Director and Public Information Officer Schwab, Community
25 Development Administrative Assistant Ellingson, and Finance Office Compliance and Records
26 Specialist Thithavong presented day care updates.

27 FIRST READING OF ORDINANCE NO. 26-02-01 AMENDING THE LANDSCAPE
28 REGULATIONS TO PERMIT ARTIFICIAL TURF

29 City Attorney Wager presented the first reading of Ordinance No. 26-02-01. Motion by
30 Ward, second by Foubert, to approve the first reading of Ordinance No. 26-02-01 amending the
31 landscape regulations to permit artificial turf. Roll call vote to approve, all present voting aye,

1 motion carried.

2 FIRST READING AND PASSAGE OF RESOLUTION NO. 26-02-01R OF INTENT TO
3 LEASE APPROXIMATELY 475 ACRES OF CITY-OWNED LAND TO PRIVATE PERSONS
4 FOR 5-YEAR GRASS LAND LEASES BEGINNING IN 2026

5 City Attorney Wager presented Resolution No. 26-02-01R. Motion by Ronayne, second by
6 Nilson, to approve the first reading and passage of Resolution No. 26-02-01R of intent to lease
7 approximately 475 acres of city-owned land to private persons for 5-year grass land leases
8 beginning in 2026. Roll call vote to approve, all present voting aye, motion carried.

9 FIRST READING OF ORDINANCE NO. 26-02-11 REGARDING PRIVATE
10 AMBULANCE SERVICES

11 City Manager McNeil and City Attorney Wager presented Ordinance No. 26-02-11.
12 Motion by Ward, second by Ronayne, to approve the first reading of Ordinance No. 26-02-11
13 regarding private ambulance services. Roll call vote to approve, all present voting aye, motion
14 carried.

15 APPROVAL OF FIRST READING OF ORDINANCE NO. 26-02-09 APPROVING
16 SEWER SYSTEM IMPROVEMENTS AND AUTHORIZING ISSUANCE OF A CLEAN
17 WATER SRF REVENUE BOND

18 Finance Officer McQuillen presented Ordinance No. 26-02-09. Motion by Ronayne,
19 second by Ward, to approve the first Reading of Ordinance No. 26-02-09 approving sewer system
20 improvements and authorizing issuance of a Clean Water SRF revenue bond. Roll call vote to
21 approve, all present voting aye, motion carried.

22 APPROVAL OF FIRST READING OF ORDINANCE NO. 26-02-10 ESTABLISHING
23 A SEWER SURCHARGE FOR CW-05 SRF DEBT SERVICE

24 Finance Officer McQuillen presented Ordinance No. 26-02-10. Motion by Ekanger, second
25 by Nilson, to approve the first reading of Ordinance No. 26-02-10 establishing a sewer surcharge
26 for CW-05 SRF debt service. Roll call vote to approve, all present voting aye, motion carried.

27 ABATEMENT OF PROPERTY TAXES FOR REAL PROPERTY WITHIN CITY
28 LIMITS

29 Finance Officer McQuillen presented the abatements. Motion by Liebelt, second by
30 Novstrup, to approve the abatement of property taxes for real property within city limits. Roll call
31 vote to approve, with Council Member Ward abstaining, all others present voting aye, motion

1 carried.

2 APPROVAL OF WRF IMPROVEMENTS PAY REQUEST NO. 8 IN THE AMOUNT
3 OF \$1,908,172.76 TO PKG CONTRACTING INC.

4 Water Reclamation Superintendent Fischer presented the pay request. Motion by Ronayne,
5 second by Ekanger, to approve the WRF Improvements Pay Request No. 8 in the amount of
6 \$1,908,172.76 to PKG Contracting Inc. Roll call vote to approve, with Council Member Nilson
7 abstaining, all others present voting aye, motion carried.

8 APPROVAL TO AUTHORIZE THE PURCHASE OF A NEW 2026 CHEVROLET
9 SILVERADO TRUCK, 1 TON 4X4 SHORT BOX, CREW CAB, FROM LAMB CHEVROLET
10 OF ONIDA (VENDOR #: 12037702, CONTRACT #: 17965) USING THE SOURCEWELL
11 CONTRACT # 17965-20BC

12 City Engineer Nelson presented the purchase request. Motion by Johnson, second by Ward,
13 to approve and authorize the purchase of a new 2026 Chevrolet Silverado truck, 1 ton 4X4 short
14 box, crew cab, from Lamb Chevrolet of Onida (Vendor #: 12037702, CONTRACT #: 17965)
15 using the SourceWell Contract # 17965-20BC. Roll call vote to approve, all present voting aye,
16 motion carried.

17 APPROVAL OF THE PURCHASE OF A HORTON TYPE III AMBULANCE FROM
18 PREMIER SPECIALTY VEHICLES OF FERGUS FALLS, MN, IN THE AMOUNT OF
19 \$301,644.00 THROUGH THE SAVVIK BUYING GROUP

20 Fire Chief Weig presented the purchase request. Motion by Ronayne, second by Ekanger,
21 to approve the purchase of a Horton Type III ambulance from Premier Specialty Vehicles of Fergus
22 Falls, MN, in the amount of \$301,644.00 through the SAVVIK buying group. Roll call vote to
23 approve, all present voting aye, motion carried.

24 APPROVAL OF PAY REQUEST #4 FOR WT-2025-1 (WATER TOWER AND
25 TRANSMISSION LINE) IN THE AMOUNT \$385,961.66 TO DAHME CONSTRUCTION INC.
26 OF ABERDEEN, SD FOR SCHEDULE A AND \$888,938.75 TO LANDMARK STRUCTURES
27 INC. OF FORT WORTH, TX FOR SCHEDULE B

28 Assistant City Engineer Spellman presented the pay request. Motion by Ward, second by
29 Johnson, to approve Pay Request #4 for WT-2025-1 (Water Tower and Transmission Line) in the
30 amount \$385,961.66 to Dahme Construction Inc. of Aberdeen, SD for Schedule A and
31 \$888,938.75 to Landmark Structures Inc. of Fort Worth, TX for Schedule B. Roll call vote to

1 approve, all present voting aye, motion carried.

2 APPROVAL OF BID BY JENSEN ROCK & SAND, INC. OF MOBRIDGE, SD IN THE
3 AMOUNT OF \$440,123.59 FOR PROJECT ST-2026-1 (10TH AVE SE/ GOODRICH AVE SE
4 MILL & OVERLAY IMPROVEMENTS

5 Assistant City Engineer Spellman presented the bid. Motion by Johnson, second by Nilson,
6 to approve the bid by Jensen Rock & Sand, Inc. of Mobridge, SD in the amount of \$440,123.59
7 for project ST-2026-1 (10th Ave SE/ Goodrich Ave SE Mill & Overlay Improvements. Roll call
8 vote to approve, all present voting aye, motion carried.

9 APPROVAL OF RECOMMENDATION ON BIDS FOR THE WATER TREATMENT
10 PLANT PIPE GALLERY DECKING PROJECT

11 City Engineer Nelson presented the recommendations on bids. Motion by Ward, second by
12 Liebelt, to approve the Recommendation on Bids for the Water Treatment Plant Pipe Gallery
13 Decking Project. Roll call vote to approve, all present voting aye, motion carried.

14 APPROVAL OF THE PARK & RECREATION BOARD NAMING A NEW PARK AND
15 FULL-SIZE DOLL HOUSE

16 Parks, Recreation & Forestry Director Braun presented the naming a new park and full-
17 size doll house. Motion by Liebelt, second by Johnson, to approve the Aberdeen Park & Recreation
18 Board naming of the new full-size doll house structure in Storybook Land as the “The Cindy
19 Haglund Doll House” as set forth in the “Donation Acknowledgment and Naming Rights
20 Agreement” dated 10-27-25 and the Aberdeen Park & Recreation Board naming of the new park
21 located in HAPI Central subdivision on Lot 2 of 2nd Replat of Southaven First Addition, in the
22 NW¼ of Section 30, Township 123 North, Range 63 West of the 5th P.M., Brown County, South
23 Dakota, as the “Good News Park”. Voice vote to approve, all present voting aye, motion carried.

24 APPROVAL OF PAYMENT AND CHANGE ORDER FOR AIP/AIG PROJECT #3-46-
25 0001-53/54-2025 AIRPORT TERMINAL ACCESS ROAD AND TERMINAL PARKING LOT
26 FOR THE FOLLOWING: 1. INVOICE #11 TO HELMS & ASSOCIATES FOR
27 CONSTRUCTION ADMINISTRATION AND RESIDENT ENGINEERING SERVICES IN
28 THE AMOUNT OF \$2,600.37, 2. PAY ESTIMATE #5 TO DAHME CONSTRUCTION FOR
29 WORK COMPLETED IN THE AMOUNT OF \$6,399.91, 3. CHANGE ORDER #2 (FINAL) TO
30 DAHME CONSTRUCTION A DECREASE OF \$177,133.06 IN CONTRACT AMOUNT

31 Council Member Johnson presented the pay requests on behalf of Transportation Director

1 Krokkel. Motion by Ward, second by Fouberg, to approve payment and change order for AIP/AIG
 2 Project #3-46-0001-53/54-2025 Airport Terminal Access Road and Terminal Parking Lot for the
 3 following: 1. Invoice #11 to Helms & Associates for Construction Administration and Resident
 4 Engineering Services in the amount of \$2,600.37, 2. Pay estimate #5 to Dahme Construction for
 5 work completed in the amount of \$6,399.91, 3. Change Order #2 (Final) to Dahme Construction a
 6 decrease of \$177,133.06 in contract amount. Roll call vote to approve, all present voting aye,
 7 motion carried.

8 APPROVAL OF PAY REQUEST TO HELMS & ASSOCIATES FOR THE
 9 FOLLOWING: 1. INVOICE #26 IN THE AMOUNT OF \$4,176.16 AND AUTHORIZE CITY
 10 MANAGER TO SIGN INVOICE FOR AIP PROJECT #3-46-0001-52-2024 GA APRON
 11 RECONSTRUCTION, PHASE 2, 2. INVOICE #11 IN THE AMOUNT OF \$724.35 AND
 12 AUTHORIZE CITY MANAGER TO SIGN INVOICE FOR AIP PROJECT #3-46-0001-55/56-
 13 2025 AIRPORT TERMINAL EXPANSION, 3. INVOICE #6 IN THE AMOUNT OF \$905 AND
 14 AUTHORIZE CITY MANAGER TO SIGN INVOICE FOR AIP PROJECT #3-46-0001-57-2025
 15 PRE-CONDITIONED AIR (PCA) UNIT, 4. INVOICE #2 IN THE AMOUNT OF \$5,600.22 AND
 16 AUTHORIZE CITY MANAGER TO SIGN INVOICE FOR AIP PROJECT #3-46-0001-58-2026
 17 SRE BUILDING EXPANSION

18 Council Member Johnson presented the pay requests on behalf of Transportation Director
 19 Krokkel. Motion by Ekanger, second by Novstrup, to approve pay request to Helms & Associates
 20 for the following: 1. Invoice #26 in the amount of \$4,176.16 and authorize City Manager to sign
 21 invoice for AIP Project #3-46-0001-52-2024 GA Apron Reconstruction, Phase 2, 2. Invoice #11
 22 in the amount of \$724.35 and authorize City Manager to sign invoice for AIP Project #3-46-0001-
 23 55/56-2025 Airport Terminal Expansion, 3. Invoice #6 in the amount of \$905 and authorize City
 24 Manager to sign invoice for AIP Project #3-46-0001-57-2025 Pre-Conditioned Air (PCA) Unit, 4.
 25 Invoice #2 in the amount of \$5,600.22 and authorize City Manager to sign invoice for AIP Project
 26 #3-46-0001-58-2026 SRE Building Expansion. Roll call vote to approve, all present voting aye,
 27 motion carried.

28 **REVIEW AND APPROVAL OF CLAIMS AND PAYROLL**

29 Motion by Liebelt, second by Ekanger, to approve payment of the bills listed for February
 30 17, 2026.

31 Bills having been audited by the Finance Officer and fully itemized and authorize the

1 Mayor or City Manager to sign, and the Finance Officer to countersign, all warrants for payment
2 of the following approved bills: Century Link 5,000.00, US Bank Corp Trust 17,334.95, Wellmark
3 BCBS of SD 248,000.00, SD Dept. of Revenue 11,231.08, Utility 446.63: Pantorium Cleaners
4 44.41, Jose Epp 49.43, Max Vega 50.96, Jay Street Properties 57.65, Nicholas Penix 16.38, Charlie
5 Tveit 64.57, Angela Hughes 15.42, Eddie Falcon 18.28, Carlsen Funeral Home 67.68, A&A
6 Property Mgmt. 61.85, A-1 Sanitation & Recycling LLC 11,713.69, Abdn Area Human Resource
7 Assn. 275.00, Abdn Area Humane Society 6,400.00, Abdn Downtown Assoc. 27,500.00,
8 Aberdeen Aqua Addicts 10,000.00, Aberdeen Chamber of Commerce 850.00, Aberdeen Chrysler
9 Center 1,847.00, Aberdeen Family YMCA 50,000.00, Aberdeen Hockey Assn. 28,162.00,
10 Aberdeen Insider 815.83, Aberdeen Truck & Trailer 15.42, Allied Climate Professionals 5,385.27,
11 Amber Dallmann 50.00, Amber Hanson 168.75, Amy Lebeau 112.50, Andrea Heupel 98.57,
12 Andrew Rohrbach 260.00, Aqua Pure Inc. 350.00, AT&T Cell 665.56, Auto Value - Aberdeen
13 2,542.24, Automatic Building Controls 2,634.00, AutoZone 1,192.51, B & B Contracting
14 12,755.13, Badger Meter Inc. 2,224.89, BMI 459.00, BNSF Railway Co. 2,356.10, Borns Group
15 2,460.00, Bound Tree Medical LLC 2,345.53, Brock Degroot 130.00, Brooks Gilbert 494.00,
16 Brown County Landfill 23,023.30, Brown County Treasurer 28.70, Buller Fixture Company
17 18,955.55, Butler Machinery Co. 6,602.73, ByteSpeed LLC 3,885.00, Caden Sharping 363.02,
18 CardConnect LLC 325.00, Cassandra Schumacher 318.00, Cellebrite Inc. 11,628.00, Center Point
19 Large Print 273.27, Century Business Products 1,237.94, CenturyLink 85.28, Chelsee Shortt
20 96.00, Chelsey Albrecht 136.00, Chris Scott 280.00, City Treasurer 41.76, Clayton Innis 140.00,
21 Cole Bergan 78.00, Cole Papers Inc. 11,462.13, Connections Inc. EAP 610.60, Convention
22 Visitors Bureau 74,604.76, Cooper Animal Clinic P.C. 269.00, Crawford Trucks & Equip.
23 1,300.00, Crescent Electric Supply 6,141.29, Custom Installation Solutions 607.00, D&O
24 Trucking LLC 470.00, Dacotah Paper Co. 79.90, Dahme Construction 392,361.57, Dakota
25 Broadcasting LLC 500.00, Dakota Custom Turf 4,746.24, Dakota Doors Incorporated 317.80,
26 Dakota Fluid Power Inc. 2,504.01, Dakota Oil 1,040.90, Dakota Supply Group 2,098.39, Daniel
27 Orr 230.00, David's Lawn & Snow 170.00, Dawn Menning 131.25, Dependable Sanitation
28 33,474.76, Diesel Machinery Inc. 87.57, Direct Automation LLC 705.00, District IV EMS 285.00,
29 Ditch Witch UnderCon 1,564.40, DiVal Safety Equipment Inc. 798.66, DLT Solutions Inc.
30 6,497.92, Dockendorf Equip. Co. Inc. 1,464.32, Domino's Pizza 217.02, Don's Builders Hardware
31 152.50, DuBois Chemicals Inc. 20,524.17, Eframson Electric Inc. 418.62, eFurnitureMax LLC

1 6,040.06, Emblem Enterprises Inc. 751.39, Entenmann-Rovin Co. 275.50, eRange Inc. 400.00,
2 Farm Power Mfg. Inc. 30,606.82, Fastenal Company 63.89, Fay's Refrigeration LLC 1,299.53,
3 Federal Express Corp. 19.99, Fire Safety First 3,436.18, FLSmidth Krebs Inc. 482.86, Frontier
4 Precision Inc. 5,750.00, G & R Controls Inc. 14,374.00, Galls Inc. 140.75, Geffdog Designs
5 13,406.63, Gelling's Auto Service 147.49, Graham Tire Co. 683.23, Grainger 2,832.58, Graymont
6 (WI) LLC 6,852.93, Greg Webb 265.30, Grote Sheet Metal Inc. 1,232.00, Haar Plumbing &
7 Heating Inc. 107.14, Haas Creative 625.00, Hardy Rosarians of SD 535.34, Harms Heating and
8 Cooling Inc. 255.10, Harms Oil Company 21,426.14, Harves Sport Shop 6,559.21, Hawkins Inc.
9 9,244.20, Helms & Associates 47,397.17, Henry Schein Inc. 2,277.84, Hillyard Sioux Falls
10 145.31, House of Glass Inc. 4,522.15, Hub City Radio 1,616.00, IAPE 65.00, IDEXX Distribution
11 Inc. 2,617.14, Impact Janitorial 3,640.25, Ingram Library Services 8,355.65, Innovative Interfaces
12 Inc. 3,272.36, Interstate Battery Arlington 599.80, IP Media Holdings Inc. 1,130.00, Jackie
13 Witlock 114.17, Jackson Lewis P.C. 22,307.06, James Valley Coop Telephone Co. 35.26, JanWay
14 Company USA Inc. 233.00, Jarman's Water Systems 844.22, Jensen Rock & Sand Inc.-Moberge
15 1,628.05, JGE Inc. 34,751.26, Joel Weig 280.00, Johnson Feed Inc. 18,001.64, Jonah Stolp 245.30,
16 Jonathon Murdy 4,166.00, Jordan Menken 189.00, Joseph Berns 150.00, Joshua Steinwandt
17 156.00, Kannon Coats 60.00, Katrina Holzkamm 136.00, Ken's Superfair Foods 71.94, Kessler's
18 80.30, Kirk's Auto 11,076.44, Korterra Inc. 5,736.64, Ladner Electric 356.34, Landmark Structures
19 I LP. 888,938.75, Language Line Services 757.79, Lawrence Diggs 22.50, Leidholt Electric LLC
20 149.56, Linde Gas & Equip. Inc. 499.98, Linde Inc. 14,304.52, Livestock Specialist Inc. 2,531.54,
21 Luke Nelson 350.00, Lund Industries 1,799.62, Lyla Agius 306.00, Lynn Gauer 180.00,
22 MacQueen Emergency Group 428.59, Mac's Inc. 291.11, Marco Technologies LLC 778.43, Marsh
23 & McLennan Agency LLC 12,420.00, Marshall County Sportsman Club 300.00, Marshall-Bond
24 Pumps Inc. 1,246.26, Matheson Tri-Gas Inc. 847.44, Max Stoltenburg 20.00, M-B Companies Inc.
25 312.36, McQuillen Creative Group Inc. 2,929.75, Menards Inc. 4,809.57, Metering & Technology
26 Solutions 9,480.36, Michael Bartz 252.00, Michael Frederick 50.00, Michael J. Burns Architects
27 Ltd. 2,518.33, Midcontinent Communications 2,382.24, Midstates Group 12,436.91, Midwest
28 Alarm Company 358.23, Midwest Tape 3,533.54, Mitchell Public Library 25.00, Moody's Investor
29 Services 33,000.00, MTI Distributing 14,873.63, NAPA Central 290.00, National EMS
30 Management Assn. 14,000.00, Nelson Sales & Service LLC 167.92, Nextiva Inc. 7,798.65, Nicole
31 Volk 100.00, North Central Rental/Leasing 7,932.00, North Central Weed & Pest Control 822.72,

1 Northern Plains Animal Health 248.92, Northern Valley Communications 1,031.37, Northstock
 2 Inc. 1,125.61, NSU Workstudy 151.88, ODP Business Solutions LLC 309.36, One Source 492.10,
 3 O'Reilly Auto Parts 147.86, OverDrive Inc. 6,959.84, Patriot Fire & Safety Inc. 17,216.78,
 4 Performance Oil & Lubricants 5,173.42, Pierson Ford-Lincoln-Mercury 16,298.10, PKG
 5 Contracting Inc. 1,908,172.76, Plunkett's Pest Control 372.66, Pomp's Tire Service 1,862.24, Quill
 6 Corporation 178.86, R & R Products Inc. 1,726.55, Randy Murphy 147.00, RBL Designs 300.00,
 7 RDO Equipment Co. 617.90, Rick's Heating & Air Conditioning Inc. 112.25, Runnings Supply
 8 Inc. #14 3,224.61, Safety Service Inc. 321.50, Sanford Health 750.00, Sanford Health
 9 Occupational 3,307.00, Sanitation Products Inc. 2,291.73, Schwan Welding & Boiler 70.00, SD
 10 Dept. of Public Safety 2,590.00, SD Dept. of Transportation 1,620.28, SDSU Extension 210.00,
 11 Shannon Broderson 63.00, Share Corp. 3,537.06, Sherwin-Williams Co. 114.70, Sound Decisions
 12 162.96, South Dakota One Call 55.65, Stan Houston Equipment Inc. 706.21, Staples 427.78, Stern
 13 Oil Company Inc. 2,746.00, Steve Markley 156.00, Steven Lust Automotive 165.17, Sunbelt
 14 Rentals Inc. 3,402.76, Swanson Flo-Systems Co. 944.11, The Library Store 256.55, Thomson
 15 Reuters 127.74, Tim Reed 549.00, Timothy J. Aho 4,466.00, T-Mobile USA Inc. 2,488.80,
 16 Transource Truck & Equipment 591.13, TripleC Pros Window Cleaning 550.00, Tri-State Water
 17 Inc. 127.25, Trumpet Inc. 435.60, Ty Sieber 40.00, Tyler Technologies 3,770.00, Tyson Paulson
 18 100.00, Ultimate Graphics 884.00, Uniform Center 123.19, Vermont Systems Inc. 25,293.19,
 19 Vestis Group Inc. 2,910.51, Vollan Oil Co. 6,816.50, WEB Water Development Assn. 2,346.00,
 20 Western Area Power Adm. 6,789.23, Western States Fire Protection 6,753.90. Roll call vote to
 21 approve, with Council Member Ward abstaining, and Nilson abstaining payment to PKG
 22 Contracting Inc., all others present voting aye.

23 **CITY MANAGER'S REPORT**

24 City Manager McNeil introduced Cara Perrion as the new library director, recapped the
 25 Washington D.C. trip, and announced employee milestones.

26 **EXECUTIVE SESSION**

27 Motion by Nilson, second by Ward, to move into executive session to discuss personnel,
 28 legal, and contractual matters pursuant to SDCL §1-25-2(1)(3) and (4). Voice vote to approve, all
 29 present voting aye, motion carried. The Council moved into executive session at 6:50 p.m.

30 Motion by Nilson, second by Johnson, to end executive session and return to opening
 31 meeting. Voice vote to approve, all present voting aye, motion carried. The Council returned to

1 open meeting at 7:59 p.m.

2 **ADJOURNMENT**

3 There being no further business, motion by Johnson, second by Ekanger, to adjourn the
4 meeting. Voice vote to adjourn, all present voting aye, motion carried. The meeting adjourned at
5 7:59 p.m.

6 Prepared by Steve Thithavong for the Finance Office. /s/Jordan McQuillen, Finance Officer

City Of Aberdeen – Request for Council Action February 23, 2026

Agenda Section – Consent Calendar

This request for council action lists all the items which have been included in the consent agenda for this meeting. The city council can approve all of the items with a single motion to approve. The mayor will allow the council members an opportunity to state whether there are any of these items which you wish to have removed from the consent agenda approval and to have discussed and acted upon separately by the city council.

Items:

- A. Reports and Minutes from City Boards – Receive and place on file:
 - 1. Aberdeen Airport Board Meeting on January 8, 2026
 - 2. KO Lee Library Board Meeting on January 6, 2026
 - 3. Planning Commission Meeting on November 18, 2025
 - 4. Zoning Adjustment Board Meeting January 8, 2026
- B. Day Care Renewal – Carol Eisenbeisz
- C. Set public hearing date on March 23, 2026, at 5:30 p.m. for Ordinance 26-03-01, a petition to rezone certain property located at 903 25th Ave NE
- D. Proclamation: Sandy Sullivan Day - February 28

**MINUTES
ABERDEEN AIRPORT BOARD
Regular Meeting
January 8, 2026**

MEMBERS PRESENT: Tony Schwan, Michael Erickson, Jarrett Rix

MEMBERS ABSENT: Lon Gellhaus

OTHER PRESENT: Airport Staff: Rich Krokkel, Marvin Black, Rhea Ketterling; COA: Dave McMeil (City Manager), Alan Johnson (City Councilor); Kyler Dinger (BC Commissioner); Michael Schmit (Helms & Associates), Mark Caven (Aberdeen Flying Service), Scott Waltman (Aberdeen Insider)

Chair Schwan called the regular monthly scheduled meeting of the Aberdeen Airport Board to order at 10:30AM on Thursday, January 8th, 2026.

Item #2 Approval of Minutes from December 4th, 2025, Meeting – Moved by Rix, seconded by Erickson. **MOTION CARRIED.**

Item #3 Adoption of the Agenda – Moved by Erickson, seconded by Rix. **MOTION CARRIED.**

Item #4 Next Meeting – Thursday, February 5th

Old Business:

New Business:

Item #5 December Bills – The cameras are an addition to the current system and is a budgeted item. Other big items mentioned are the roll-up door for the security checkpoint, wet service for the MB equipment, fuel, liquid and solid for snow and ice control. Budget for snow removal is on target. Moved by Erickson, seconded by Rix. **MOTION CARRIED.**

Item #6 December Financial Report – Moved by Rix, seconded by Erickson. **MOTION CARRIED.**

Item #7 Recommend approval to Advertise for Bids for Hay Grass Land Leases – The Board received a copy of the advertisement along with the map of the grass land tracts. Airport hay land is bid out every five years. The only change this time is that tract R is now a full production tract. This was previously bid as a low productivity land as it was used for an asphalt plant. We then re-seeded in 2021. The farmer who had this tract harvested as many bales off this land as he ever had. Erickson asked if we had any problems with farmers getting the bales off property. Krokkel stated we did not. Moved by Erickson, seconded by Rix. **MOTION CARRIED.**

Item #8 Recommendation to adopt Snow Removal Policy for General Aviation Ramp – This policy came about a few years ago due to one of the FBO's customer. It's a policy that we never had to exercise. This will apply to those aircraft that are parked on the GA ramp. These aircraft shall be moved within 12 hours following the snowfall of 1 inch or more. If they are not, the aircraft owners or the lessees will be responsible for the expense of moving the aircraft and clearance of the accumulated snow around the said aircraft. Our snow removal schedule is 2 – 12 hour shifts. Once we clean the area they can park on the ramp, but they cannot stay there more than 12 hours as this will impede our snow removal process. Moved by Erickson, seconded by Rix. **MOTION CARRIED.** Caven, AFS stated as a user of the airport and with the weather that we've had for the last couple months, he likes to commend the people that work on the ramp area and the airport staff. They've done great job and appreciated all what they've done; Thank you.

Item #9 Recommendation to pay Helms & Associates invoice #1 in the amount of \$8,400.32 for Design Services for SRE Expansion, 3% complete, on AIP Proj. #3-46-0001-58-2026 – Construction for the expansion of the SRE building is scheduled for 2027. Moved by Rix, seconded by Erickson. **MOTION CARRIED.**

Item #10 Recommendation to pay Helms & Associates invoice #5 in the amount of \$762.50 for Assistance on PCU Purchase as per LOA dated June 17th, 2025, AIP Proj. #3-46-0001-57-2025 – Unit installation will start in April, possibly late March. Schwab asked if there is a max amount on the LOA. This LOA is not to exceed \$50,000 and Schmit stated they will be under. Moved by Erickson, seconded by Rix. **MOTION CARRIED.**

Item #11 Recommendation to pay Helms & Associates invoice #10 in the amount of \$4,836.64 for Construction Administration and Resident Engineering Services on AIP Proj. #3-46-0001-53-2025/AIP(AIG) #54-2025 Terminal Access Road and Parking Lot Improvements – Project is substantially complete. Waiting on some close-out documents from the contractors. Dahme is working with their subs on making all the quantities are in order. Schmit will possibly submit a change order next month. Moved by Rix, seconded by Erickson. **MOTION CARRIED.**

Item #12 Recommendation to pay Helms & Associates invoice #25 in the amount of \$304.45 for Construction Administration Services on AIP Proj. #3-46-0001-52-2024 GA Apron Reconstruction Phase 2 – Working on the Financial Closeout to submit to the FAA. This grant is at 90% reimbursed, so no reimbursement will be received until the Financial Closeout has been reviewed and approved by the FAA. The City can request up to 97.5% reimbursement if they wish as the FAA review process takes time. Moved by Erickson, seconded by Rix. **MOTION CARRIED.**

Item #13 Recommendation to pay Helms & Associates invoice #28 in the amount of \$460.37 for Construction Administration Services on AIP Proj. #3-46-0001-49-2023, Runway 13/31 Rehab and Lighting Improvements – Eframson received all the new lighting from Airport Lighting Company. They've selected an area where 21 new lights are installed. Now, we wait for a sub-zero temperature to test the heater units to make sure that they are not going to fail. There's a total of 85 lights received and that will need to be replaced. This is another project that will be ready for closeout and FAA has been kept on the loop on the issues. Moved by Erickson, seconded by Rix. **MOTION CARRIED.**

Item #14 Manager's Report

Airline Operations:

December 2025:

Enplanements	2,430	up 7.76% from last year
Deplanements	2,222	up 8.71% from last year
Total Passenger Traffic	4,652	up 8.21% from last year
Load Factor	82.48%	
YTD – Load Factor	70.75%	

December - Cancellations and Major Delays: Total of 21 events of which 3 are due to maintenance, 4 are due to weather and 14 are due for other.

Sun Country Flight: March 15th

2025 Monthly Total Fuel Statistics: November 2025 vs 2024 up 0.91%. December 2025 vs 204 up 0.42%.

2025 Monthly Car Rental: November 2025 vs 2024 up 17.2%.

Construction, projects, and other notes:

- AIP #58 SRE Building Expansion – Design: Helms is working on preliminary design.
- AIP #57 VALE/ZEV Voluntary Airport Low Emissions/Zero Emissions Vehicles – PCA: Awaiting documentation from contractors. Start date April 1st, 2026.
- AIP #55/AIG#56 Terminal Remodel and Expansion: Project funding is by the SD Terminal Program (SB144-2024) \$1.2 million, AIG (Airport Infrastructure Grant-Federal) \$800,000 and Local share. Start date April 1st, 2026. First construction meeting held on January 12th.

- AIP #53/AIG #54 Access Road and Parking Lot Reconstruction: Project is substantially complete. Retainage reduced to 5%.
- AIP #52 – GA Apron Reconstruction Phase II: Closeout in-progress.
- AIP #49 & #50 (BIL) – Rwy 13/31 Rehabilitation and Lighting Improvements: Replacement lights for runway edge lighting has been received by Eframson. Eframson has replaced 21 fixtures out of 85 and waiting on sub-zero weather to test the heating (arctic kits).
- Airport Certification and Safety Inspection: Received both 2024 and 2025 Closeout Inspection Letter. Certification Inspection for 2026 is scheduled for July 22nd through 24th.
- BCEM Tabletop review: In-person meeting to start in January for the June 2026 Triennial exercise.
- Virtower (Electronic Tower): Total operations for the month of December are at 884 of which 116 is SkyWest operations. 2026YTD operations are at 15,633. Erickson asked if this report would show what type of aircraft we had an increase in operations.
- Winter Weather Summary: The total expense through January 8th is \$83,638.01.

There being no other business to come before the Board, Erickson moved to adjourn, seconded by Rix. The meeting adjourned at 11:06AM.

Approved By Aberdeen Airport Board:

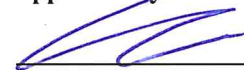

 Tony Schwan, Chair



 Date



City of Aberdeen

K.O. Lee Aberdeen Public Library
215 4th Ave. Southeast
Aberdeen, South Dakota 57401
(605)-626-7097

Library Board of Trustees Meeting Minutes
Tuesday, January 6, 2026, at 5: 15 PM

The K.O. Lee Aberdeen Public Library Board of Trustees met on Tuesday, January 6, at 5:15 PM at the Public Library. Present were Board Members Lynn Klundt, Troy McQuillen, Nicole Heinz, Peter Ramey and Cindy Senger.

Minutes

Troy McQuillen moved that the minutes of December 2, 2025, meeting be approved. The motion was seconded by Peter Ramey. Motion carried 5-0.

Open Forum

No one presented.

Director's Report

Assistant Library Director presented a report on happenings and news from the month of December 2025 and the programs and events planned for 2026.

Financial Matters

The December list of bills and financial statements was reviewed. A motion was made by Nicole Heinz that the December bills be paid and that the financial reports be received and placed on file. Troy McQuillen seconded. The motion carried 5-0.

New Business

Cara Perrion, Assistant Director, asked for funding for staff training. DiSC Communication training and to supplement the Extreme Ownership training encouraged by City Manager, Dave McNeil. Dave McNeil was present and mentioned that they city would supplement the Extreme Ownership training. Cindy Senger made a motion was made for the library board to provide \$3000 for DiSC Training for the library staff. Nicole Heinz seconded the motion. The motion carried 5-0.

Old Business

Complete updated list of library goals provided.

Executive Session

Motion made by Cindy Senger to go into Executive Session to discuss personnel and legal matters, pursuant to SDCL §1-25-2(1) and (3). No Board action can occur during executive session, but Board action may follow executive session. Those present in addition to the Library Board trustees were HR Director Kristin Kroell and Dave McNeil, City Manager. Motion seconded by Peter Ramey. Motion carried 4-0.

Motion made by Peter Ramey to go end Executive Session. Seconded by Cindy Senger. Motion carried 4-0. A motion was made by Cindy Senger to adjourn meeting. Peter Ramey seconded. The motion carried 4-0.

Motion made by Troy McQuillen to adjourn meeting. Peter Ramey seconded. The motion carried 4-0.

Its 

MINUTES
ABERDEEN CITY PLANNING COMMISSION
November 18, 2025

The City Planning Commission was called to order by Chairman Dean Marske. Members present at roll call were Marske, Fjeldheim, Lien, Schumacher, Mitchell and Zens. Also, present were Ken Hubbart, Community Development Director, Eric Miller, City Planner, and Emily Ellingson, Planning Commission Secretary.

Fjeldheim moved, and Zens seconded, to approve the Aberdeen City Planning Commission Minutes of September 30, 2025, all members voting aye, the motion carried.

OPEN FORUM – No one was present.

There being no old business, Acting Chairman Marske began with new business as follows:

- 1) Petition to Rezone from (C-3) Central Business District to (R-3) High Density Residential District described as “Lot 2, Block 4, North Aberdeen Addition, in the NE¼ of Section 13, Township 123 North, Range 64 West of the 5th P.M., Brown County, South Dakota,” (a.k.a. 119 Washington Street North – two blocks west of Roncalli Primary School). Eric Miller stated the petitioner is requesting this petition to rezone in order to bring the property into a district that is consistent with its use as a single-family residential dwelling. Following discussion, Lien moved, and Schumacher seconded to approve this item, all members voting aye, the motion carried.

- 2) An ordinance to change the name of a portion of public right-of-way from Nicklaus Drive to Shortridge Drive. Eric Miller stated this ordinance is requested in order to change the name of a portion of public right-of-way. This request originates from some newly found inconsistencies in the labeling of this section of R.O.W. within multiple plats of this area. From the first plat of this area through over a dozen replats, this section of R.O.W. has been called out as Palmer Drive, Shortridge Drive, and Nicklaus Drive. Nicklaus Drive appears to be the most prevalent reference; however, city and county maps all refer to it as Shortridge Drive as do the street signs in the area. The adjacent residents all use Shortridge Drive as their address as well. Approval of this ordinance appears to be the most efficient way of correcting any past errors or inconsistencies in the numerous plats in this area. Following discussion, Mitchell moved, and Fjeldheim seconded to approve this item, all members voting aye, the motion carried.

OTHER BUSINESS:

There being no further business before the Commission, Schumacher moved, and Lien seconded, to adjourn the meeting, all members voting aye, the motion carried.

Submitted by,

Emily Ellingson
Planning Commission Secretary
November 18, 2025

MINUTES
BOARD OF ZONING ADJUSTMENT
January 8, 2026

The Board of Zoning Adjustment Meeting was held on Thursday, January 8, 2026, in the Aberdeen City Hall, First Floor Council Chambers, Aberdeen, South Dakota with Babcock presiding as Chairman. Chairman Babcock called the meeting to order. Members present at roll call were Gardner, Weigel, Babcock, Sommers and Schumacher. Also present were Eric Miller, City Planner, Ken Hubbart, Community Development Director, Barry Dunlavy, Building Official, Benjamin Phillips, GIS Coordinator, Mike Hepola, Code Enforcement Officer, Paula Nelson, City Planner, Destin Spellman, Assistant City Engineer and Emily Ellingson, Board of Zoning Adjustment Secretary.

Gardner moved, and Sommers seconded, to approve the Board of Zoning Adjustment Minutes of December 11, 2025, all members voting aye, the motion carried.

OPEN FORUM – No one was present.

Paula Nelson recited the Board of Zoning Adjustment Meeting Information and Procedure Statement.

OLD BUSINESS – None.

NEW BUSINESS:

- 1) Padgett Auto Sales and Old Hickory requested permission, as per site plan submitted, to permit the expansion of open storage and sale of storage sheds, which would be a Special Exception in the (C-2) Highway Commercial District, all on Lot 1, Northwest Realty, a.k.a. 805 Sixth Ave SW. Tim Padgett was present to represent the property.

Staff's report included findings and recommendation for approval of the Special Exception upon conditions. Gardner moved, and Schumacher seconded to approve the Special Exception upon the following conditions: (1) This Special Exception is for Padgett Auto Sales and Old Hickory only, as long as they are the owner/operator of the proposed use and in compliance with all conditions applied to this Special Exception. (2) All storage sheds and other materials associated with the business must be neatly organized and stored appropriately. (3) The property itself must be properly maintained. (4) No junk (vehicles/equipment), debris, discard, building material waste, or trash may be stored on site. (5) Vegetation growth (volunteer trees, grass and weeds) must be maintained. (6) Corner visibility triangles must be kept clear. (7) Sheds over 200 square feet shall be secured from overturning during 115 mph wind event. Temporary hold downs may be required per Building Official. (8) No more than 40 storage sheds may be stored on the property at any given time as determined by the Board following discussion. (9) The grassed area located North of existing detached garage shall be converted to a gravel surface, with completion no later than June 1, 2026. (10) All temporary signs must be immediately removed (or properly permitted) from storage sheds on display. (11) Sign permits must be obtained by January 22, 2026, for the face changes previously made to the freestanding sign (located on 727 6th Ave SW) and wall sign (located on East side of building). Tim Padgett verbally accepted the conditions of approval. Upon roll call, all members voting aye, the motion carried. **SPECIAL EXCEPTION CONDITIONALLY APPROVED.**

- 2) Consideration of possible revocation of Special Exception granted on July 13, 2023, for the open storage, parking and sale of vehicles and related items for Loren Feist d.b.a. Advance Automotive all on Lot 1, Clinton's First Subdivision, a.k.a. 720 Sixth Ave SW. Loren Feist was present to represent the property.

Staff's report included findings and recommendation for approval of the revocation of Special Exception. Schumacher moved, and Sommers seconded to approve the revocation of Special Exception. Upon further discussion, Schumacher moved, and Weigel seconded to table this item until the February 12, 2026, Board of Zoning Adjustment meeting. Upon roll call, all members voting aye, the motion carried.

OTHER BUSINESS:

- 1) Schumacher opened nominations by nominating Bob Babcock for Chairman. Sommers seconded the nomination. There being no further nominations for Chairman, all members voting aye to elect Bob Babcock as Chairman, the motion carried.
- 2) Schumacher opened nominations by nominating Don Weigel for Vice-Chairman. Sommers seconded the nomination. There being no further nominations for Vice-Chairman, all members voting aye to elect Don Weigel as Vice-Chairman, the motion carried.

There being no further business before the Board, Weigel moved, and Sommers seconded, to adjourn the meeting, all members voting aye, the motion carried.

Emily Ellingson
Board of Zoning Adjustment Secretary
January 8, 2026



Home Day Care Operator License Application

Finance Office
123 South Lincoln Street
Aberdeen, SD 57401 | 605-626-7023 | records@aberndeen.sd.us

- New
- Renewal
- Transfer

Home Day Care Operator License is for a home with more than six and under twelve children (including the provider's own children who are under the age of six years) being cared for at any one time and which is insured only by a commercial insurance policy covering in-home childcare.

Section 1: Home Day Care Operator/Applicant Information		
Last Name	<u>Eisenbeisz</u>	First Name <u>Carol</u>
Doing Business As (DBA if applicable):		
Street Address (NO PO Box):	[REDACTED]	City, State, and Zip Code: <u>Aberdeen SD 57401</u>
Phone Number:	[REDACTED]	Email: [REDACTED]
Section 2: Additional Background Questions (all questions must be answered)		
1. How many children do you expect to care for?	<u>6</u>	2. What age will the children be? <u>6wks - 5yrs</u>
3. Do you own the premises where the home day care is to be operated?		<input checked="" type="checkbox"/> Yes <input type="checkbox"/> No
If no, please provide the name, address, and phone number of the legal owner of the property:		
Property Owner First and Last Name	Address, City, State, Zip Code	Phone number
4. Are you now or have you ever been listed on the South Dakota Registry for Abuse and Neglect, or any similar registry list maintained by another state?		<input type="checkbox"/> Yes <input checked="" type="checkbox"/> No
If yes, please list the state(s):		
5. Are you now or have you ever been listed on the South Dakota Sex Offender Registry, or any similar registry or list maintained by another state?		<input type="checkbox"/> Yes <input checked="" type="checkbox"/> No
If yes, please list the state(s):		
6. Have you been convicted of a felony within the last five (5) years?		<input type="checkbox"/> Yes <input checked="" type="checkbox"/> No
7. Do you have a current CPR and First Aid Certification? (Please provide copies)		<input checked="" type="checkbox"/> Yes <input type="checkbox"/> No
8. Are you currently registered with the Department of Social Services (DSS)? <small>(For information on registering with DSS, please call 605-626-3160 or DSSRegion5EA@state.sd.us)</small>		<input type="checkbox"/> Yes <input checked="" type="checkbox"/> No
Section 3: Request to make Day Care Contact Information Public		
<input type="checkbox"/> YES	I want the City of Aberdeen to include the information in Section 1 on a publicly available listing of licensed Home Day Cares. I understand the City will disclose my contact information but will make no recommendations as to the fitness, quality, or acceptability of any individual Home Day Care, other than that such Home Day Care is Duly Licensed by the City.	
<input checked="" type="checkbox"/> NO		

CONSENT TO DISCLOSURE: By signing below, Applicant consents to the following: (1) to disclosure by the South Dakota Department of Social Services of information regarding whether Applicant is listed on the South Dakota Central Registry for Abuse and Neglect; and (2) to disclosure by the South Dakota Division of Criminal Investigation and any other local, state, or federal law enforcement agency or child welfare agency of all information from any state or national criminal history record check of Applicant.

All individuals living in the household must consent to a background check. Failure to comply will result in denial, suspension, and/or revocation of your license and/or application.

I certify that the statements made herein are true and correct to the best of my knowledge.

2-17-2026
Date

Carol Eisenbeisz
Signature
Carol Eisenbeisz
Printed Name



HOME DAY CARE LICENSE

Staff Routing Sheet For License Renewals

Renewal Licensee/Applicant's Name, Address and City License Number (if renewal):

Carol Eisenbeisz, [REDACTED] Aberdeen | Ph [REDACTED] License Number: [REDACTED]

FIRE MARSHAL: Approve Disapprove

Max Stoltenburg
Max Stoltenburg (Feb 18, 2026 10:27:28 CST)
(Signature)

POLICE: Approve Disapprove

Tanner Jondahl
Tanner Jondahl (Feb 17, 2026 15:39:04 CST)
(Signature)

Nothing E-courts or Flex

CITY ATTORNEY: Approve Disapprove

Ron Waser
Ron Waser (Feb 17, 2026 15:43:51 CST)
(Signature)

COMM. DEVEL.: Approve Disapprove

Ken Hubbart
Ken Hubbart (Feb 17, 2026 16:48:30 CST)
(Signature)

FINANCE OFFICE: Approve Disapprove

Steven Thithavong
Steven Thithavong (Feb 17, 2026 15:39:35 CST)
(Signature)

CPR & 1st Aid Exp: 1/31/2027, Ins. Exp: 11/3/2026

After all approvals have been obtained, please issue the licensee/applicant a Renewal License for Home Day Care.

**NOTICE OF HEARING OF THE ABERDEEN CITY COUNCIL
REGARDING A PETITION TO REZONE CERTAIN PROPERTY**

A public hearing will be held by the Aberdeen City Council on the 23rd day of March, 2026, beginning at 5:30 p.m. in the City Council Chambers, 123 South Lincoln Street, First Floor of the Municipal Building, to consider the petition filed by Thomas Miller to amend Ordinance No. 1164 to rezone the following described property from its present zoning designation of A-1 District to R-2 District, said property being described as follows:

Lot 12, Gugel's First Subdivision in the SW ¼ of Sec. 6-T123N-R63W

The public is invited to attend the hearing and to present testimony and comments pertaining to the petition to amend Ordinance No. 1164 to rezone the above-described property. At the conclusion of the hearing, the council may adopt first reading of Ordinance 26-03-01 granting the petition to amend Ordinance No. 1164 and granting the petition to rezone said property.

This notice was received and placed on file as set forth in the consent agenda of the regular meeting of the City Council for February 23, 2026.

Dated this 23rd day of February 2026.

/s/Jordan McQuillen
Finance Officer



Petition to Rezone Planning Commission

123 South Lincoln Street
Aberdeen, SD 57401
605-626-7017

The Planning Commission Board meets the 3rd Tuesday of each month at 6:00 P.M. or 7:00 P.M. in the Council Chambers on the first floor of City Hall. Fees: \$250.00

Mayor and City Council:

I/We, the undersigned, do hereby petition the City Council of Aberdeen, South Dakota, to rezone property as follows:

Petitioner Information					
Petitioner/Title/(s):	Thomas Miller				
Phone:	[REDACTED]				
Mailing Address:	[REDACTED]				
City:	Aberdeen	State:	SD	Zip:	57401

Property Information					
Address/Location:	903 25th Ave NE, Aberdeen, SD 57401				
Legal Description:	Vacant lot Lot 12, Gugel's First Subdivision in the SW 1/4 of Sec. 6 - T123N-R63W				
Current Zoning:	A-1	Proposed Zoning:	R-2	PAID FEB 17 2026 CITY FINANCE OFFICE ABERDEEN, SOUTH DAKOTA	
Size of Parcel:	1.03 Acres				
Existing Land Use:	None				

Purpose of Petition
Plan to put a house on the property and live there.

	2/16/2026
Signature	Date

Office Use Only					
Ordinance No:	26-03-01				
Date:	2/17/26	Receipt #	R01562028	Fee:	250 ⁰⁰
Sign Issued <input checked="" type="checkbox"/>	Site Plan <input type="checkbox"/>				
PC Meeting:	3/17/26	1 st Reading:	3/23	2 nd Reading/Final Adoption:	4/16/26
Received By:	EM				

Rezone Overview

Address: 903 25th Ave NE

Legal Description: Lot 12, Gugel's First Subdivision in the SW1/4 of Sec. 6-T123N-R63W Addition.

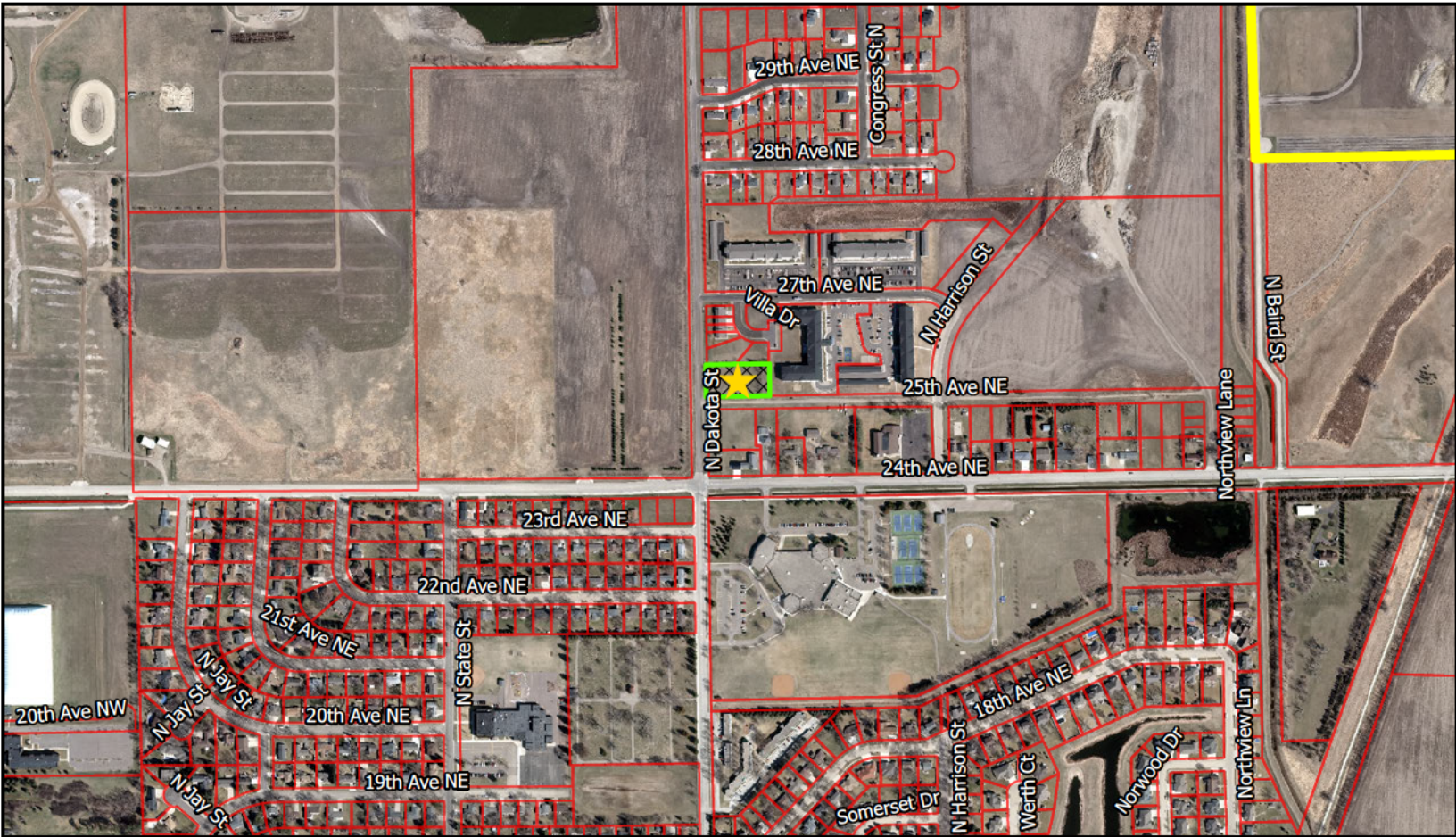

For Advisory purposes only; not a legal document.



Rezone Proposal

Address: 903 25th Ave NE

Legal Description: Lot 12, Gugel's First Subdivision in the SW1/4 of Sec. 6-T123N-R63W Addition.

Current Zoning: A-1 (Agricultural District)

Proposed Zoning: R-2 (Medium Density Residential)

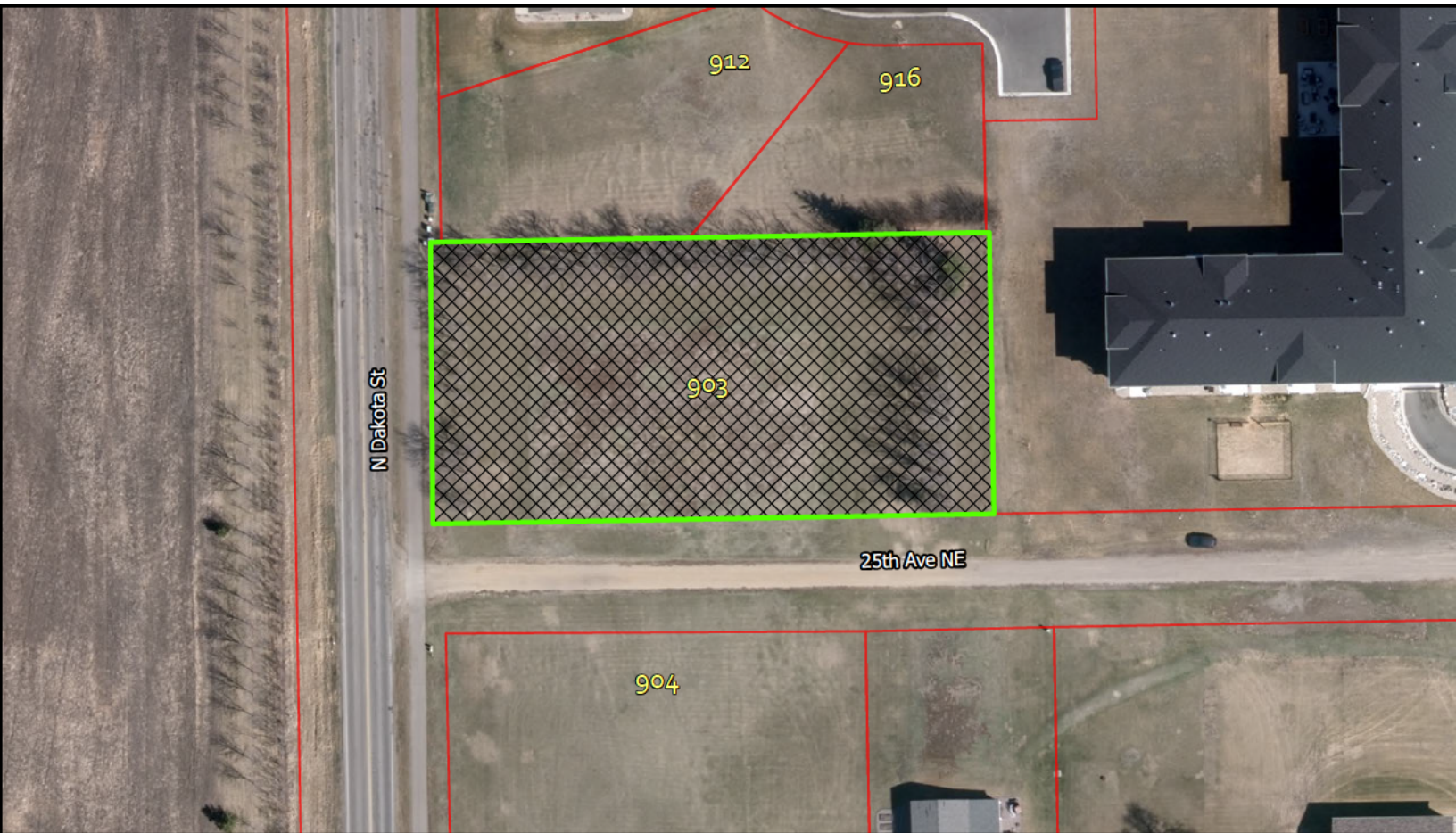

Ordinance No: 26-03-01 Date: 2/19/2026



City of Aberdeen

Council Agenda Memo

Agenda Item **6A**

Meeting Date:	2/23/2026	Department:	City Council
Agenda Section:	Old Business	Presented by:	City Attorney City Forester
Res./Ord. Number:	26-02-01	Attachments:	2

Agenda Item Title:

Possible final adoption of Ordinance No. 26-02-01 amending the landscape regulations to permit artificial turf.

Proposed or Possible Action:

Motion by _____, second by _____ to approve second reading and final adoption of Ordinance No. 26-02-01 amending the landscape regulations at Chapter 56 of the Aberdeen City Code to permit artificial turf.

Overview:

Ordinance No. 26-02-01 amends the Landscape Standards in Chapter 56 to permit artificial turf in non-residential districts. As an acceptable compromise to the overall conservation and beautification purposes of the Landscape Standards, the ordinance grants flexibility with landscape design for those challenging natural growth areas on a property. The proposed ordinance defines “artificial turf” and adds a new Sec. 56-127 setting stringent standards for the design, installation, maintenance, and application of artificial turf for up to 10% of the required living ground cover area. Sec. 56-3 is amended to provide the right to appeal to the Forestry Committee for a variance to increase the amount of artificial turf to not more than 15% of the living ground cover area. The City Forester does not oppose the proposed changes. The Parks Board considered the amendment at its February 4, 2026, meeting and recommended the Council adopt the ordinance. Administration recommends approval.

Financial Consideration:

NA

Attachments:

1. Ordinance No. 26-02-01
2. Proposed ordinance if all changes adopted

First Reading: _____
Second Reading: _____
Final Adoption: _____
Published: _____
Effective Date: _____

ORDINANCE NO. 26-02-01

AN ORDINANCE AMENDING THE ABERDEEN CITY CODE TO INCORPORATE ARTIFICIAL TURF INTO LANDSCAPE STANDARDS

WHEREAS, the City Council of the City of Aberdeen is charged with providing for the general welfare and property of its citizens, and does so, in part, through adoption of landscape standards codified in the Aberdeen City Code for the beautification of the community; and

WHEREAS, the City Council has determined that the following ordinance amending the landscape standards will promote the beautification of the City while also protecting the general welfare, health, safety, and property of its citizens.

BE IT ORDAINED BY THE CITY OF ABERDEEN THAT THE FOLLOWING CHANGES AND ADDITIONS SHALL BE MADE TO THE ABERDEEN CITY CODE:

1. Sections 56-3 and 56-111 of Chapter 56 – VEGETATION are hereby amended with ~~strickethrough~~ indicating text to be deleted, underline indicating text to be added, and the remainder of the Chapter to be left unaffected::

Sec. 56-3. Appeals.

(a) In deciding an appeal, the forestry committee shall have the authority:

- (1) To modify or revoke an order regarding removal, planting, and trimming of trees or plants; ~~or~~
- (2) In the case of landscape standards under article IV of this chapter, to consider alternate placement of trees and shrubs and shall have the authority to waive numerical requirements including islands; or
- (3) To increase the amount of artificial turf permitted under section 56-216(c)(2) to not more than 15% of the total ground cover area required to be landscaped.

(b) The decision of the forestry committee may be appealed to the city council if requested by either party in writing to the city manager or the city attorney within ten business days of the forestry committee's decision. The party requesting the appeal to the city council

bears the burden of proof. The standard of proof to be used by the city council is by a preponderance of the evidence. The city council shall have the power to overrule the actions or decisions of the forestry committee with a vote of not less than two-thirds of its entire membership.

Sec. 56-111. Definitions.

The following words, terms and phrases, when used in this article, shall have the meanings ascribed to them in this section, except where the context clearly indicates a different meaning:

Artificial turf means a dense and continuous surface of synthetic fibers mounted on a permeable backing and of sufficient density and green color to replicate the appearance of healthy, natural grass.

...

2. A new section shall be added to Chapter 56 – VEGETATION, Article IV. LANDSCAPE STANDARDS, Division 2. DISTRICT REQUIREMENTS, Subdivision III. Nonresidential Districts, as follows

Sec. 56-216. Artificial turf.

(a) *Approval required.* It is unlawful for any person to use artificial turf in violation of this section. Any person who wishes to use artificial turf in a permitted district shall first obtain approval from the city forester pursuant to this section and pay all applicable fees.

(b) *Certain districts.* Artificial turf may not be used to satisfy landscape standards in any residential zoning district but, upon approval, may be permitted in the following nonresidential zoning districts:

- (1) C-1 Neighborhood commercial district;
- (2) C-2 Highway commercial district;
- (3) C-3 Central business district;
- (4) I-1 Industrial park district;
- (5) I-2 Unrestricted industrial district;
- (6) Municipal, state and county use district; and
- (7) Health care district.

(c) *Design.* Artificial turf shall comply with all of the following design standards and shall:

- (1) Simulate the appearance of live turf, organic turf, grass, sod or lawn, and must replicate real live grass (i.e., green);
- (2) Not exceed 10% of the total ground cover area required to be landscaped;
- (3) Not encroach upon the 120 square feet planting areas for trees or shrubs;

- (4) Be a type known as cut pile infill with pile fibers of a minimum height of 1.5 inches and a maximum height of 2.5 inches;
- (5) Have a minimum face weight of 80 ounces per square yard;
- (6) Be manufactured from polyethylene yarn, dual yarn system, and manufactured in the United States;
- (7) Have backing that is water permeable; and
- (8) Be new product, not previously installed elsewhere.

(d) *Installation.* Artificial turf shall comply with all of the following installation standards and shall:

- (1) Be installed over a subgrade prepared to provide positive drainage and installed on an evenly graded, porous crushed rock aggregate material that is a minimum of three inches in depth; and
- (2) Be anchored at all edges and seams consistent with the manufacturer's specifications and:
 - a. Not have visible seams between panels;
 - b. Have seams that are joined in a tight and secure manner; and
 - c. Have an infill medium consisting of clean silica sand or other mixture, pursuant to the manufacturer's specifications that shall:
 - 1. Be brushed into the fibers to ensure that the fibers remain in an upright position;
 - 2. Provide ballast that will help hold the turf in place; and
 - 3. Provide a cushioning effect; and
- (3) Be installed by a qualified general or landscape contractor.

(e) *Maintenance.* Artificial turf shall comply with all of the following maintenance standards and shall:

- (1) Be maintained in an attractive and clean condition, and shall not contain holes, tears, stains, discoloration, seam separations, uplifted surfaces or edges, heat degradation or excessive wear.
- (2) Be maintained in a green fadeless condition and free of weeds, debris, and impressions.
- (3) Damaged or worn areas in the artificial turf must be repaired, or removed and replaced, in a prompt manner and repaired in a form and manner

acceptable to the city. Artificial turf must be removed and replaced once it is unable to be maintained as required.

- (4) If the city identifies a maintenance, repair, or replacement issue, it shall be resolved in a form and manner acceptable to the city within six months of written notification to the property owner.

(f) *Applications.* Applications to the city forester for use of artificial turf shall be accompanied by:

- (1) Brand and type of artificial turf, including manufacturer specifications and warranties showing the turf:
 - a. Complies with all applicable ASTM standards, including but not limited to ASTM F2765 and F1551;
 - b. Has a warranty of not less than 15 years against UV degradation, fiber breakdown, and seam failure;
 - c. Yarn and backing performance ratings include UV stabilization, heat resistance, and permeability;
 - d. Meets all federal CPSC lead limits and contains no intentionally added heavy metals;
 - e. Must be permeable and drain water; and
 - f. Color fastness meets ASTM G154 or similar rating;
- (2) A scaled cross-section and details of the proposed materials and installation, including but not limited to subgrade, drainage, aggregate base or leveling layer, and infill; and
- (3) An up-to-date survey of the property.

(g) *Abatement.* A violation of this section may be abated, including removal, as set forth under section 56-2, which order may be appealed as provided under section 56-3. The remedy of abatement shall be in addition to all other remedies available including prosecution for a violation of this section.

3. **Severability.** The provisions of this ordinance are severable. If any provision of this ordinance or the application thereof to any person or circumstance is held to be invalid, such invalidity shall not affect other provisions or applications of this ordinance which can be given effect without the invalid provision or application.

4. **Effective Date.** The City Finance Officer shall cause this ordinance to be published in the official newspaper in clean text with all deletions and additions incorporated therein and footnotes omitted. This ordinance shall become effective twenty (20) days after the completed publication unless the referendum is invoked.

Travis Schaunaman, Mayor

ATTEST:

Jordan McQuillen, Finance Officer

PROPOSED ORDINANCE IF ALL CHANGES ADOPTED

First Reading: _____

Second Reading: _____

Final Adoption: _____

Published: _____

Effective Date: _____

ORDINANCE NO. 26-02-01

**AN ORDINANCE AMENDING THE ABERDEEN CITY CODE
TO INCORPORATE ARTIFICIAL TURF INTO LANDSCAPE STANDARDS**

WHEREAS, the City Council of the City of Aberdeen is charged with providing for the general welfare and property of its citizens, and does so, in part, through adoption of landscape standards codified in the Aberdeen City Code for the beautification of the community; and

WHEREAS, the City Council has determined that the following ordinance amending the landscape standards will promote the beautification of the City while also protecting the general welfare, health, safety, and property of its citizens.

**BE IT ORDAINED BY THE CITY OF ABERDEEN THAT THE FOLLOWING
CHANGES AND ADDITIONS SHALL BE MADE TO THE ABERDEEN CITY
CODE:**

1. Sections 56-3 and 56-111 of Chapter 56 – VEGETATION are hereby amended with ~~strickethrough~~ indicating text to be deleted, underline indicating text to be added, and the remainder of the Chapter to be left unaffected::

Sec. 56-3. Appeals.

(a) In deciding an appeal, the forestry committee shall have the authority:

- (1) To modify or revoke an order regarding removal, planting, and trimming of trees or plants;
- (2) In the case of landscape standards under article IV of this chapter, to consider alternate placement of trees and shrubs and shall have the authority to waive numerical requirements including islands; or
- (3) To increase the amount of artificial turf permitted under section 56-216(c)(2) to not more than 15% of the total ground cover area required to be landscaped.

(b) The decision of the forestry committee may be appealed to the city council if requested by either party in writing to the city manager or the city attorney within ten business days of the forestry committee's decision. The party requesting the appeal to the city council

PROPOSED ORDINANCE IF ALL CHANGES ADOPTED

bears the burden of proof. The standard of proof to be used by the city council is by a preponderance of the evidence. The city council shall have the power to overrule the actions or decisions of the forestry committee with a vote of not less than two-thirds of its entire membership.

Sec. 56-111. Definitions.

The following words, terms and phrases, when used in this article, shall have the meanings ascribed to them in this section, except where the context clearly indicates a different meaning:

Artificial turf means a dense and continuous surface of synthetic fibers mounted on a permeable backing and of sufficient density and green color to replicate the appearance of healthy, natural grass.

...

2. A new section shall be added to Chapter 56 – VEGETATION, Article IV. LANDSCAPE STANDARDS, Division 2. DISTRICT REQUIREMENTS, Subdivision III. Nonresidential Districts, as follows

Sec. 56-216. Artificial turf.

(a) *Approval required.* It is unlawful for any person to use artificial turf in violation of this section. Any person who wishes to use artificial turf in a permitted district shall first obtain approval from the city forester pursuant to this section and pay all applicable fees.

(b) *Certain districts.* Artificial turf may not be used to satisfy landscape standards in any residential zoning district but, upon approval, may be permitted in the following nonresidential zoning districts:

- (1) C-1 Neighborhood commercial district;
- (2) C-2 Highway commercial district;
- (3) C-3 Central business district;
- (4) I-1 Industrial park district;
- (5) I-2 Unrestricted industrial district;
- (6) Municipal, state and county use district; and
- (7) Health care district.

(c) *Design.* Artificial turf shall comply with all of the following design standards and shall:

- (1) Simulate the appearance of live turf, organic turf, grass, sod or lawn, and must replicate real live grass (i.e., green);
- (2) Not exceed 10% of the total ground cover area required to be landscaped;
- (3) Not encroach upon the 120 square feet planting areas for trees or shrubs;

PROPOSED ORDINANCE IF ALL CHANGES ADOPTED

- (4) Be a type known as cut pile infill with pile fibers of a minimum height of 1.5 inches and a maximum height of 2.5 inches;
- (5) Have a minimum face weight of 80 ounces per square yard;
- (6) Be manufactured from polyethylene yarn, dual yarn system, and manufactured in the United States;
- (7) Have backing that is water permeable; and
- (8) Be new product, not previously installed elsewhere.

(d) *Installation.* Artificial turf shall comply with all of the following installation standards and shall:

- (1) Be installed over a subgrade prepared to provide positive drainage and installed on an evenly graded, porous crushed rock aggregate material that is a minimum of three inches in depth; and
- (2) Be anchored at all edges and seams consistent with the manufacturer's specifications and:
 - a. Not have visible seams between panels;
 - b. Have seams that are joined in a tight and secure manner; and
 - c. Have an infill medium consisting of clean silica sand or other mixture, pursuant to the manufacturer's specifications that shall:
 1. Be brushed into the fibers to ensure that the fibers remain in an upright position;
 2. Provide ballast that will help hold the turf in place; and
 3. Provide a cushioning effect; and
- (3) Be installed by a qualified general or landscape contractor.

(e) *Maintenance.* Artificial turf shall comply with all of the following maintenance standards and shall:

- (1) Be maintained in an attractive and clean condition, and shall not contain holes, tears, stains, discoloration, seam separations, uplifted surfaces or edges, heat degradation or excessive wear.
- (2) Be maintained in a green fadeless condition and free of weeds, debris, and impressions.
- (3) Damaged or worn areas in the artificial turf must be repaired, or removed and replaced, in a prompt manner and repaired in a form and manner

PROPOSED ORDINANCE IF ALL CHANGES ADOPTED

acceptable to the city. Artificial turf must be removed and replaced once it is unable to be maintained as required.

- (4) If the city identifies a maintenance, repair, or replacement issue, it shall be resolved in a form and manner acceptable to the city within six months of written notification to the property owner.

(f) *Applications.* Applications to the city forester for use of artificial turf shall be accompanied by:

- (1) Brand and type of artificial turf, including manufacturer specifications and warranties showing the turf:
 - a. Complies with all applicable ASTM standards, including but not limited to ASTM F2765 and F1551;
 - b. Has a warranty of not less than 15 years against UV degradation, fiber breakdown, and seam failure;
 - c. Yarn and backing performance ratings include UV stabilization, heat resistance, and permeability;
 - d. Meets all federal CPSC lead limits and contains no intentionally added heavy metals;
 - e. Must be permeable and drain water; and
 - f. Color fastness meets ASTM G154 or similar rating;
- (2) A scaled cross-section and details of the proposed materials and installation, including but not limited to subgrade, drainage, aggregate base or leveling layer, and infill; and
- (3) An up-to-date survey of the property.

(g) *Abatement.* A violation of this section may be abated, including removal, as set forth under section 56-2, which order may be appealed as provided under section 56-3. The remedy of abatement shall be in addition to all other remedies available including prosecution for a violation of this section.

3. **Severability.** The provisions of this ordinance are severable. If any provision of this ordinance or the application thereof to any person or circumstance is held to be invalid, such invalidity shall not affect other provisions or applications of this ordinance which can be given effect without the invalid provision or application.

4. **Effective Date.** The City Finance Officer shall cause this ordinance to be published in the official newspaper in clean text with all deletions and additions incorporated therein and footnotes omitted. This ordinance shall become effective twenty (20) days after the completed publication unless the referendum is invoked.

PROPOSED ORDINANCE IF ALL CHANGES ADOPTED

Travis Schaunaman, Mayor

ATTEST:

Jordan McQuillen, Finance Officer



City of Aberdeen

Council Agenda Memo

Agenda Item **6B**

Meeting Date:	2/23/2026	Department:	City Manager
Agenda Section:	Old Business	Presented by:	City Manager City Attorney
Res./Ord. Number:	26-02-11	Attachments:	2

Agenda Item Title:

Possible final adoption of Ordinance No. 26-02-11 regarding private ambulance services.

Proposed or Possible Action:

Motion by _____, second by _____ to approve second reading and final adoption of Ordinance No. 26-02-11 amending Chapter 20 of the Aberdeen City Code regarding private ambulance services.

Overview:

Ordinance No. 26-02-11 recognizes changes in state law in 2024 regarding ambulance and EMT licensing by the SD Dept. of Health. The amendment limits the City’s licensing authority to ground ambulances and streamlines the licensing process by relying on state licensing of the service and its drivers and permitting the finance officer to issue the City license. Requiring private ambulance services to operate within the city limits only if they are licensed by the City necessarily allows the 911-emergency ambulance service for the City and County operated by Aberdeen Fire Rescue / Advanced Care Ambulance, to operate more efficiently and grants the City control over persons purporting to provide ambulance services to its residents. The City’s only licensed private ambulance service, Aberdeen Ambulance Service, and AFR Chief Joel Weig support the proposed ordinance. Staff recommends approval.

Financial Consideration:

NA

Attachments:

1. Ordinance No. 26-02-11
2. Proposed ordinance if all changes adopted

First Reading: _____
Second Reading: _____
Final Adoption: _____
Published: _____
Effective Date: _____

ORDINANCE NO. 26-02-11

AN ORDINANCE AMENDING CHAPTER 20 – *EMERGENCY MANAGEMENT AND SERVICES* OF THE ABERDEEN CITY CODE REGARDING PRIVATE AMBULANCE SERVICE

WHEREAS, the City Council of the City of Aberdeen is charged with protecting the health, safety, and property of its citizens; and

WHEREAS, the City Council has determined that the following ordinance will protect the health, safety, and property of its citizens.

BE IT ORDAINED BY THE CITY OF ABERDEEN THAT THE FOLLOWING CHANGES AND ADDITIONS SHALL BE MADE TO THE ABERDEEN CITY CODE:

1. Division 2 of Article III, Ambulance Service, of Chapter 20 – EMERGENCY MANAGEMENT AND SERVICES is hereby amended with ~~strike through~~ indicating text to be deleted, underline indicating text to be added, and the remainder of the Chapter to be left unaffected:

Sec. 20-74. Definitions.

The following definitions shall apply to all terms used in this ~~division~~article unless the context clearly indicates or requires a different meaning.

Ambulance means any privately or publicly owned motor vehicle that is specifically designed or constructed, and equipped, and is intended to be used for and is maintained or operated for the ground transportation of patients.

Attendant means a trained and/or qualified individual responsible for the operation of an ambulance and the care of patients whether or not the attendant also serves as driver.

Attendant-driver means a person who is qualified as an attendant and a driver.

Driver means an individual who drives an ambulance.

Fire chief means the fire chief or other designated official, and includes city fire and rescue employees certified to provide emergency medical services.

Health officer means the city health officer or other designated official.

Patient means an individual who is sick, injured, wounded, or otherwise incapacitated or helpless and who requires an attendant.

Person means any individual, firm, partnership, association, corporation, company, group of individuals acting together for a common purpose, or organization of any kind, including any governmental agency other than the United States.

Sec. 20-75. Licensing of ambulance service.¹

Any person required by the state to be licensed as a ground ambulance service and that wishes to operate such an ambulance service as defined by SDCL 34-11-2 within the corporate limits of the city shall first be licensed pursuant to this division article and pay all applicable fees. No ambulance service shall be operated in the city unless the ambulance service has a currently valid license from the city to provide such service.

Sec. 20-76. Exemption from license requirement.

The following are exempt from the provisions of this division article:

- (1) An ambulance service operated by the city fire department; The occasional use of a privately owned vehicle or aircraft not ordinarily used in the business of ambulance service;
- (2) A vehicle rendering service as an ambulance in case of a major catastrophe or emergency when ambulance service is based on localities or catastrophe or emergency are insufficient or unavailable to render the services or when requested to do so by a law enforcement officer or fire departmental official;
- (23) An A ambulance services based outside the city in which either the patient pickup or delivery is conducted outside of the city.;
- (4) Vehicles owned and operated by rescue squads which are not regularly used as ambulances except as part of rescue operations;
- (5) Ambulances owned and operated by the city in the operation of a municipal ambulance service and by agencies of the state and federal government;

¹ **ARSD 44:05:02:05. License does not authorize service where otherwise prohibited.** Issuance of a license by the department does not authorize an ambulance service to locate its business within a county, municipality, or authority which requires its own license to operate an ambulance service.

Source 2 SDR 26, effective October 9, 1975; 6 SDR 93, effective July 1, 1980; 20 SDR 204, effective June 9, 1994.

General Authority: SDCL [34-11-5](#).

Law Implemented: SDCL [34-11-1](#), [34-11-3](#).

- ~~(6) — Coach services engaged by prior appointment and the transportation of infirm or disabled persons not requiring emergency medical care in transit;~~
- ~~(7) — Ambulance services whose trip originates outside the city and may have one or more destinations within the city;~~
- ~~(8) — Any air ambulance services.~~

Sec. 20-77. ~~Application for three-year license; appeal.~~

(a) ~~*Issuance.* The finance officer is authorized to ~~city council shall~~ approve the license application of any ambulance service making such application and paying the necessary fees upon a finding of public convenience and necessity. A license issued under this ~~division~~ article shall be valid for the period of the license issued by the state ~~three years from the date of issuance~~ unless earlier suspended, revoked, terminated, or surrendered.~~

(b) ~~*Application.* An application for an ambulance service license shall be made upon the forms as prescribed by the finance officer and shall contain; include a complete copy of the most current application, including all requested information, submitted by applicant to the state department or agency charged with issuing licenses for ambulance services. The finance officer may require such other information as deemed reasonably necessary to a fair determination of compliance with this article.~~

~~(c) *Appeal.* Appeal by the applicant from the decision of the finance officer to deny the license may be made to the city council upon request filed with the finance officer within 20 days of such decision.~~

- ~~(1) — The name and address of the applicant and of the owner of the ambulance service;~~
- ~~(2) — The trade or other fictitious name, if any, under which the applicant does business and proposes to do business;~~
- ~~(3) — The training and experience of the applicant in the transportation and care of patients;~~
- ~~(4) — A description of each ambulance, including the make, model, year of manufacture; current state license number; the length of time the ambulance has been in use; the insignia, name, monogram, or other distinguishing characteristics to be used to designate applicant's ambulance;~~
- ~~(5) — The location and description of the place from which it is intended to operate;~~
- ~~(6) — Such other information as the finance officer shall deem reasonably necessary to a fair determination of compliance with this article; and~~
- ~~(7) — Payment of the fee per ambulance for such license as provided in the city fee schedule on file in the office of the finance officer.~~

Sec. 20-78. Proof of state licenses and inspections.

Prior to the issuance of any ambulance service license, the applicant shall provide proof of all licenses issued by the state regulating the operation of ambulance services and the most current inspection records by any state department or agency charged with overseeing ambulance services certifying the ambulances, equipment, and premises designated in each application hereunder.

Sec. 20-79. ~~Reserved.~~ Investigation and report of findings.

~~The finance officer, within ten business days after receipt of a fully completed application for an ambulance service license, shall cause the investigation as he or she deems necessary to be made of the applicant and of the applicant's proposed operations. The finance officer thereafter shall report his or her findings to the city council and make a recommendation regarding the issuance of an ambulance service license.~~

Sec. 20-80. Compliance with Rules and regulations.

Each ambulance service licensed under this article shall comply with~~abide by~~ all federal, state, and local laws, regulations, and ordinances governing the operation of ambulance services, including patient care and transport, personnel, record keeping, medical and maintenance equipment, sanitary conditions, and necessary supplies.

Sec. 20-81. Business name on ambulances. ~~Advertisement of services and marking.~~

~~(a) — Each ambulance service licensed under this article shall be allowed only to advertise services and level of certified personnel actually provided by the ambulance service. No licensee shall make any false statement or misrepresentation of fact in carrying on the business for which the license is issued.~~

(b) — Each ambulance shall be clearly marked with the licensee's business name as registered with any state department or agency overseeing ambulance service, such mark to include the insignia, name, monogram, or other distinguishing characteristics used to designate the ambulance service.

~~(c) — Each ambulance, when transporting patients, shall have an attendant or attendant-driver present with the level of certification advertised in or on the ambulance.~~

Sec. 20-82. Reserved. ~~Ambulance standards generally.~~

~~(a) — Each ambulance, at all times when in use as such, shall meet the minimum standards prescribed by any state department or agency charged with overseeing ambulance services.~~

~~(b) — Equipment and supplies in each ambulance, at all times when the ambulance is in use as such, shall include all equipment and supplies required by any state department or agency charged with overseeing ambulance services.~~

~~(c) — Each ambulance shall be equipped with two-way FM radio equipment to hospitals.~~

Sec. 20-84. License nontransferable.

Any ambulance service license sold, assigned, mortgaged, or otherwise transferred without the approval of the city council and a finding of conformance with all the requirements of this [division article](#) as upon original licensing shall terminate the license. Any change of ownership or transfer of a licensed ambulance service shall require a new application and a new license and conformance with all the requirements of this [division article](#) as upon original licensing.

Sec. 20-85. Equipment, premises, and records to be available for inspection.

Each licensed ambulance service, its ambulances and equipment, the premises designated in the application, and all records relating to maintenance and operation as an ambulance service shall be open to inspection by the health officer, the fire chief, the finance officer, or their designated representative during usual hours of operation.

Sec. 20-86. Suspension, revocation, or termination of license.

(a) The city council may and is authorized to suspend or revoke an ambulance service license issued hereunder for failure of a licensee to comply and to maintain compliance with or for his or her violation of any applicable provisions, standards, or requirements of this [division article](#) or of regulations promulgated hereunder, or of any other applicable laws or ordinances or regulations promulgated thereunder, but only after warning and such reasonable time for compliance as may be set by the city council.

(b) Upon suspension, revocation, termination, or surrender of an ambulance service license issued ~~by the state or city under this division~~, the ambulance service shall cease operations as such and no person shall permit the ambulance service to continue operations.

~~**Sec. 20-87. Ambulance driver license required.**~~

~~No person shall operate within the city an ambulance under this division without first having obtained from the city council a driver license therefor and without having complied with all provisions of this division.~~

~~**Sec. 20-88. Attendant required for patient transport.**~~

~~No ambulance service licensed under this division may transport or carry for hire any patient in any ambulance within the city unless there shall be an attendant in the ambulance in addition to the driver thereof.~~

Sec. 20-90. Refusal of service.

After having responded to any call for ambulance service, an ambulance service licensed under this [division article](#) shall not refuse the service for any reason except where aid is declined by the prospective patient or for other reasons beyond the control of the licensee.

Sec. 20-91. Going to scene of accident without request.

An ambulance service licensed under this [division article](#) shall not go to the scene of any accident unless a request for ambulance service has been directed to the operator or driver of

the ambulance or to the place from which the ambulance operates or the ambulance happens upon the accident scene by chance.

2. **Severability.** The provisions of this ordinance are severable. If any provision of this ordinance or the application thereof to any person or circumstance is held to be invalid, such invalidity shall not affect other provisions or applications of this ordinance which can be given effect without the invalid provision or application.

3. **Effective Date.** The City Finance Officer shall cause this ordinance to be published in the official newspaper in clean text with all deletions and additions incorporated therein and footnotes omitted. This ordinance shall become effective twenty (20) days after the completed publication, unless the referendum is invoked.

Travis Schaunaman, Mayor

ATTEST:

Jordan McQuillen, Finance Officer

First Reading: _____
Second Reading: _____
Final Adoption: _____
Published: _____
Effective Date: _____

ORDINANCE NO. 26-02-11

AN ORDINANCE AMENDING CHAPTER 20 – *EMERGENCY MANAGEMENT AND SERVICES* OF THE ABERDEEN CITY CODE REGARDING PRIVATE AMBULANCE SERVICE

WHEREAS, the City Council of the City of Aberdeen is charged with protecting the health, safety, and property of its citizens; and

WHEREAS, the City Council has determined that the following ordinance will protect the health, safety, and property of its citizens.

BE IT ORDAINED BY THE CITY OF ABERDEEN THAT THE FOLLOWING CHANGES AND ADDITIONS SHALL BE MADE TO THE ABERDEEN CITY CODE:

1. Division 2 of Article III, Ambulance Service, of Chapter 20 – EMERGENCY MANAGEMENT AND SERVICES is hereby amended with ~~strike through~~ indicating text to be deleted, underline indicating text to be added, and the remainder of the Chapter to be left unaffected:

Sec. 20-74. Definitions.

The following definitions shall apply to all terms used in this article unless the context clearly indicates or requires a different meaning.

Ambulance means any privately or publicly owned motor vehicle that is specifically designed or constructed, and equipped, and is intended to be used for and is maintained or operated for the ground transportation of patients.

Attendant means a trained and/or qualified individual responsible for the operation of an ambulance and the care of patients whether or not the attendant also serves as driver.

Attendant-driver means a person who is qualified as an attendant and a driver.

Driver means an individual who drives an ambulance.

Fire chief means the fire chief or other designated official and includes city fire and rescue employees certified to provide emergency medical services.

Health officer means the city health officer or other designated official.

Patient means an individual who is sick, injured, wounded, or otherwise incapacitated or helpless and who requires an attendant.

Person means any individual, firm, partnership, association, corporation, company, group of individuals acting together for a common purpose, or organization of any kind, including any governmental agency other than the United States.

Sec. 20-75. Licensing of ambulance service.¹

Any person required by the state to be licensed as a ground ambulance service and that wishes to operate such ambulance service within the corporate limits of the city shall first be licensed pursuant to this article and pay all applicable fees. No ambulance service shall be operated in the city unless the ambulance service has a currently valid license from the city to provide such service.

Sec. 20-76. Exemption from license requirement.

The following are exempt from the provisions of this article:

- (1) An ambulance service operated by the city fire department;
- (2) An ambulance service based outside the city in which either the patient pickup or delivery is conducted outside of the city.

Sec. 20-77. License; appeal.

(a) *Issuance.* The finance officer is authorized to approve the license application of any ambulance service making such application and paying the necessary fees upon a finding of public convenience and necessity. A license issued under this article shall be valid for the period of the license issued by the state unless earlier suspended, revoked, terminated, or surrendered.

(b) *Application.* An application for an ambulance service license shall be made upon the forms as prescribed by the finance officer and shall include a complete copy of the most current application, including all requested information, submitted by applicant to the state department or agency charged with issuing licenses for ambulance services. The finance officer may require such other information as deemed reasonably necessary to a fair determination of compliance with this article.

¹ **ARSD 44:05:02:05. License does not authorize service where otherwise prohibited.** Issuance of a license by the department does not authorize an ambulance service to locate its business within a county, municipality, or authority which requires its own license to operate an ambulance service.

Source 2 SDR 26, effective October 9, 1975; 6 SDR 93, effective July 1, 1980; 20 SDR 204, effective June 9, 1994.

General Authority: SDCL [34-11-5](#).

Law Implemented: SDCL [34-11-1](#), [34-11-3](#).

(c) *Appeal.* Appeal by the applicant from the decision of the finance officer to deny the license may be made to the city council upon request filed with the finance officer within 20 days of such decision.

Sec. 20-78. Proof of state licenses and inspections.

Prior to the issuance of any ambulance service license, the applicant shall provide proof of all licenses issued by the state regulating the operation of ambulance services and the most current inspection records by any state department or agency charged with overseeing ambulance services certifying the ambulances, equipment, and premises designated in each application hereunder.

Sec. 20-79. Reserved.

Sec. 20-80. Compliance with rules and regulations.

Each ambulance service licensed under this article shall comply with all federal, state, and local laws, regulations, and ordinances governing the operation of ambulance services, including patient care and transport, personnel, record keeping, medical and maintenance equipment, sanitary conditions, and necessary supplies.

Sec. 20-81. Business name on ambulances.

Each ambulance shall be clearly marked with the licensee's business name as registered with any state department or agency overseeing ambulance service, such mark to include the insignia, name, monogram, or other distinguishing characteristics used to designate the ambulance service.

Sec. 20-82. Reserved.

Sec. 20-84. License nontransferable.

Any ambulance service license sold, assigned, mortgaged, or otherwise transferred without the approval of the city council and a finding of conformance with all the requirements of this article as upon original licensing shall terminate the license. Any change of ownership or transfer of a licensed ambulance service shall require a new application and a new license and conformance with all the requirements of this article as upon original licensing.

Sec. 20-85. Equipment, premises, and records to be available for inspection.

Each licensed ambulance service, its ambulances and equipment, the premises designated in the application, and all records relating to maintenance and operation as an ambulance service shall be open to inspection by the health officer, the fire chief, the finance officer, or their designated representative during usual hours of operation.

Sec. 20-86. Suspension, revocation, or termination of license.

(a) The city council may and is authorized to suspend or revoke an ambulance service license issued hereunder for failure of a licensee to comply and to maintain compliance with or for his or her violation of any applicable provisions, standards, or requirements of this article or of regulations promulgated hereunder, or of any other applicable laws or ordinances or regulations

promulgated thereunder, but only after warning and such reasonable time for compliance as may be set by the city council.

(b) Upon suspension, revocation, termination, or surrender of an ambulance service license issued by the state or city, the ambulance service shall cease operations as such and no person shall permit the ambulance service to continue operations.

Sec. 20-90. Refusal of service.

After having responded to any call for ambulance service, an ambulance service licensed under this article shall not refuse the service for any reason except where aid is declined by the prospective patient or for other reasons beyond the control of the licensee.

Sec. 20-91. Going to scene of accident without request.

An ambulance service licensed under this article shall not go to the scene of any accident unless a request for ambulance service has been directed to the operator or driver of the ambulance or to the place from which the ambulance operates or the ambulance happens upon the accident scene by chance.

2. **Severability.** The provisions of this ordinance are severable. If any provision of this ordinance or the application thereof to any person or circumstance is held to be invalid, such invalidity shall not affect other provisions or applications of this ordinance which can be given effect without the invalid provision or application.

3. **Effective Date.** The City Finance Officer shall cause this ordinance to be published in the official newspaper in clean text with all deletions and additions incorporated therein and footnotes omitted. This ordinance shall become effective twenty (20) days after the completed publication, unless the referendum is invoked.

Travis Schaunaman, Mayor

ATTEST:

Jordan McQuillen, Finance Officer



City of Aberdeen

Council Agenda Memo

Agenda Item 6C

Meeting Date:	2/23/2026	Department:	Finance
Agenda Section:	Old Business	Presented by:	Jordan McQuillen City Finance Officer
Res./Ord. Number:	Ord. 26-02-09	Attachments:	1

Agenda Item Title:

Possible approval of Second Reading and Final Adoption of Ordinance No. 26-02-09 approving sewer system improvements and authorizing issuance of a Clean Water SRF revenue bond

Proposed or Possible Action:

Motion and second to approve second reading and final adoption of Ordinance No. 26-02-09 approving sewer system improvements and authorizing issuance of a Clean Water SRF revenue bond

Overview:

This ordinance authorizes the City to finance improvements to the municipal sewer system through the South Dakota Clean Water State Revolving Fund (SRF) program. The ordinance approves the issuance of a sewer revenue bond in a principal amount not to exceed \$30,000,000, authorizes execution of the related loan agreement with the South Dakota Conservancy District, and establishes the required funds, accounts, and revenue pledges necessary to secure repayment.

The revenue bond is payable solely from sewer system revenues and a segregated project surcharge. The bond does not constitute a general obligation of the City and does not pledge the City’s taxing authority or general credit.

The ordinance also establishes a special surcharge district, authorizes periodic review and adjustment of rates to meet required debt service coverage, and provides for the administration of project revenue, debt service, depreciation, and surplus accounts in accordance with state law and SRF requirements.

There have been no changes to the ordinance since first reading on February 17, 2026.

Financial Consideration:

The ordinance authorizes financing for sewer system improvements in an amount not to exceed \$30,000,000 through the Clean Water SRF program. Debt service will be paid exclusively from sewer system revenues and a project-specific surcharge, with a required minimum coverage of 110% of annual debt service. There is no impact to the General Fund or property tax levy.

Attachments:

1. Ordinance 26-02-09

First Reading: _____
Second Reading: _____
Adopted: _____
Published: _____
Effective Date: _____

ORDINANCE NO. 26-02-09

ORDINANCE GIVING APPROVAL TO CERTAIN SEWER FACILITIES IMPROVEMENTS; GIVING APPROVAL TO THE ISSUANCE AND SALE OF A REVENUE BOND TO FINANCE, DIRECTLY OR INDIRECTLY, THE IMPROVEMENTS TO THE FACILITIES; APPROVING THE FORM OF THE LOAN AGREEMENT AND THE REVENUE BOND AND PLEDGING PROJECT REVENUES AND COLLATERAL TO SECURE THE PAYMENT OF THE REVENUE BOND; AND CREATING SPECIAL FUNDS AND ACCOUNTS FOR THE ADMINISTRATION OF FUNDS FOR OPERATION OF THE SYSTEM AND RETIREMENT OF THE REVENUE BOND AND PROVIDING FOR A SEGREGATED SPECIAL CHARGE OR SURCHARGE FOR THE PAYMENT OF THE BONDS.

WHEREAS, one of the purposes of SDCL Chapter 9-40 (the “Act”) as found and determined by the Legislature is to provide for financing the acquisition, maintenance, operation, extension or improvement of any system or part of any system for the collection, treatment and disposal of sewage and other domestic, commercial and industrial wastes; or any system for the control of floods and drainage; or any combination thereof, together with extensions, additions, and necessary appurtenances; and,

WHEREAS, a municipality is authorized by Section 6 of the Act to issue revenue bonds to defray the cost of extensions, additions and improvements to any utility previously owned without pledging its credit and is authorized to pledge the net income or revenues from the Project in accordance with Section 15 of the Act; and,

WHEREAS, the City of Aberdeen (the “City”) currently operates a sewer system for the collection, treatment and disposal of sewage and other domestic, commercial and industrial wastes; and for the control of floods and drainage and has determined that improvements to the sewer facilities are necessary for the conduct of its governmental programs and qualifies as an improvement, extension or addition to its sewer system; and,

WHEREAS, the City has determined to issue its revenue bonds to finance the improvements to its sewer system for the purpose of collecting, treating and disposing of sewage and other domestic, commercial and industrial wastes (the “System”) and has applied

to the South Dakota Conservancy District (the “District”) for a Clean Water State Revolving Fund Loan to finance the improvements;

WHEREAS, the City shall adopt special rates or surcharges for the improvements to be pledged, segregated and used for the payment of the Bonds.

NOW THEREFORE BE IT RESOLVED by the City as follows:

SECTION 1. Definitions. The terms when used in this Ordinance shall have the following meanings set forth in this section unless the context clearly requires otherwise. All terms used in this Ordinance which are not defined herein shall have the meanings assigned to them in the Loan Agreement unless the context clearly otherwise requires.

“**Act**” means South Dakota Codified Laws Chapter 9-40.

“**Loan**” means the Loan made by the South Dakota Conservancy District to the City pursuant to the terms of the Loan Agreement and as evidenced by the Revenue Bond.

“**Project**” means the City of Aberdeen Wastewater Treatment Facility Funding Improvements Application #2.

“**Revenue Bond**” means the revenue bond or bonds issued the date of the Loan Agreement by the City to the South Dakota Conservancy District to evidence the City’s obligation to repay the principal of and pay interest and Administrative Expense Surcharge on the Loan.

“**System**” means the City’s system of collecting, treating, and disposing of sewage and other domestic, commercial, and industrial wastes.

SECTION 2. Declaration of Necessity and Findings.

2.1.1. Declaration of Necessity. The City hereby determines and declares it is necessary to construct and finance improvements to its System described as the Project.

2.2. Findings. The City does hereby find as follows:

2.2.1. The City hereby expressly finds that if the Project is not undertaken, the System will pose a health hazard to the City and its inhabitants and will make the City unable to comply with state and federal law.

2.2.2. Because of the functional interdependence of the various portions of the System, the fact that the System may not lawfully operate unless it complies

with State and federal laws, including SDCL Chapter 34A-2, and the federal Clean Water Act, and the nature of the improvements financed, the City hereby finds and determines that the Project will substantially benefit the entire System and all of its users within the meaning of Sections 15 and 17 of the Act.

2.2.3. The City hereby determines and finds that for the purposes of the Act, including, in particular, Sections 15 and 17 of the Act, only the net income from the Project financed by the Revenue Bond be pledged for its payment.

SECTION 3. Authorization of Loan, Pledge of Revenue and Security.

3.1. Authorization of Loan. The City hereby determines and declares it necessary to finance up to \$30,000,000 of the costs of the Project through the issuance of bonds payable from the revenue of the Project and other funds secured by the City. The City hereby determines that because the Revenue Bond is issued in connection with a financing agreement described in SDCL 46A-1-49, pursuant to Section 15 of the Act no election is required to issue the Revenue Bond.

3.2. Approval of Loan Agreement. The execution and delivery of the Revenue Obligation Loan Agreement (the “Loan Agreement”), the form of which is on file with the Finance Officer (the “Finance Officer”) and open to public inspection, between the City as Borrower and the District, is hereby in all respects authorized, approved and confirmed, and the Mayor and Finance Officer are hereby authorized and directed to execute and deliver the Loan Agreement in the form and content attached hereto, with such changes as the Attorney for the City deems appropriate and approves, for and on behalf of the City. The Mayor and Finance Officer are hereby further authorized and directed to implement and perform the covenants and obligations of the City set forth in or required by the Loan Agreement. The Loan Agreement herein referred to and made a part of this Ordinance is on file in the office of the Finance Officer and is available for inspection by any interested party.

3.3. Approval of Revenue Bond. The issuance of a revenue bond in a principal amount not to exceed \$30,000,000 as determined according to the Loan Agreement in the form and content set forth in Appendix B attached to the form of Loan Agreement (the “Revenue Bond”) shall be and the same is, in all respects, hereby authorized, approved, and confirmed and the Mayor, Finance Officer, and other appropriate officials shall be and are hereby authorized and directed to execute and seal the Revenue Bond and deliver the Revenue Bond to the District, for and on behalf of the City, upon receipt of the purchase price, and to use the proceeds thereof in the manner set forth in the Loan Agreement. The Mayor and Finance Officer are hereby authorized to approve the final terms of the Revenue Bond and their

execution and delivery thereof shall evidence that approval. The Revenue Bond shall be issued under the authority of SDCL Chapter 9-40 and SDCL Chapter 6-8B, and the provisions of the Act are hereby expressly incorporated herein as provided in Section 19 of the Act.

3.4. Pledge of Revenues. The Revenue Bond together with the interest thereon, shall not constitute a charge against the City's general credit or taxing power, but shall be a limited obligation of the City payable solely out of the Project Debt Service Account, which payments, revenues and receipts are hereby and in the Loan Agreement pledged and assigned for the equal and ratable payments of the Revenue Bond and shall be used for no other purpose than to pay the principal of, interest and Administrative Surcharge on the Revenue Bond, except as may be otherwise expressly authorized in the Loan Agreement (including the purpose of securing Additional Bonds issued as permitted by the terms thereof). The City covenants and agrees to charge rates for all services from the Project or establish special charges or surcharges which will be sufficient to provide for the payments upon the Revenue Bond issued hereunder as and when the same become due, and as may be necessary to provide for the operation and maintenance and repairs of the Project, and depreciation, and the Rate Ordinance shall be revised from time to time so as to produce these amounts. The City hereby reserves the right to determine on a periodic basis the appropriate allocation of operation and maintenance expenses, depreciation, repair and reserves associated with the facilities financed with the Revenue Bond, provided that such determination of allocable operation and maintenance expenses shall in no event abrogate, abridge or otherwise contravene the covenant of the City set forth in this Section 3 or any other covenant or agreement in the Loan Agreement.

SECTION 4. Special Charge or Surcharge for Revenue Bond.

4.1. The City does hereby create the Revenue Bond Special-Surcharge District (the "Surcharge District") which shall include all users which benefit from the Project. There shall be charged a special charge or surcharge pursuant to Section 15 of the Act for the services provided by Project financed by the Revenue Bond. The special charge or surcharge shall be segregated from other revenues of the System and shall be used for the payment of the Revenue Bond. The special charge or surcharge shall create net income, remaining from time to time after first paying all reasonable and current expenses of maintenance, repairs, replacements, and operation, sufficient to fund interest, reserve and debt service fund annual requirements and shall be 110% of the debt service requirements on the Revenue Bond.

4.2. Rates and collection. The rate herein specific will be collected as a special charge or surcharge for the Project. This special charge or surcharge shall remain in effect until such time as the Revenue Bond is defeased or paid in full.

4.3. Initial Surcharge. The initial special charge or surcharge shall be set by ordinance and collected at the same time as other charges of the utility. All users within the Surcharge District which benefit from the Project, current and future, shall be charged the special charge or surcharge. The special charge or surcharge is found to be equitable for the services provided by the Project. The special charge or surcharge shall begin at such time as will produce sufficient revenue to pay principal of, interest and Administrative Surcharge on the Revenue Bond when due.

4.4. Segregation. The Finance Officer shall set up bookkeeping accounts in accordance with South Dakota Legislative Audit guidelines for the segregation of the revenue, special charges, and surcharges.

4.5. Periodic review. The amount of the surcharge shall be reviewed from time to time, not less than yearly, and shall be modified in order to produce such funds as are necessary and required to comply with the Loan Agreement's rate covenant and to pay principal of, interest and Administrative Surcharge on the Revenue Bond when due. The surcharge may be set by ordinance in accordance with this Section. The rate ordinance shall be necessary for the support of government and shall be effective upon passage.

SECTION 5. Additional Bonds. As permitted by Sections 8 and 9 of the Act, Additional Bonds payable from revenues and income of the System or Project may be issued, as permitted in the Loan Agreement, and no provision of this Ordinance shall have the effect of restricting the issuance of, or impairing the lien of, such additional parity bonds with respect to the net revenues or income from the extensions, additions or improvements. The City shall have the right to issue additional bonds secured by a lien subordinate to the lien from the Revenue Bond pursuant to the Loan Agreement.

SECTION 6. Project Fund Accounts. For the purpose of application and proper allocation of the income of the Project and to secure the payment of principal, Administrative Surcharge and interest on the Revenue Bond, the following mandatory asset segregations shall be included in the sewer system account of the City and shall be used solely for the following respective purposes until payment in full of the principal of and interest on the Revenue Bond:

6.1. Project Revenue Account. There shall be deposited periodically into the Project Revenue Account the net revenues as defined in Section 17 of the Act derived from the operation of the Project collected pursuant to the resolutions and

ordinances of the City of Aberdeen, South Dakota (collectively the “Rate Ordinance”). Moneys from the Project Revenue Account shall be transferred periodically into separate funds and accounts as provided below.

6.2. Project Debt Service Account. Out of the revenues in the Project Revenue Account, there shall be set aside no later than the 25th day of each month into the account designated Project Debt Service Account, a sum sufficient to provide for the payment as the same become due of the next maturing principal of, interest and Administrative Surcharge on the Revenue Bonds and any reserve determined by the City’s governing body to be necessary. The amount set aside monthly shall be not less than one-third of the total principal, interest, and Administrative Surcharge payable on the following February 15, May 15, August 15 or November 15 and if there shall be any deficiency in the amount previously set aside, then the amount of such deficiency shall be added to the current requirement.

6.3. Depreciation Account. There shall be established a General Depreciation Account. Out of the revenues of the Project Revenue Account there shall be set aside each month into the General Depreciation Account an amount determined by the Common Council to be a proper and adequate amount for repair and depreciation of the Project.

6.4. Project Surplus Account. There shall be established the Project Surplus Account. Revenues remaining in the Project Revenue Account at the end of any fiscal year after all periodic transfers have been made therefrom as above required, shall be deemed to be surplus and shall be transferred to the Project Surplus Account. If at any time there shall exist any default in making any periodic transfer to the Project Debt Service Account, the Common Council shall authorize the Finance Officer to rectify such default so far as possible by the transfer of money from the Project Surplus Account. If any such default shall exist as to more than one account or fund at any time, then such transfer shall be made in the order such funds and accounts are listed above.

When not required to restore a current deficiency in the Project Debt Service Account, moneys in the Project Surplus Account from time to time may be used for any of the following purposes and not otherwise:

- (a) To redeem and prepay the Revenue Bond when and as such Revenue Bond becomes prepayable according to its terms;
- (b) To pay for repairs of or for the construction and installation of improvements or additions to the System; and, if the balances in the Project Debt Service Account and the Project Depreciation Account are sufficient to

meet all payments required or reasonably anticipated to be made there from prior to the end of the then current fiscal year, then:

(c) To be held as a reserve for redemption and prepayment of any bonds of the System which are not then but will later be prepayable according to their terms; or

(d) To be used for any other authorized municipal purpose designated by the Common Council.

(e) No moneys shall at any time be transferred from the Project Surplus Account or any other account of the Fund to any other fund of the City, nor shall such moneys at any time be loaned to other municipal funds or invested in warrants, special improvements bonds or other obligations payable from other funds, except as provided in this Section.

SECTION 7. Approval of Paying Agent/Registrar. The Revenue Bond shall be payable at the office of U.S. Bank National Association, St. Paul, Minnesota, hereby designated as paying agent and registrar.

SECTION 8. Approval of Bond Counsel. Meierhenry Sargent LLP is hereby retained as Bond Counsel with respect to the Revenue Bond.

SECTION 9. Tax Matters. The Interest on the Revenue Bond shall be excludable from gross income for federal income tax purposes under the Internal Revenue Code of 1986, as amended (“the Code”) and applicable Treasury Regulations (the “Regulations”).

SECTION 10. Covenants. The City hereby covenants and agrees with the District and other owners of the Revenue Bond as follows:

10.1. The City will punctually perform all duties with reference to the Project, the System and the Revenue Bond required by the constitution and laws of the State of South Dakota and by this Ordinance.

10.2. The City agrees and covenants that it will promptly construct the improvements included in the Project.

10.3. The City covenants and agrees that pursuant to Sections 25 through 27 of the Act, the lawful holders of the Revenue Bond shall have a statutory mortgage lien upon the Project and the extensions, additions and improvements thereto acquired pursuant to the Act, until the payment in full of the principal and interest on the Revenue Bond, and the City agrees not to sell or otherwise dispose of the System, the Project, or any substantial part

thereof, except as provided in the Loan Agreement and shall not establish, authorize or grant a franchise for the operation of any other utility supplying like products or services in competition therewith, or permit any person, firm or corporation to compete with it in the collection, treatment, and disposal of sewage and other domestic, commercial and industrial wastes for municipal, industrial, and domestic purposes within the City.

10.4. The City covenants and agrees with the District and other owners of the Revenue Bond that it will maintain the System in good condition and operate the same in an efficient manner and at a reasonable cost, so long as any portion of the Revenue Bond remains outstanding; that it will maintain insurance on the System for the benefit of the holders of the Revenue Bond in an amount which usually would be carried by private companies in a similar type of business; that it will prepare, keep and file records, statements and accounts as provided for in this Ordinance and the Loan Agreement. The Revenue Bond shall refer expressly to this Ordinance and the Act and shall state that it is subject to all provisions and limitations thereof pursuant to Section 19 of the Act.

SECTION 11. Depositories. The Finance Officer shall cause all moneys pertaining to the Funds and Accounts to be deposited as received with one or more banks which are duly qualified public depositories under the provisions of SDCL Ch. 4-6A, in a deposit account or accounts, which shall be maintained separate and apart from all other accounts of the City, so long as any of the Bonds and the interest thereon shall remain unpaid. Any of such moneys not necessary for immediate use may be deposited with such depository banks in savings or time deposits. No money shall at any time be withdrawn from such deposit accounts except for the purposes of the Funds and Accounts as authorized in this Ordinance; except that moneys from time to time on hand in the Funds and Accounts may at any time, in the discretion of the City's governing body, be invested in securities permitted by the provisions of SDCL 4-5-6; provided, however, that the Depreciation Fund may be invested in such securities maturing not later than ten years from the date of the investment. Income received from the deposit or investment of moneys shall be credited to the Fund or Account from whose moneys the deposit was made or the investment was purchased, and handled and accounted for in the same manner as other moneys therein.

SECTION 12. Consent to Appointment. In the event of mismanagement of the Project, a default in the payment of the principal or interest of the Revenue Bond, or in any other condition thereof materially affecting the lawful holder of the Revenue Bond, or if the revenues of the Project are dissipated, wasted or diverted from their proper application as set forth in the Loan Agreement, Revenue Bond, or herein, the City hereby consents to the appointment of a receiver pursuant to Section 33 of the Act, and agrees that the receiver

will have the powers set forth therein, and in Sections 34 and 35 of the Act to operate and administer the Project, and charge and collect rates as described therein.

SECTION 13. Severability. If any section, paragraph, clause or provision of this Ordinance, the Loan Agreement, the Revenue Bond, or any other Loan Document shall be held invalid, the invalidity of such section, paragraph, clause or provision shall not affect any of the other provisions of this Ordinance or said Loan Agreement, Revenue Bond, or any other Loan Document.

SECTION 14. Repeal of Ordinance. At such time as the Revenue Bond is defeased or paid in full, this Ordinance and the special charge or surcharge shall automatically be repealed without any further action of the City.

SECTION 15. Authorization of City Officials. The Mayor, Finance Officer, City Attorney and City officials shall be and they are hereby authorized to execute and deliver for and on behalf of the City any and all other certificates, documents or other papers and to perform such other acts as they may deem necessary or appropriate in order to implement and carry out the actions authorized herein.

SECTION 16. Effective Date. This Ordinance shall take effect on the 20th day following its publication, unless suspended by a referendum.

Adopted at Aberdeen, South Dakota, this _____ day of _____, 2026.

ATTEST:

Travis Schaunaman, Mayor

Jordan McQuillen, Finance Officer (SEAL)

First Reading: _____

Second Reading: _____

Adopted: _____

Published: _____

Effective Date: _____



City of Aberdeen

Council Agenda Memo

Agenda Item **6D**

Meeting Date:	2/23/2026	Department:	Finance
Agenda Section:	Old Business	Presented by:	Jordan McQuillen City Finance Officer
Res./Ord. Number:	Ord. 26-02-10	Attachments:	1

Agenda Item Title:

Possible approval of Second Reading and Final Adoption of Ordinance No. 26-02-10 establishing a sewer surcharge for CW-05 SRF debt service

Proposed or Possible Action:

Motion and second to approve second reading and final adoption of Ordinance No. 26-02-10 establishing a sewer surcharge for CW-05 SRF debt service

Overview:

This ordinance amends the City’s sewer rate structure to establish a dedicated monthly surcharge to fund debt service associated with the CW-05 Clean Water State Revolving Fund loan. The surcharge is required under the loan agreement to ensure sufficient revenues are generated to meet principal, interest, administrative surcharge, and reserve requirements on the associated borrower bond.

The ordinance sets a system-wide surcharge applicable to all sewer customers who benefit from the financed improvements. The surcharge revenues are required to be segregated from other system revenues and pledged solely for repayment of the CW-05 borrower bond.

Surcharge Details:

- **CW-05 Sewer Surcharge:** \$16.05 per user per month
- **Effective Billing Date:** December 1, 2027
- **Duration:** Remains in effect until the CW-05 borrower bond is paid in full

The surcharge will be reviewed annually and may be adjusted, upward or downward, as necessary to meet required debt service and coverage obligations.

There have been no changes to the ordinance since first reading on February 17, 2026.

Financial Consideration:

This ordinance establishes a dedicated revenue source for repayment of the CW-05 Clean Water SRF loan. The surcharge is structured to meet debt service requirements assuming a 10% delinquency rate and does not impact the City’s General Fund or property tax levy.

Attachments:

1. Ordinance 26-02-10

First Reading: _____
Second Reading: _____
Adopted: _____
Published: _____
Effective Date: _____

ORDINANCE NO 26-02-10

ORDINANCE AMENDING THE CITY’S RATE STRUCTURE, PROVIDING FOR A SURCHARGE FOR IMPROVEMENTS TO THE SEWER SYSTEM, FOR PAYMENT OF A REVENUE BORROWER BOND AND YEARLY REVIEW OF RATE

BE IT ORDAINED BY THE CITY COUNCIL OF THE CITY OF ABERDEEN AS FOLLOWS:

1. **Surcharge for Borrower Bond.** There shall be charged a monthly surcharge for the services provided by the improvement financed by the CW-05 Conservancy District Loan. The surcharge for each loan shall be segregated from other revenues of the City and shall be used for the payment of the Borrower Bond CW-05 (the “Borrower Bond”). Provided that such surcharge shall create net income, remaining from time to time after first paying all reasonable and current expenses of maintenance, repairs, replacements, and operation, sufficient to fund interest, reserve, and debt service fund annual requirements.

2. **Rates and collection.** The City does hereby establish the special charge or surcharge payable by each customer of its system who receives or benefits from the services of the project financed with the Borrower Bond. Such charge or surcharge shall be set at a level which, assuming a 10% delinquency rate, will produce income at the times and in amounts sufficient to pay when due the principal of and interest on the Borrower Bond and the administrative expense surcharge and all other payments as may be required under the loan agreement and Borrower Bond.

3. **Borrower Bond Surcharge.** The following clean water debt service surcharge shall be applicable to all customers served:

Borrower Bond CW-05 Surcharge: \$16.05 per user per month commencing December 1, 2027.

This surcharge shall remain in effect until such time as the revenue bond is paid in full. The initial surcharge shall be collected at the same time as other charges of the system. The surcharge is found to be equitable for the services provided by the improvements.

4. **Segregation.** The debt service surcharge shall be segregated from other income of the system in a separate book-keeping account and is pledged to the South Dakota Conservancy District for the payment of the loan payments on the Borrower Bond.

5. **Yearly review.** The amount of the surcharge shall be reviewed from year to year and may be modified in order to provide such funds as are set forth herein. The charges shall be reviewed yearly by City and administratively adjusted, upwards or downwards, to such amounts as may be necessary to pay principal, interest, administrative surcharge, and other charges as may become due and owing under the loan agreement or Borrower Bond.

6. **Billing and Accounting.** The surcharges shall be included in the monthly user bill. Nothing contained herein requires the surcharge be indicated on the billing, however, the surcharge segregation shall be indicated on the books of the City.

7. **Automatic Repeal.** The surcharge for the Borrower Bond shall be automatically repealed when the Borrower Bond is paid in full.

8. **Partial Invalidity.** If any one or more of the provisions of the shall be held invalid, illegal, or unenforceable in any respect, by final decree of any court of lawful jurisdiction, such invalidity, illegality, or unenforceability shall not affect any other provision hereof.

9. **Effective Date.** The City Finance Officer shall cause this Ordinance to be published in the official newspaper. This Ordinance shall become effective twenty (20) days after the completed publication, unless the referendum is invoked.

Adopted at Aberdeen, South Dakota, this _____ day of _____, 2026.

ATTEST:

Travis Schaunaman, Mayor

Jordan McQuillen, Finance Officer (SEAL)

First Reading: _____

Second Reading: _____

Adopted: _____

Published: _____

Effective Date: _____



City of Aberdeen

Council Agenda Memo

Agenda Item 7A

Meeting Date:	2/23/2026	Department:	Finance
Agenda Section:	New Business	Presented by:	Finance
Res./Ord. Number:	NA	Attachments:	3

Agenda Item Title:

Public Hearing on a request for a Special One-Day, On-Sale, Liquor License for Boys & Girls Club of Aberdeen, Winefest 2026, March 28, 2026, 1123 N Lincoln St

Proposed or Possible Action:

Motion and second to approve the Special One-Day, On-Sale, Liquor License for Boys & Girls Club of Aberdeen, Winefest 2026, March 28, 2026, 1123 N Lincoln St

Overview:

The [Organization name] submitted an application for a Special One-Day, On-Sale, Liquor License for Boys & Girls Club of Aberdeen, Winefest 2026, March 28, 2026, 1123 N Lincoln St. A Notice of Hearing on the special one-day license was published in the Aberdeen Insider on 02/05/2026, as required by SDCL. The Police Department performed a background check on the applicant, and the Health and Fire Departments completed their inspections on the locations.

Financial Consideration:

NA

Attachments:

1. Special Alcoholic Beverage License – Special Event
2. Department Recommendation Form
3. Insurance Information



Special Alcoholic Beverage License – Special Event
City of Aberdeen Finance Office

123 South Lincoln Street
 Aberdeen, SD 57401 | PH: (605) 626-7023
 Email: records@aberndeen.sd.us

The Special Alcoholic Beverage License – Special Event application fees are \$30.00 per event and a \$20.00 per publication fee (\$50.00 total). A Consent to Background Check Form must be completed and submitted with this form.

Applicants must be a civic, charitable, education, fraternal, or veterans organization or any licensee licensed pursuant to SDCL § 35-4-124 Special alcoholic beverage licenses – Special events – Duration – Hearing-Local government rules required. See also Resolution No. 12-10-01R for rules regarding special alcoholic beverage licenses.

Section 1: Applicant Information			
Are you a civic, charitable, education, fraternal, veterans or current alcohol license holder?			<input checked="" type="checkbox"/> Yes <input type="checkbox"/> No
If you are a current alcohol license holder, please provide a copy of your current license with the application.			
Business Name:	Boys & Girls Club of Aberdeen	DBA:	
Address:	1123 N. Lincoln Street	City, State, Zip:	Aberdeen, SD 57401
Phone Number:	[REDACTED]	Email:	[REDACTED]
Contact Person Name:	Bryan Kriech	Phone Number:	[REDACTED]

Section 2: Event Information					
Event Type (chose only one):		<input checked="" type="checkbox"/> Community Event	<input type="checkbox"/> Parks & Rec Facility	<input type="checkbox"/> Private Property	
Event Address:	1121 1st Avenue Se	City, State, Zip:	Aberdeen, SD 57401		
Event Date(s):	March 28, 2026	Start Time:	4:30 PM	End Time:	8:30 PM
Name of Event:	Indicate the class of license being applied for:	<input checked="" type="checkbox"/> Liquor (On Sale)	<input type="checkbox"/> Beer (On Sale)	<input type="checkbox"/> Wine (On Sale)	<input type="checkbox"/> Cider (On Sale)
Winefest 2026		<input checked="" type="checkbox"/> Liquor (No Sale)	<input type="checkbox"/> Beer (No Sale)	<input type="checkbox"/> Wine (No Sale)	<input type="checkbox"/> Cider (No Sale)

Section 3: Acknowledgement
 The undersigned applicant certifies under the penalties of perjury that all statements provided herein are correct; that the said applicant complies with all of the statutory requirements for the class of license being applied in SDCL § 35-4-124 and agrees this application shall constitute a contract between the applicant and the City of Aberdeen entitling the same or any peace officer to inspect the event and location referenced above for the purposes of Title 35 SDCL, as amended.

01/19/2026

 Date

 Signature
 Bryan Kriech

 Print Name
 Director of Development

 Title

Office Use Only			
Consent Date:	2/2/26	Publication Date:	2/5/26
		Public Hearing Date:	2/23/26
Public hearing cannot be less than seven (7) days after official publication			
City Council Recommendation:	<input type="checkbox"/> Approve	<input type="checkbox"/> Deny (List reason below)	<input type="checkbox"/> Other (List reason below)

_____ Date

_____ Mayor

[SEAL]



DEPARTMENTS' RECOMMENDATION FORM
ALCOHOL BEVERAGE/LOTTERY LICENSE
APPLICATIONS
Internal Use Only

SPECIAL
ONE-DAY

02/03/2026

Applicant Information: Boys & Girls Club of Aberdeen
 1123 N. Lincoln St

TYPE OF LICENSE	NEW	RENEW	TRANSFER
RETAIL LIQUOR/RESTAURANT LIQUOR			
PACKAGE OFF-SALE LIQUOR			
RETAIL ON-OFF SALE WINE			
RETAIL ON-OFF SALE MALT BEVERAGE			
SPECIAL ONE-DAY RETAIL LIQUOR	X		
VIDEO LOTTERY			

DEPARTMENT RECOMMENDATION

Police Department

Comments:
Spillman / E-Courts show no concern -

- Approved
 Disapprove

Date: 2-5-26

By: Capt. Tony Bider

Fire Department

Comments:

- Approved
 Disapprove

Number of Video Lottery Machines: _____ Verified: _____

Date: 2/6/25

By: _____

Community Dev.

Comments:

- Approved
 Disapprove

Date: 2/9/25

By: An Kallala

Finance Dept.

Comments:
Fees PIF

- Approved
 Disapprove

Video Lottery Eligible: Yes No
 Property Taxes Paid: Yes No
 Leased N/A

Date: 2/3/26

By: [Signature]



CERTIFICATE OF LIABILITY INSURANCE

DATE (MM/DD/YYYY)

02/04/2026

THIS CERTIFICATE IS ISSUED AS A MATTER OF INFORMATION ONLY AND CONFERS NO RIGHTS UPON THE CERTIFICATE HOLDER. THIS CERTIFICATE DOES NOT AFFIRMATIVELY OR NEGATIVELY AMEND, EXTEND OR ALTER THE COVERAGE AFFORDED BY THE POLICIES BELOW. THIS CERTIFICATE OF INSURANCE DOES NOT CONSTITUTE A CONTRACT BETWEEN THE ISSUING INSURER(S), AUTHORIZED REPRESENTATIVE OR PRODUCER, AND THE CERTIFICATE HOLDER.

IMPORTANT: If the certificate holder is an ADDITIONAL INSURED, the policy(ies) must have ADDITIONAL INSURED provisions or be endorsed. If SUBROGATION IS WAIVED, subject to the terms and conditions of the policy, certain policies may require an endorsement. A statement on this certificate does not confer rights to the certificate holder in lieu of such endorsement(s).

PRODUCER Insurance Plus 405 NW 8th Avenue PO Box 1540 Aberdeen SD 57401		CONTACT NAME: Mary McGregor Heier PHONE (A/C, No, Ext): (605) 225-4270 E-MAIL ADDRESS: mary@ins-plus.com FAX (A/C, No): (605) 225-4217	
		INSURER(S) AFFORDING COVERAGE	
		INSURER A: Philadelphia Insurance Co	NAIC # 18058
		INSURER B: First Dakota Indemnity Company	
		INSURER C:	
		INSURER D:	
		INSURER E:	
		INSURER F:	
INSURED Boys & Girls of Aberdeen Area 1121 1st Ave SE Aberdeen SD 57401-4704			

COVERAGES

CERTIFICATE NUMBER: CL25111013013

REVISION NUMBER:

THIS IS TO CERTIFY THAT THE POLICIES OF INSURANCE LISTED BELOW HAVE BEEN ISSUED TO THE INSURED NAMED ABOVE FOR THE POLICY PERIOD INDICATED. NOTWITHSTANDING ANY REQUIREMENT, TERM OR CONDITION OF ANY CONTRACT OR OTHER DOCUMENT WITH RESPECT TO WHICH THIS CERTIFICATE MAY BE ISSUED OR MAY PERTAIN, THE INSURANCE AFFORDED BY THE POLICIES DESCRIBED HEREIN IS SUBJECT TO ALL THE TERMS, EXCLUSIONS AND CONDITIONS OF SUCH POLICIES. LIMITS SHOWN MAY HAVE BEEN REDUCED BY PAID CLAIMS.

INSR LTR	TYPE OF INSURANCE	ADDL INSD	SUBR WVD	POLICY NUMBER	POLICY EFF (MM/DD/YYYY)	POLICY EXP (MM/DD/YYYY)	LIMITS	
A	<input checked="" type="checkbox"/> COMMERCIAL GENERAL LIABILITY <input type="checkbox"/> CLAIMS-MADE <input checked="" type="checkbox"/> OCCUR GEN'L AGGREGATE LIMIT APPLIES PER: <input type="checkbox"/> POLICY <input type="checkbox"/> PRO-JECT <input type="checkbox"/> LOC OTHER:			PHPK2618522-016	11/02/2025	11/02/2026	EACH OCCURRENCE	\$ 1,000,000
							DAMAGE TO RENTED PREMISES (Ea occurrence)	\$ 100,000
							MED EXP (Any one person)	\$ 5,000
							PERSONAL & ADV INJURY	\$ 1,000,000
							GENERAL AGGREGATE	\$ 3,000,000
							PRODUCTS - COMP/OP AGG	\$ 3,000,000
							Cyber Terrorism	\$
A	<input checked="" type="checkbox"/> AUTOMOBILE LIABILITY <input checked="" type="checkbox"/> ANY AUTO <input type="checkbox"/> OWNED AUTOS ONLY <input type="checkbox"/> SCHEDULED AUTOS <input type="checkbox"/> HIRED AUTOS ONLY <input type="checkbox"/> NON-OWNED AUTOS ONLY			PHPK2618522-016	11/02/2025	11/02/2026	COMBINED SINGLE LIMIT (Ea accident)	\$ 1,000,000
							BODILY INJURY (Per person)	\$
							BODILY INJURY (Per accident)	\$
							PROPERTY DAMAGE (Per accident)	\$
							GOAOT	\$ 3,000,000
A	<input checked="" type="checkbox"/> UMBRELLA LIAB <input type="checkbox"/> EXCESS LIAB <input type="checkbox"/> OCCUR <input type="checkbox"/> CLAIMS-MADE <input type="checkbox"/> DED <input checked="" type="checkbox"/> RETENTION \$ 10,000			PHUB887234-016	11/02/2025	11/02/2026	EACH OCCURRENCE	\$ 1,000,000
							AGGREGATE	\$
								\$
B	WORKERS COMPENSATION AND EMPLOYERS' LIABILITY ANY PROPRIETOR/PARTNER/EXECUTIVE OFFICER/MEMBER EXCLUDED? (Mandatory in NH) If yes, describe under DESCRIPTION OF OPERATIONS below		N/A	WC02000069632025A	11/02/2025	11/02/2026	PER STATUTE	
							OTH-ER	
							E.L. EACH ACCIDENT	\$ 500,000
							E.L. DISEASE - EA EMPLOYEE	\$ 500,000
							E.L. DISEASE - POLICY LIMIT	\$ 500,000

DESCRIPTION OF OPERATIONS / LOCATIONS / VEHICLES (ACORD 101, Additional Remarks Schedule, may be attached if more space is required)

CERTIFICATE HOLDER**CANCELLATION**

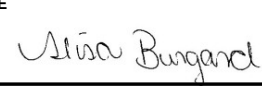
City of Aberdeen 123 South Lincoln Aberdeen SD 57401	SHOULD ANY OF THE ABOVE DESCRIBED POLICIES BE CANCELLED BEFORE THE EXPIRATION DATE THEREOF, NOTICE WILL BE DELIVERED IN ACCORDANCE WITH THE POLICY PROVISIONS. AUTHORIZED REPRESENTATIVE 
--	--

© 1988-2015 ACORD CORPORATION. All rights reserved.



City of Aberdeen

Council Agenda Memo

Agenda Item **7B**

Meeting Date:	2/23/2026	Department:	Finance
Agenda Section:	New Business	Presented by:	Finance Office
Res./Ord. Number:	NA	Attachments:	4

Agenda Item Title:

Public Hearing and possible approval of the transfer of Retail On-Off Sale Malt Beverage and SD Farm Wine License RB-27440 from Walar Inc. dba Palm Garden Thai Cuisine, 602 S 3rd St to Myint Tun Aung dba Palm Garden Thai Cuisine, 602 S 3rd St

Proposed or Possible Action:

Motion and second to to approve of the transfer of Retail On-Off Sale Malt Beverage and SD Farm Wine License RB-27440 from Walar Inc. dba Palm Garden Thai Cuisine, 602 S 3rd St to Myint Tun Aung dba Palm Garden Thai Cuisine, 602 S 3rd St

Overview:

Myint Tun Aung dba Palm Garden Thai Cuisine submitted an application to transfer the Retail On-Off Sale Malt Beverage and SD Farm Wine License RB-27440. A Notice of Hearing on the license transfer request was published in the Aberdeen Insider on February 12, 2026 as required by SDCL. The APD performed a background check on the applicant, the AFD and Community Development completed inspection at the proposed location.

Financial Consideration:

None

Attachments:

1. Applications for Alcoholic Beverage Licenses
2. Affidavit of Transfer
3. Departments' Recommendation Form
4. Active Alcohol License

Date Received: _____
Date Issued: _____

Uniform Alcoholic Beverage License Application

License No. 8B-27440

A. CORPORATION, LLC OR SOLE PROPRIETOR NAME AND MAILING ADDRESS

Name <u>MYINT TUN ALUNG</u>		Phone Number <u>(605) 216-4286</u>	
Address <u>1007 S State St Apt 104</u>	City <u>Aberdeen</u>	State <u>SD</u>	Zip <u>57401</u>

B. DOING BUSINESS AS NAME AND PHYSICAL ADDRESS

Name <u>Palm Garden Thai Cuisine</u>		Phone Number <u>(605) 262-0238</u>	
Address <u>602 S 3rd St, A</u>	City <u>Aberdeen</u>	State <u>SD</u>	Zip <u>57401</u>

C. INDICATE CLASS OF LICENSE BEING APPLIED FOR
(Submit separate application for each class of license).

- Retail (on-sale) Liquor
- Retail (on-off sale) Malt Beverage & SD Farm Wine
- Retail (on-sale) Liquor - Restaurant
- Package Delivery
- Convention Center (on-sale) Liquor
- Hunting Preserve
- Package (off-sale) Liquor
- Other
- Retail (on-off sale) Wine and Cider

Is this license in active use?	<input checked="" type="checkbox"/> YES [] NO
Do you or any officers, directors, partners, or stockholders hold any other alcohol retail, manufacturing, or wholesaler licenses? (If yes, please list on additional sheet)	[] YES <input checked="" type="checkbox"/> NO

Is place of business located in a municipality?	<input checked="" type="checkbox"/> YES [] NO
County	<u>Brown</u>
Do you own or lease this property?	[] OWN <input checked="" type="checkbox"/> LEASE
Are real property taxes paid to date?	<input checked="" type="checkbox"/> YES [] NO
Are you of good moral character having never been convicted of a felony?	<input checked="" type="checkbox"/> YES [] NO

D. LEGAL DESCRIPTION OF LICENSED PREMISE:

Legal Description: Palm Garden Addition, Lot 1, Aberdeen, Brown County

- E. State Sales Tax Number [REDACTED]
- F. [] New License Transfer? (\$150) [] Re-issuance

G. CERTIFICATE: The undersigned applicant certifies under the penalties of perjury that all statements provided herein are correct; that the said applicant complies with all of the statutory requirements for the class of license being applied in SDCL 35-2-2.1 and agrees this application shall constitute a contract between applicant and the State of South Dakota entitling the same or any peace officers to inspect the premises, books and records at any time for the purpose of enforcing the provisions of Title 35 SDCL, as amended.

Date <u>02/06/2026</u>	Print Name <u>MYINT TUN ALUNG</u>	Signature <u>[Signature]</u>
---------------------------	--------------------------------------	---------------------------------

H. APPROVAL OF LOCAL GOVERNING BODY Notice of hearing was published on 2/12/26. Public hearing on the application was held 2/23/26, not less than SEVEN (7) days after official publication. The governing body by majority vote recommends the approval and granting of this license and certifies that requirements as to location and suitability of premises and applicant have been reviewed and conform to the requirements of local and South Dakota law.

FOR LOCAL GOVERNMENT USE

(Seal) Mayor or Chairman	Date

Renewal—no public hearing held: []
Establishment is ineligible for video lottery:
Amount of fee collected with application: \$ 150.00
Amount of fee retained: \$ 75.00
Forwarded with application: \$ 75.00

If disapproved, endorse reason thereon and return to applicant

**Uniform Alcoholic Beverage License Application
(For corporate/partnership/LP/LLC applicants)**

Name of corporation/partnership/LP/LLC <p align="center">ALING Family LLC</p>		
Address of office and principal place of business of corporation/partnership/LP/LLC <p align="center">602 S 3rd St A</p>		
City <p align="center">Aberdeen</p>	State <p align="center">SD</p>	Zip Code <p align="center">57401</p>
Are all managing officers of this corporation/partnership/LP/LLC of good moral character having never been convicted of a felony?		<input checked="" type="checkbox"/> YES [] NO

Name, title of office, occupation, and address of each of the officers/owners of the corporation, partnership, LP or LLC:

Name	Office	Address	Occupation
MYINT FUN ALING		[REDACTED]	

Name of any officers, directors, partners, or stockholders of applicant having a financial interest or capital stock in any other alcoholic beverage license:

Name	Type of License	License #	Financial Interest Held	Address of Business Location

Where and with whom are all company records kept, such as charter, by-laws, minutes, accounts, notes payable, and notes and accounts receivable, etc.?

602 S 3rd St Aberdeen SD 57401

With signature the applicant agrees to the following:

That the applicant company will comply with all provisions of ARSD chapter No. 64:75:02 of the Department of Revenue, relating to the transfer of stock and prior approval of the transfer of such stock by the Secretary of Revenue and violation of any of the provisions of said regulation or failure to comply therewith, whether by the undersigned corporation, partnership/LP/LLC or by any stockholder thereof, or by anyone interested in said company, shall constitute cause for revocation or suspension of any license issued pursuant to and in reliance on this application, or for refusal to renew such license upon expiration thereof.

We the undersigned officers and directors of the applicant company acknowledge that the within supplement application form is true and correct in every respect and that there exists no financial arrangement concerning this or any other alcoholic beverage license that that expressly set forth above. If company stock is to be transferred we ask for approval of such voluntary stock transfer.

Signature of Authorized Officer/Director/Partner 	Date <p align="center">02/06/2026</p>
--	--

AFFIDAVIT

STATE OF South Dakota)
)ss
COUNTY OF Brown)

Walar Inc., being first duly sworn on oath deposes and says: That on the 6th day of February, 2026 he/she was the owner of the license/business/stock of RB-27440 situated on (legal description) Palm Garden Add. Lot 1 in the city/county of Aberdeen, Brown Co., South Dakota and that on the said date he/she made a transfer/sale of said license operated under an alcoholic beverage license to:

Myint Tun Aung of Aberdeen, SD.
607 S. State St
Aberdeen SD 57401

[Handwritten signature]

(owner/seller)

(owner/seller)

Subscribed and sworn to before me this 6th day of February, 2026.

[Handwritten signature]

(notary public)

Commission Expires: 1/2/30

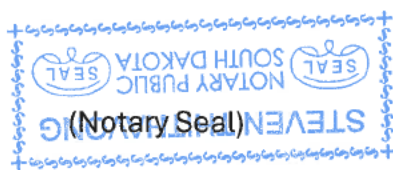



DEPARTMENTS' RECOMMENDATION FORM
ALCOHOL BEVERAGE/LOTTERY LICENSE
APPLICATIONS
Internal Use Only

TRANSFER
RB-27440

02/12/2026

Applicant Information: Palm Garden Thai Cuisine
602 S 3rd St

TYPE OF LICENSE	NEW	RENEW	TRANSFER
RETAIL LIQUOR/RESTAURANT LIQUOR			
PACKAGE OFF-SALE LIQUOR			
RETAIL ON-OFF SALE WINE			
RETAIL ON-OFF SALE MALT BEVERAGE			X
SPECIAL ONE-DAY RETAIL LIQUOR			
VIDEO LOTTERY			

DEPARTMENT RECOMMENDATION

Police Department

Approved
 Disapprove

Date: 2-13-26 By: Capt. Tony Bisbee

Comments:

Fire Department

Approved
 Disapprove

Date: 2/17/26 By: _____

Number of Video Lottery Machines: 0 Verified:

Comments:

Community Dev.

Approved
 Disapprove

Date: 2/17/26 By: _____

Comments:

Finance Dept.

Approved
 Disapprove

Date: 2/12/26 By: _____

Comments:
Transfer fees PIF

Video Lottery Eligible: Yes No
Property Taxes Paid: Yes No Leased NA

WALAR INC
PALM GARDEN THAI CUISINE
602 S 3RD ST
ABERDEEN, SD 57401-5903

June 17, 2025

Dear WALAR INC

Below is your Retail On and Off Sale Malt Beverage license. It shall be valid only for the person in whose name it is issued and for the transaction of business at the location approved. The license shall be available for inspection.

A list of the approved alcohol training programs may be found at: <https://dor.sd.gov/businesses/taxes/alcohol/>

Website: <http://dor.sd.gov>

SD EPath: <http://dor.sd.gov/EPath>



This license is issued to the below named. This license remains the property of the State of South Dakota and, while in possession of the person to whom issued, entitles the licensee to transact the business or activity specified on this license until this license expires or is cancelled. This license makes no representation about the legality of products or services sold.

<http://dor.sd.gov>

ISSUE DATE: 07/01/2025

EXPIRATION DATE: 06/30/2026

LICENSE NUMBER: RB-27440

LICENSE TYPE: Retail On and Off Sale Malt Beverage

ISSUED TO:

WALAR INC
602 S 3RD ST
ABERDEEN, SD 57401-5903

PALM GARDEN THAI CUISINE

602 S 3RD ST

ABERDEEN, SD 57401-5903

A handwritten signature in black ink, appearing to read 'Mike Houdyshell', is written over a light blue background.

Mike Houdyshell
Secretary of Revenue



Meeting Date:	2/23/2026	Department:	City Engineer
Agenda Section:	New Business	Presented by:	City Engineer City Manager
Res./Ord. Number:	26-02-02R	Attachments:	2

Agenda Item Title:

Possible first reading and passage of Resolution No. 26-02-02R accepting dedication of certain public improvements in Dakota Estates Subdivision.

Proposed or Possible Action:

Motion by _____ second by _____ to approve first reading of Resolution No. 26-02-02R accepting dedication of certain public improvements in Dakota Estates Third Subdivision, legally described as Lots 6A, 7B, 7C and 8A in Block 2 of Dakota Estates Third Subdivision in the Southwest Quarter (SW1/4) of Section 6, Township 123 North, Range 63 West of the 5th P.M., Brown County, South Dakota, plat recorded December 28, 2021 as Plat No. 3783 (Parcel IDs 31283, 31285, 31386, and 31387), from the developers Purple Cow Properties, LLC, Forte of Aberdeen, LLC, and Dakota Estates III, LLC.

Overview:

The intent of the resolution is to transfer to the City certain public improvements located in the Dakota Estates Third Subdivision, constructed by the developers, Purple Cow Properties, LLC, Forte of Aberdeen, LLC, and Dakota Estates III, LLC, as supported by Tax Increment Financing District No. 35. The public improvements are identified as the water system, sanitary sewer system, storm sewer, streets, curb and gutter, and sidewalks in the public rights-of-way. Acceptance by the Council of the dedicated public improvements conveys such improvements to the City and obligates the City to assume the future operation and maintenance of the improvements for public use, except sidewalks, the repair and maintenance of which are obligations of the abutting lot owner. The City Engineer has determined that the public improvements meet the design and construction standards required by the Subdivision Regulations and recommends approval.

Financial Consideration:

Upon acceptance, the City will assume ownership and responsibility for the operation and maintenance of the public improvements. Ongoing maintenance costs will be funded through a combination of General Fund and applicable utility revenues.

Attachments:

1. Resolution No. 26-02-02R
2. Petition for Dedications submitted by Developers



RESOLUTION NO. 26-02-02R

RESOLUTION ACCEPTING DEDICATION OF CERTAIN PUBLIC IMPROVEMENTS IN THE DAKOTA ESTATES THIRD SUBDIVISION

WHEREAS, PURPLE COW PROPERTIES, LLC, a South Dakota limited liability company, of 6245 S. Pinnacle Place - Suite 203, Sioux Falls, South Dakota 57108, **FORTE OF ABERDEEN, LLC**, a South Dakota limited liability company, of 6245 S. Pinnacle Place, Sioux Falls, South Dakota 57108, and **DAKOTA ESTATES III, LLC**, a South Dakota limited liability company, of 6245 S. Pinnacle Place, Sioux Falls, South Dakota 57108, (each a “Developer”, and hereinafter collectively referred to as the “Developers”), were the original owners of all of the subdivided real property originally platted as “Dakota Estates Third Subdivision to the City of Aberdeen” (identified hereafter as the “Subdivision”), which plat maps are attached hereto as **Exhibit A**; and

WHEREAS, all lots within the Subdivision are legally described as follows:

Lots 6A, 7B, 7C and 8A in Block 2 of Dakota Estates Third Subdivision in the Southwest Quarter (SW1/4) of Section 6, Township 123 North, Range 63 West of the 5th P.M., Brown County, South Dakota, plat recorded December 28, 2021 as Plat No. 3783 (Parcel IDs 31283, 31285, 31386, and 31387), and any replat thereof, and all public rights-of-way within said real estate to be dedicated to the City of Aberdeen; and

WHEREAS, Developers by petition dated December 11, 2025, request to dedicate, without compensation, to the City of Aberdeen, a South Dakota municipal corporation, and for the City to accept for public use the following public improvements constructed by Developers in rights-of-way, utility easements, and public grounds located wholly within the Subdivision:

- a. Water system;
- b. Sanitary sewer system;
- c. Storm water system;
- d. All platted streets in the Subdivision including those streets designated as North Harrison Street from 27th Avenue Northeast to 24th Avenue Northeast and the extension of 27th Avenue Northeast to North Harrison Street;
- e. Curb and gutter along all streets; and
- f. Sidewalks; and

WHEREAS, said public improvements are in conformance with the applicable subdivision regulations and meet engineering and construction standards established by the City.

NOW, THEREFORE, BE IT RESOLVED by the City Council that the City of Aberdeen hereby appropriates and accepts the following dedicated public improvements in rights-of-way, utility easements, and public grounds in the Subdivision:

- a. Water system;
- b. Sanitary sewer system;
- c. Storm water system;
- d. All platted streets in the Subdivision, including those streets designated as North Harrison Street from 27th Avenue Northeast to 24th Avenue Northeast and the extension of 27th Avenue Northeast to North Harrison Street;
- e. Curb and gutter along said streets; and
- f. Sidewalks constructed within rights-of-way.

BE IT FURTHER RESOLVED that those dedicated public improvements specified above shall hereafter become the property of the City free from all claims from any person or entity and that this Resolution shall operate as a conveyance of each accepted public improvement and that each accepted public improvement placed within a public or platted right-of-way or dedicated public easement is irrevocably dedicated to the public use without any right of reimbursement or compensation to Developers of any kind; and

BE IT FURTHER RESOLVED that Developers shall have no claim, direct or implied, in the title or ownership of the public improvements dedicated to and accepted by the City and that the City hereby takes full title to the public improvements.

BE IT FURTHER RESOLVED that the City hereafter shall enter upon and assume the use, operation, and maintenance according to law of those public improvements accepted.

BE IT FURTHER RESOLVED that the Mayor or City Manager is hereby authorized to execute, and the Finance Officer is authorized to accept, all deeds and instruments necessary to convey the above-described public improvements to the City.

BE IT FURTHER RESOLVED that the Mayor or City Manager is authorized to execute, and to have recorded with the Brown County Register of Deeds, or such official custodian of deeds and instruments, and against all real property within the Subdivision, an affidavit, or similar instrument, acknowledging the City's acceptance of the above-described public improvements.

The foregoing Resolution was considered at a regular meeting of the City Council on the 23rd day of February, 2026, and upon Roll Call vote the Resolution was adopted.

Number of AYES: _____

Number of NAYS: _____

Members abstaining: _____

Travis Schaunaman, Mayor

ATTEST:

Jordan McQuillen, Finance Officer

EXHIBIT A to RESOLUTION NO. 26-02-02R

PLAT OF
 DAKOTA ESTATES THIRD SUBDIVISION IN THE SOUTHWEST QUARTER
 OF SECTION 6, TOWNSHIP 123 NORTH, RANGE 63 WEST OF THE 5TH
 P.M., BROWN COUNTY, SOUTH DAKOTA.

NOTE: THIS PLAT IS A RE-PLAT OF AND SHALL VACATE ALL OF LOTS 6 THRU 33 BLOCK 2, ALL OF BLOCK 3, AND A PORTION OF THE PUBLIC ROAD RIGHT OF WAY FOR VILLA DRIVE ALL OF THE PLAT ENTITLED, "DAKOTA ESTATES SECOND SUBDIVISION IN THE SW¹/₄ OF SECTION 6-T123N-R63W OF THE 5TH P.M., BROWN COUNTY, SOUTH DAKOTA." RECORDED IN PLATS ON PAGE 2932.

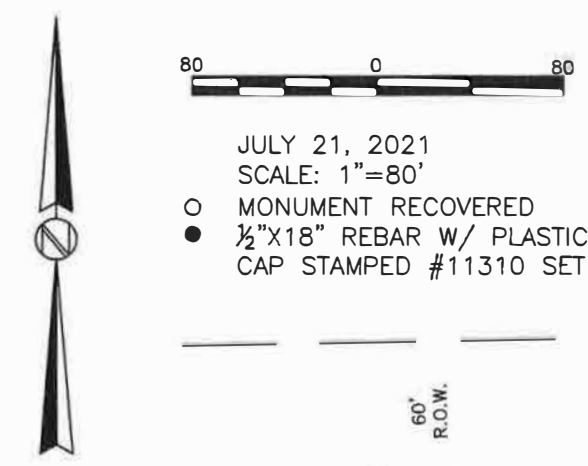

JULY 21, 2021
 SCALE: 1"=80'
 ○ MONUMENT RECOVERED
 ● ½"X18" REBAR W/ PLASTIC CAP STAMPED #11310 SET

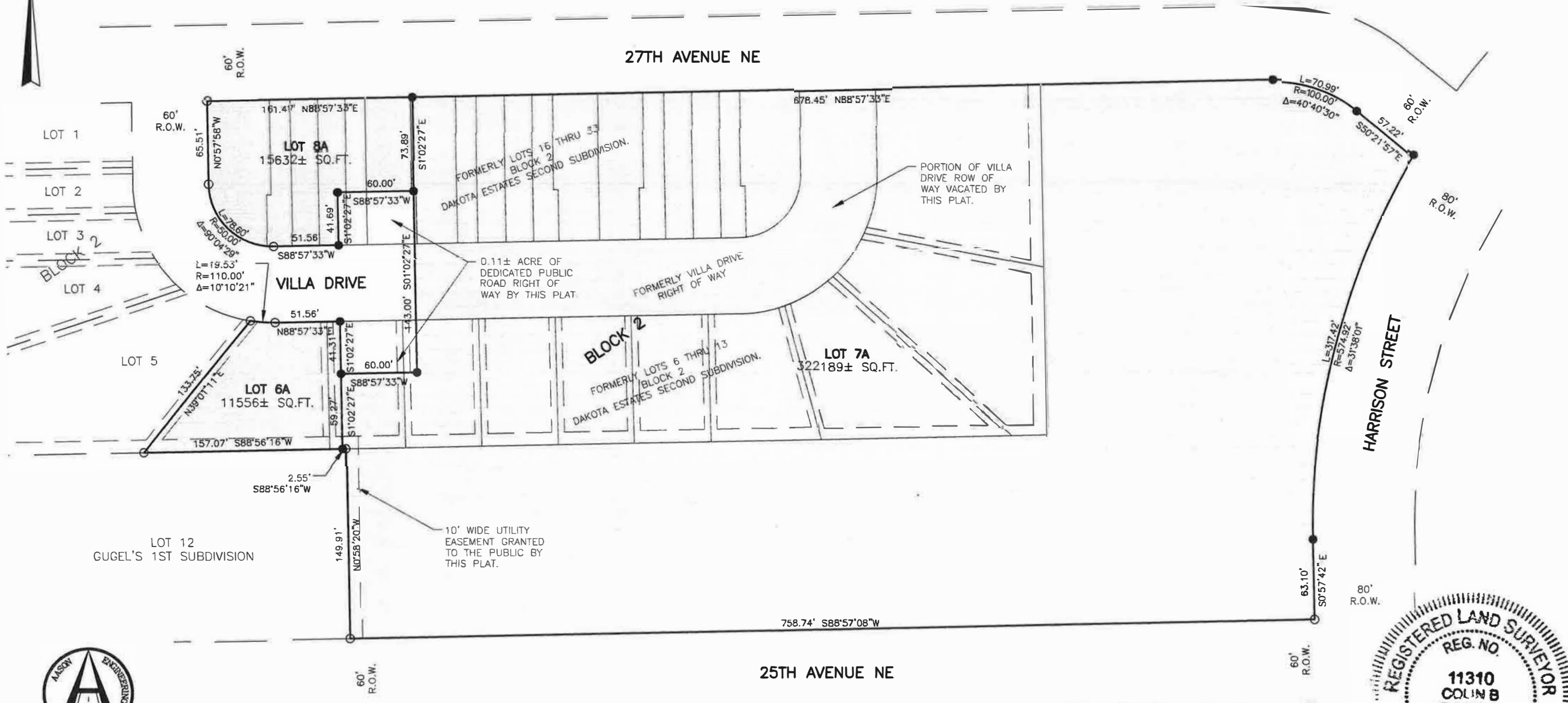

Prepared By
 AASON ENGINEERING COMPANY, INC.

1022 SIXTH STREET S.E.
 WATERTOWN, SD
 Telephone 605-882-2371



Registered Land Surveyor

PLAT OF

LOTS 7B AND 7C BLOCK 2 DAKOTA ESTATES THIRD SUBDIVISION IN THE SOUTHWEST QUARTER OF SECTION 6, TOWNSHIP 123 NORTH, RANGE 63 WEST OF THE 5TH P.M., BROWN COUNTY, SOUTH DAKOTA.

NOTE: THIS PLAT IS A RE-PLAT OF AND SHALL VACATE ALL OF LOT 7A BLOCK 2 OF THE PLAT ENTITLED, "DAKOTA ESTATES THIRD SUBDIVISION IN THE SOUTHWEST QUARTER OF SECTION 6, TOWNSHIP 123 NORTH, RANGE 63 WEST OF THE 5TH P.M., BROWN COUNTY, SOUTH DAKOTA." RECORDED IN PLAT BOOK 2 ON PAGE 3760.



OCTOBER 21, 2021
SCALE: 1"=80'

- MONUMENT RECOVERED
- ½"X18" REBAR W/ PLASTIC CAP STAMPED #11310 SET

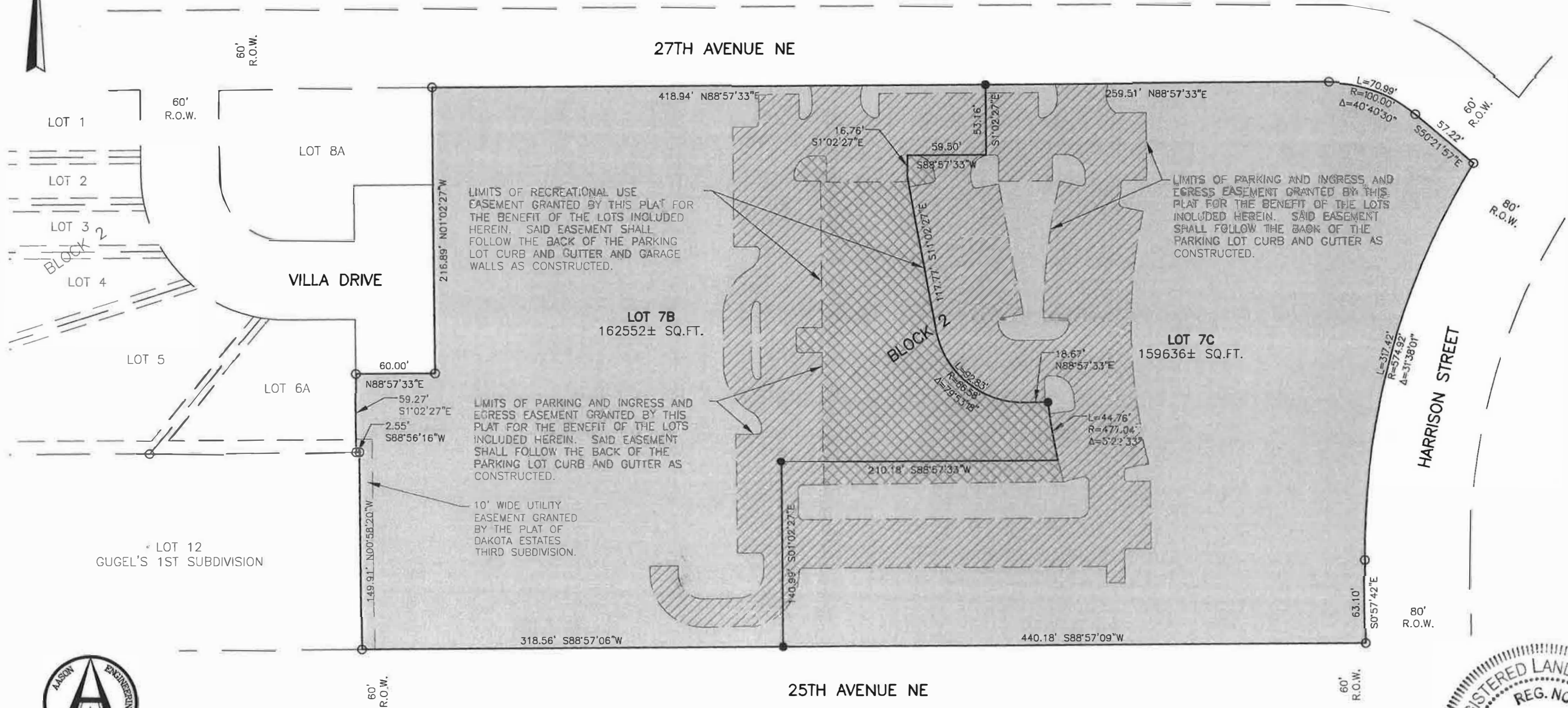

Prepared By
AASON ENGINEERING COMPANY, INC.

1022 SIXTH STREET S.E.
WATERTOWN, SD
Telephone 605-882-2371
City of Aberdeen Council Agenda
February 23, 2026





PETITION FOR DEDICATION OF PUBLIC IMPROVEMENT

Aberdeen City Council
 c/o: City Engineer
 123 South Lincoln Street
 Aberdeen, SD 57401

Date: December 11, 2025

TO THE HONORABLE MAYOR AND CITY COUNCIL:

I/We, the undersigned, as Owner(s) of the subdivision development described below do hereby petition to dedicate the following improvement(s) to the City of Aberdeen, South Dakota, for acceptance as public utilities and to thereafter enter upon and assume the use, operation, and maintenance of the improvement(s).

The undersigned hereby affirm(s) every dedicated improvement has been maintained for one year after completion as verified by the inspection of the Public Works Director/City Engineer.

The undersigned acknowledge(s) that the City of Aberdeen has not appropriated and accepted the improvement(s) in the Development and will not do so until such time as the City Council by resolution determines: (i) the improvement conforms with the applicable subdivision regulations, (ii) meets engineering and construction standards established by ordinance and by the City Engineer, and (iii) is contained wholly within the platted rights-of-way or right has been reserved to the City via perpetual easement to fully access, maintain, modify, upgrade, and/or remove components of the improvement:

1. Name of Development (Subdivision): Dakota Estates Project
2. Legal Description of Parcel/Name of Plat (Attach separate page if necessary): See Exhibit A attached hereto.

3. Improvement for Dedication as Public Improvement:

- Water:** Water system sufficient to meet the projected required capacity demand of the Development, and related appurtenances, per engineered plans and specifications.
- Sanitary Sewer:** Sanitary sewer system sufficient to meet the projected required capacity demand of the Development, and related appurtenances, per engineered plans and specifications.
- Storm Sewer:** Storm water drainage and retention system sufficient to meet the projected required capacity demand of the Development, and related appurtenances, designed and constructed per engineered plans and specifications.
- Streets and Rights-of-Way:** All platted streets in the Development, per engineered plans and specifications.
- Curb and Gutter:** Curb and gutter along all streets, per engineered plans and specifications.
- Other:** Sidewalks.

4. Describe any portion of any Improvement checked above which is NOT located within the Development: None.

IN WITNESS WHEREOF, the undersigned has/have caused this Petition to be approved and executed by person(s) properly authorized so to do on or as of the date(s) ascribed hereto.

Petitioner/Owner Name: Purple Cow Properties, LLC

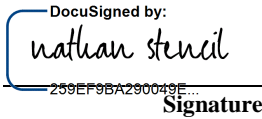
By: Nathan Stencil - 
 Print Name Signature

Title of Authorized Representative: President

Date: 12/11/2025 Email: nstencil@stencil-group.com

Address: 6245 S Pinnacle Place, Suite 203

Sioux Falls SD 57108 Phone: 651-400-7555
City State Zip

Petitioner/Owner Name: Forte of Aberdeen, LLC

(If different than above)

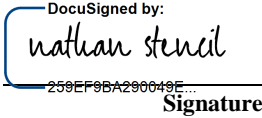
By: Nathan Stencil - 
 Print Name Signature

Title of Authorized Representative: President

Date: 12/11/2025 Email: nstencil@stencil-group.com

Address: 6245 S Pinnacle Place, Suite 203

Sioux Falls SD 57108 Phone: 651-400-7555
City State Zip

Petitioner/Owner Name: Dakota Estates III, LLC

(If different than above)

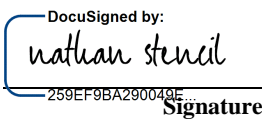
By: Nathan Stencil - 
 Print Name Signature

Title of Authorized Representative: President

Date: 12/11/2025 Email: nstencil@stencil-group.com

Address: 6245 S Pinnacle Place, Suite 203

Sioux Falls SD 57108 Phone: 651-400-7555
City State Zip

(Additional Petitioner signatures may be submitted on separate page)

EXHIBIT A
(Legal Description)

Lots 6A, 7B, 7C and 8A in Block 2 of Dakota Estates Third Subdivision in the Southwest Quarter (SW1/4) of Section 6, Township 123 North, Range 63 West of the 5th P.M., Brown County, South Dakota, plat recorded December 28, 2021 as Plat No. 3783.

Parcel IDs 31283, 31285, 31386, and 31387.



City of Aberdeen

Council Agenda Memo

Agenda Item **7D**

Meeting Date:	2/23/2026	Department:	Community Development
Agenda Section:	New Business	Presented by:	Ken Hubbart Community Development Director
Res./Ord. Number:	26-02-03	Attachments:	4

Agenda Item Title:

Petition to rezone from R-3 to M, Property at 3304 Harrison Street N, legally described as Lot 7, Block 6, HAPI Second North Aberdeen Subdivision to the City of Aberdeen, in the NW¼ of Section 6-Township 123 North-Range 63 West of the 5th P.M., Brown County, South Dakota.

Proposed or Possible Action:

Motion by _____, Second by _____ to approve first reading of proposed Ordinance 26-02-03.

Overview:

The City of Aberdeen is petitioning to rezone this property in order to bring it into a zoning district that is consistent with its municipal use as a city park and existing water retention pond.

Financial Consideration:

N/A

Attachments:

1. Staff Report
2. Petition
3. Overview Map
4. Location Map



Aberdeen City Planning Commission

Staff Report

Rezone R-3 to M

Meeting Date: February 17, 2025

GENERAL INFORMATION

PETITIONER	City of Aberdeen
REQUEST	Rezone from (R-3) High Density Residential District to (M) Municipal, State, and County Use District
LEGAL DESCRIPTION	Lot 7, Block 6, HAPI 2 nd North Aberdeen Subdivision to the City of Aberdeen, in the NW ¹ / ₄ of Section 6, Township 123 North, Range 63 West of the 5th P.M., Brown County, South Dakota
LOCATION	3304 Harrison Street North – city park and holding pond in the NE corner of the HAPI North Subdivisions
EXISTING ZONING	High Density Residential District
PROPOSED ZONING	Municipal, State, and County Use District
SURROUNDING ZONING	
North:	High Density Residential District
South:	High Density Residential District & Municipal, State, and County Use District
East:	High Density Residential District & Agricultural District
West:	High Density Residential District
PUBLIC UTILITIES	City Water and Sewer
REPORTED BY	Eric Miller

RECOMMENDATION: Staff recommends approval of this petition to rezone.

GENERAL COMMENTS: The petitioner is requesting this petition to rezone in order to bring the property into a district that is consistent with its municipal use as the future site of a city park and an existing water retention pond.

REVIEW: Staff have reviewed this petition to rezone and concur with its approval.



Petition to Rezone Planning Commission

123 South Lincoln Street
Aberdeen, SD 57401
605-626-7017

The Planning Commission Board meets the 3rd Tuesday of each month at 6:00 P.M. or 7:00 P.M. in the Council Chambers on the first floor of City Hall. Fees: \$210.00

Mayor and City Council:

I/We, the undersigned, do hereby petition the City Council of Aberdeen, South Dakota, to rezone property as follows:

Petitioner Information					
Petitioner/Title/(s):	City of Aberdeen				
[REDACTED]					
Phone:	605 - 626 - 7017				
Mailing Address:	123 Lincoln St. S.				
City:	Aberdeen	State:	SD	Zip:	57401

Property Information			
Address/Location:	3304 Harrison St. N. / Parkland in the NE corner of HAPI		
Legal Description:	Lot 7, Block 6, HAPI 2 nd North Subdivision to the ^{North} Sub. City of Aberdeen, in the NW 1/4 of Sec. 6-T123N-R63W of the 5 th P.M., Brown County, South Dakota		
Current Zoning:	R-3	Proposed Zoning:	M
Size of Parcel:	6.99 ac.		
Existing Land Use:	City Park		

Purpose of Petition	
To bring the property into a district consistent with its municipal use.	
	01/29/26
Signature	Date

Office Use Only					
Ordinance No:	26-02-03				
Date:	1/29/26	Receipt #	N/A	Fee:	N/A
Sign Issued <input checked="" type="checkbox"/> EM	Site Plan <input type="checkbox"/>				
PC Meeting:	2/17/26	1 st Reading:	2/23/26	2 nd Reading/Final Adoption:	3/2/26
Received By:	EM				

Rezone Overview

Address: 3304 Harrison St. N

Legal Description: Lot 7, Block 6 HAPI North Subdivision.

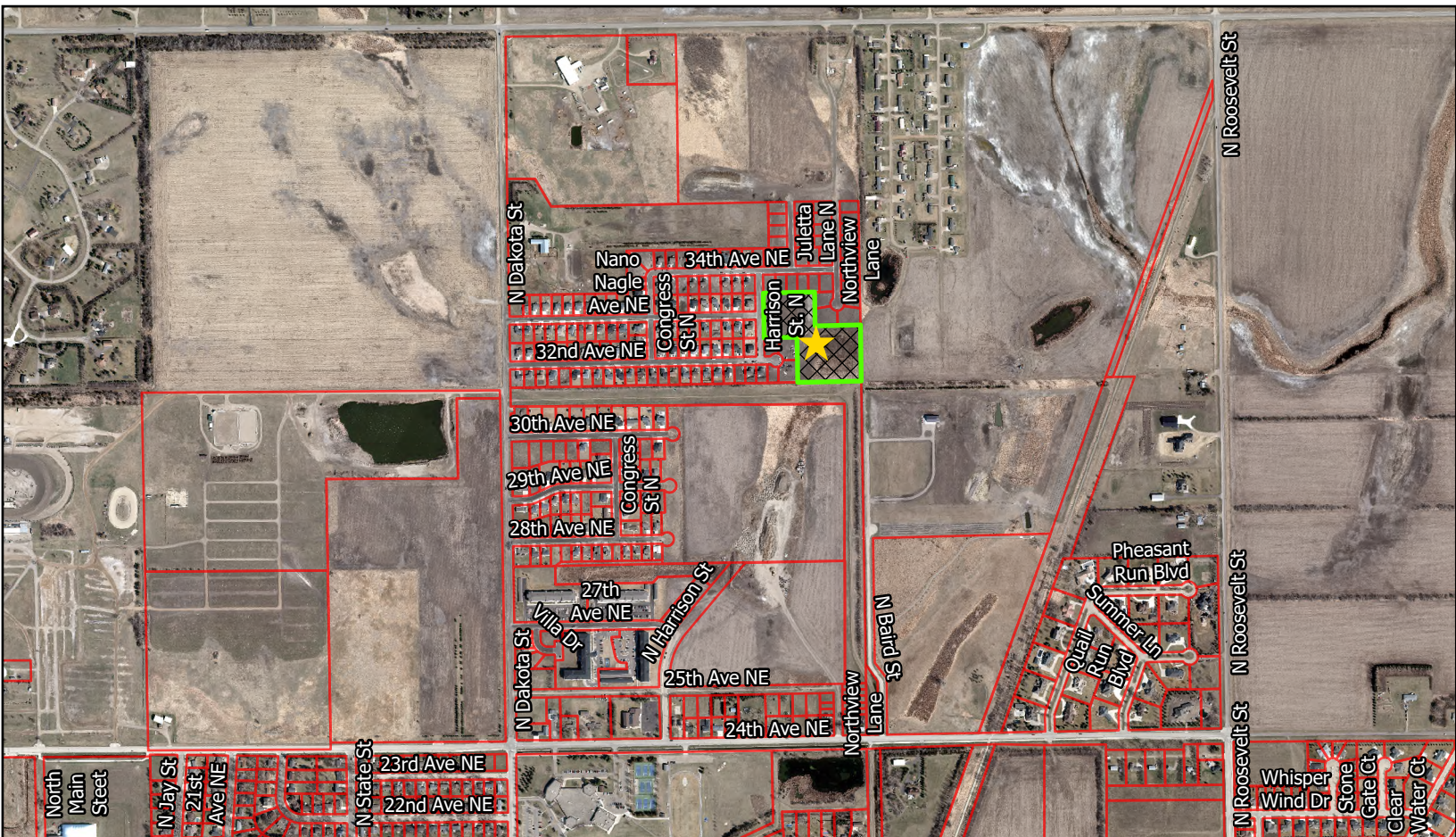

For Advisory purposes only; not a legal document.



Rezone Proposal

Address: 3304 Harrison St. N

Legal Description: Lot 7, Block 6 HAPI North Subdivision.

Current Zoning: R-3 (High Density Residential)

Proposed Zoning: M (Municipal, State, and County Use District)

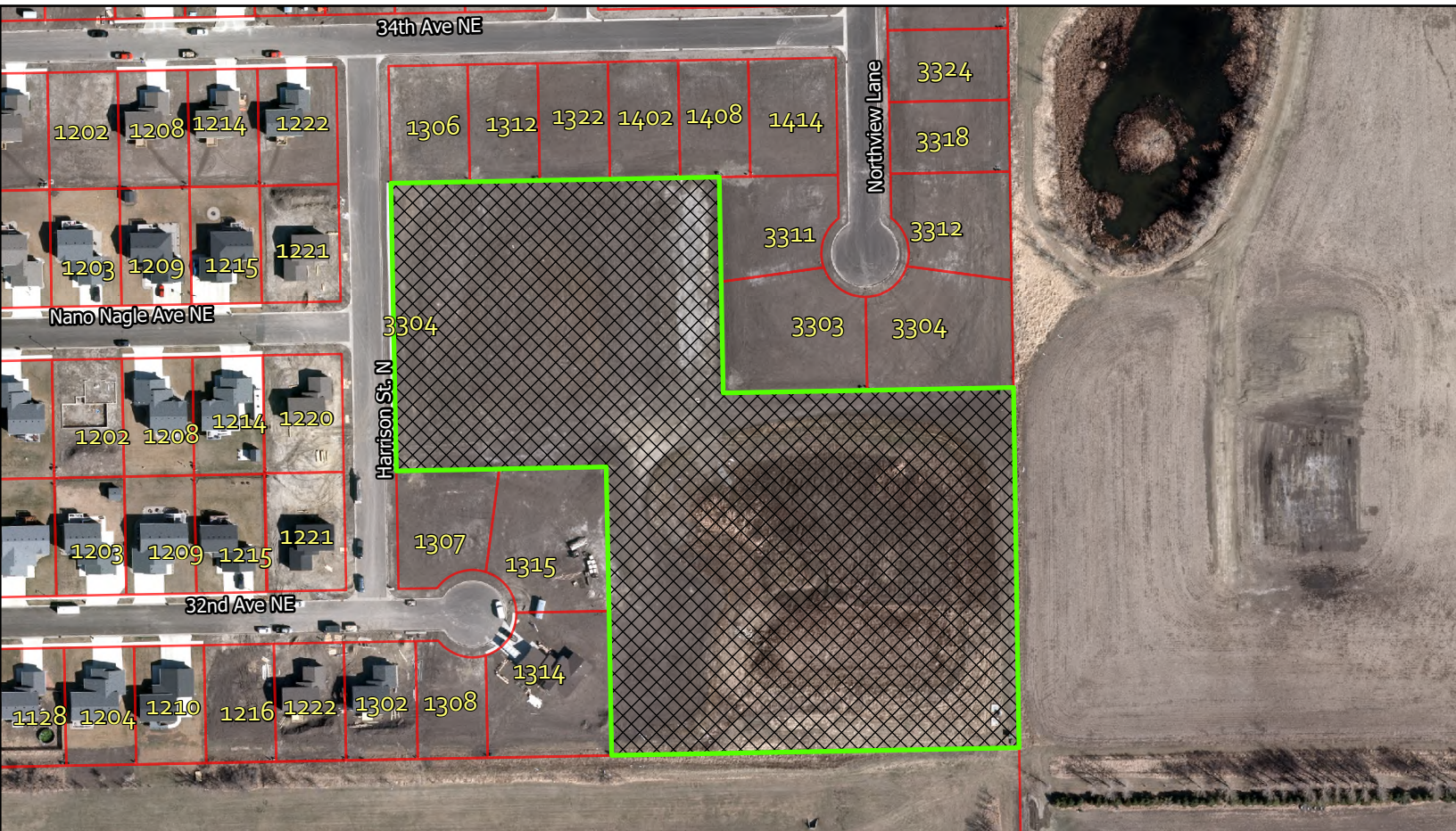

Ordinance No: 26-02-03

Date: 1/29/2026



City of Aberdeen

Council Agenda Memo

Agenda Item 7E

Meeting Date:	2/23/2026	Department:	Community Development
Agenda Section:	New Business	Presented by:	Ken Hubbart Community Development Director
Res./Ord. Number:	26-02-04	Attachments:	4

Agenda Item Title:

Petition to rezone from R-2 to M, Property at 2006 Lawson Street S, legally described as Lot 2, Second Replat of Southaven First Addition to the City of Aberdeen, in the NW¼ of Section 30-Township 123 North-Range 63 West of the 5th P.M., Brown County, South Dakota.

Proposed or Possible Action:

Motion by _____, Second by _____ to approve first reading of proposed Ordinance 26-02-04.

Overview:

The City of Aberdeen is petitioning to rezone this property in order to bring it into a zoning district that is consistent with its municipal use as a city park.

Financial Consideration:

N/A

Attachments:

1. Staff Report
2. Petition
3. Overview Map
4. Location Map



Aberdeen City Planning Commission

Staff Report

Rezone R-2 to M

Meeting Date: February 17, 2025

GENERAL INFORMATION

PETITIONER	City of Aberdeen
REQUEST	Rezone from (R-2) Medium Density Residential District to (M) Municipal, State, and County Use District
LEGAL DESCRIPTION	Lot 2, 2 nd Replat of Southaven First Addition to the City of Aberdeen, in the NW¼ of Section 30, Township 123 North, Range 63 West of the 5th P.M., Brown County, South Dakota
LOCATION	2006 Lawson Street South – future city park, south of First Baptist Church
EXISTING ZONING	Medium Density Residential District
PROPOSED ZONING	Municipal, State, and County Use District
SURROUNDING ZONING	
North:	Medium Density Residential District
South:	Agricultural District
East:	High Density Residential District
West:	Medium Density Residential District
PUBLIC UTILITIES	City Water and Sewer
REPORTED BY	Eric Miller

RECOMMENDATION: Staff recommends approval of this petition to rezone.

GENERAL COMMENTS: The petitioner is requesting this petition to rezone in order to bring the property into a district that is consistent with its municipal use as the future site of a city park.

REVIEW: Staff have reviewed this petition to rezone and concur with its approval.



Petition to Rezone Planning Commission

123 South Lincoln Street
Aberdeen, SD 57401
605-626-7017

The Planning Commission Board meets the 3rd Tuesday of each month at 6:00 P.M. or 7:00 P.M. in the Council Chambers on the first floor of City Hall. Fees: \$250.00

Mayor and City Council:

I/We, the undersigned, do hereby petition the City Council of Aberdeen, South Dakota, to rezone property as follows:

Petitioner Information					
Petitioner/Title/(s):	City of Aberdeen				
Phone:	605-626-7017				
Mailing Address:	123 Lincoln St. S.				
City:	Aberdeen	State:	SD	Zip:	57401

Property Information			
Address/Location:	2006 Lawson St. South/SE corner of First Baptist Church lot		
Legal Description:	Lot 2, 2 nd Replat of Southaven First Addition to the City of Aberdeen in the NW 1/4 of Sec 30 - T 123N - R 63W of the 5 th PM., Brown County, South Dakota		
Current Zoning:	R-2	Proposed Zoning:	M
Size of Parcel:	.49 ac.		
Existing Land Use:	City Park		

Purpose of Petition	
To bring the property into a district consistent with its municipal use	
Signature	01/29/26 Date

Office Use Only					
Ordinance No:	26-02-04				
Date:	1/29/26	Receipt #	N/A	Fee:	N/A
Sign Issued <input checked="" type="checkbox"/> EM	Site Plan <input type="checkbox"/>				
PC Meeting:	2/17/26	1 st Reading:	2/23/26	2 nd Reading/Final Adoption:	
Received By:	EM				

Rezone Overview

Address: 2006 Lawson St. South

Legal Description: Lot 2, 2nd Replat of Southaven 1st Addition.

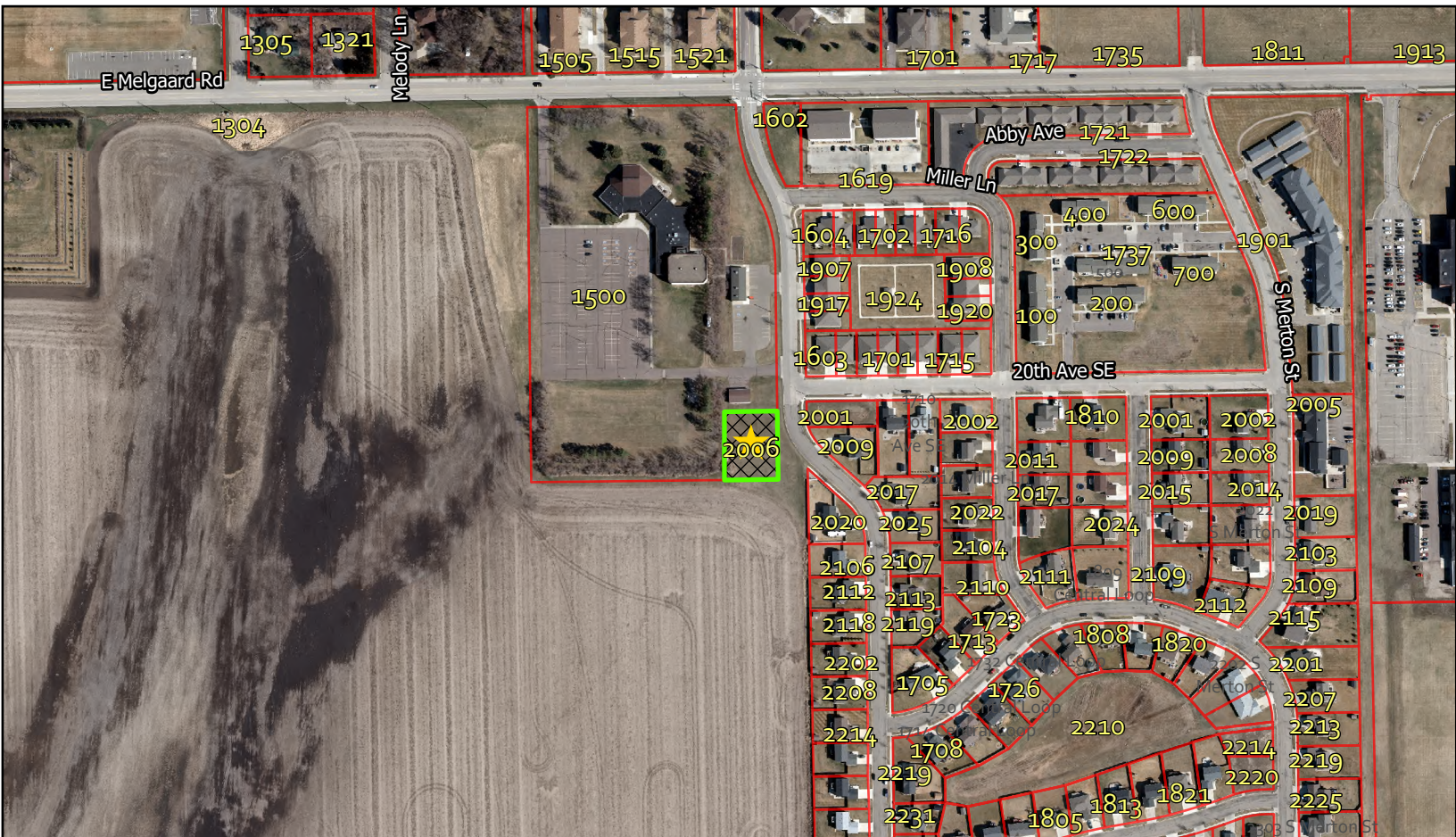

For Advisory purposes only; not a legal document.



Rezone Proposal

Address: 2006 Lawson ST. S

Legal Description: Lot 2, 2nd Replat of Southaven 1st Addition.

Current Zoning: R-2 (Medium Density Residential)

Proposed Zoning: M (Municipal, State, and County Use District)

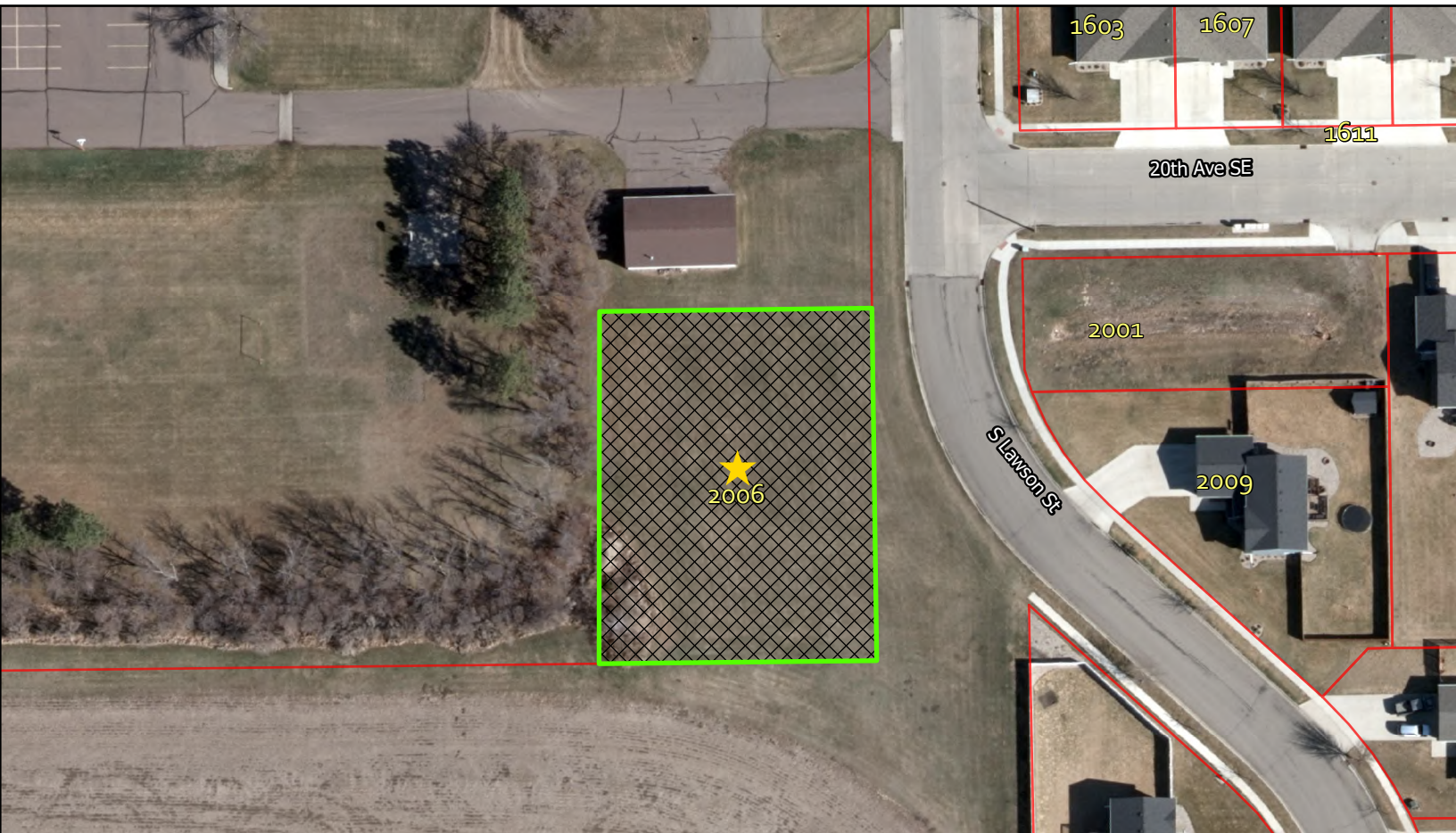

Ordinance No: 26-02-04

Date: 1/29/2026



City of Aberdeen

Council Agenda Memo

Agenda Item 7F

Meeting Date:	2/23/2026	Department:	Community Development
Agenda Section:	New Business	Presented by:	Ken Hubbart Community Development Director
Res./Ord. Number:	26-02-05	Attachments:	4

Agenda Item Title:

Petition to rezone from I-1 to M, Property at 4406 Eighth Avenue NE, legally described as Lot 1, NE Water Tower Addition to the City of Aberdeen, in the NE¼ of the NW¼ of Section 16-Township 123 North-Range 63 West of the 5th P.M., Brown County, South Dakota.

Proposed or Possible Action:

Motion by _____, Second by _____ to approve first reading of proposed Ordinance 26-02-05.

Overview:

The City of Aberdeen is petitioning to rezone this property in order to bring it into a zoning district that is consistent with its municipal use as a city water tower.

Financial Consideration:

N/A

Attachments:

1. Staff Report
2. Petition
3. Overview Map
4. Location Map



Aberdeen City Planning Commission

Staff Report

Rezone I-1 to M

Meeting Date: February 17, 2025

GENERAL INFORMATION

PETITIONER	City of Aberdeen
REQUEST	Rezone from (I-1) Industrial Park District to (M) Municipal, State, and County Use District
LEGAL DESCRIPTION	Lot 1, NE Water Tower Addition to the City of Aberdeen, in the NE ¹ / ₄ of the NW ¹ / ₄ of Section 16, Township 123 North, Range 63 West of the 5th P.M., Brown County, South Dakota
LOCATION	4406 Eighth Avenue NE – new water tower east of 3-M
EXISTING ZONING	Industrial Park District
PROPOSED ZONING	Municipal, State, and County Use District
SURROUNDING ZONING	
North:	Unrestricted Industrial District
South:	Industrial Park District
East:	Unrestricted Industrial District
West:	Industrial Park District
PUBLIC UTILITIES	City Water and Sewer
REPORTED BY	Eric Miller

RECOMMENDATION: Staff recommends approval of this petition to rezone.

GENERAL COMMENTS: The petitioner is requesting this petition to rezone in order to bring the property into a district that is consistent with its municipal use as the future site of a city water tower.

REVIEW: Staff have reviewed this petition to rezone and concur with its approval.



Petition to Rezone Planning Commission

123 South Lincoln Street
Aberdeen, SD 57401
605-626-7017

The Planning Commission Board meets the 3rd Tuesday of each month at 6:00 P.M. or 7:00 P.M. in the Council Chambers on the first floor of City Hall. Fees: \$210.00

Mayor and City Council:

I/We, the undersigned, do hereby petition the City Council of Aberdeen, South Dakota, to rezone property as follows:

Petitioner Information					
Petitioner/Title/(s):	City of Aberdeen				
Phone:	605-626-7017				
Mailing Address:	123 Lincoln St S.				
City:	Aberdeen	State:	SD	Zip:	57401

Property Information			
Address/Location:	4406 8 th Ave NE / New water tower lot east of 3-M		
Legal Description:	Lot 1, NE Water Tower Addition to the City of Aberdeen, in the NE 1/4 of the NW 1/4 of Sec. 16 - T 123N - R 63W of the 5 th P.M., Brown County, South Dakota		
Current Zoning:	I-1	Proposed Zoning:	M
Size of Parcel:	2.066 ac		
Existing Land Use:	City Water Tower		

Purpose of Petition	
To bring the property into a district consistent with its municipal use.	
Signature	Date 2/29/26

Office Use Only					
Ordinance No:	26-02-05				
Date:	1/29/26	Receipt #	N/A	Fee:	N/A
Sign Issued <input checked="" type="checkbox"/> EM	Site Plan <input type="checkbox"/>				
PC Meeting:	2/17/26	1 st Reading:	2/23/26	2 nd Reading/Final Adoption:	3/2/26
Received By:	EM				

Rezone Overview

Address: 4406 8th Ave NE

Legal Description: Lot 1, NE Water Tower Addition.

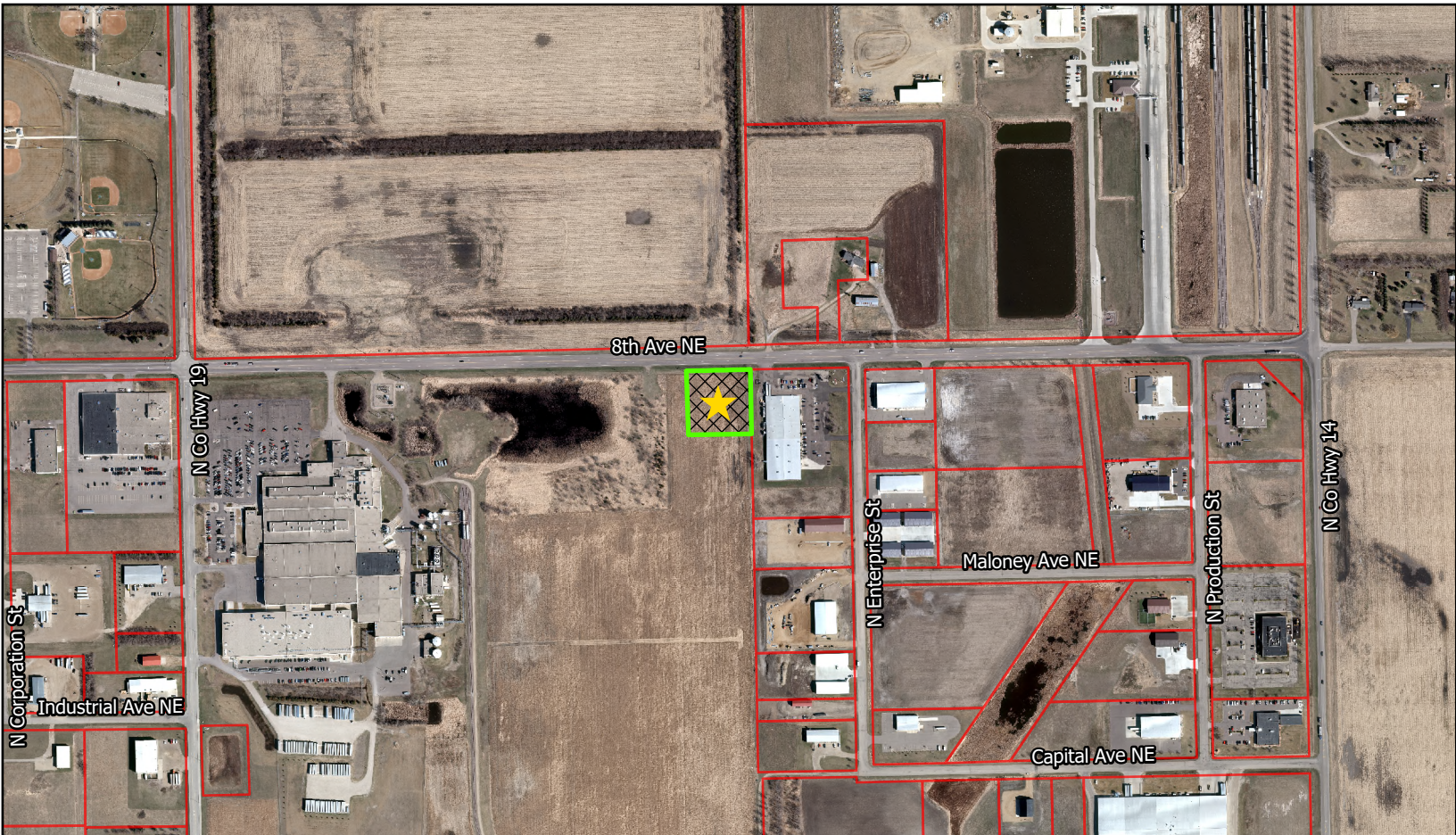

For Advisory purposes only; not a legal document.



Rezone Proposal

Address: 4406 8th Ave NE

Legal Description: Lot 1, NE Water Tower Addition.

Current Zoning: I-1 (Industrial Park District)

Proposed Zoning: M (Municipal, State, and County Use District)

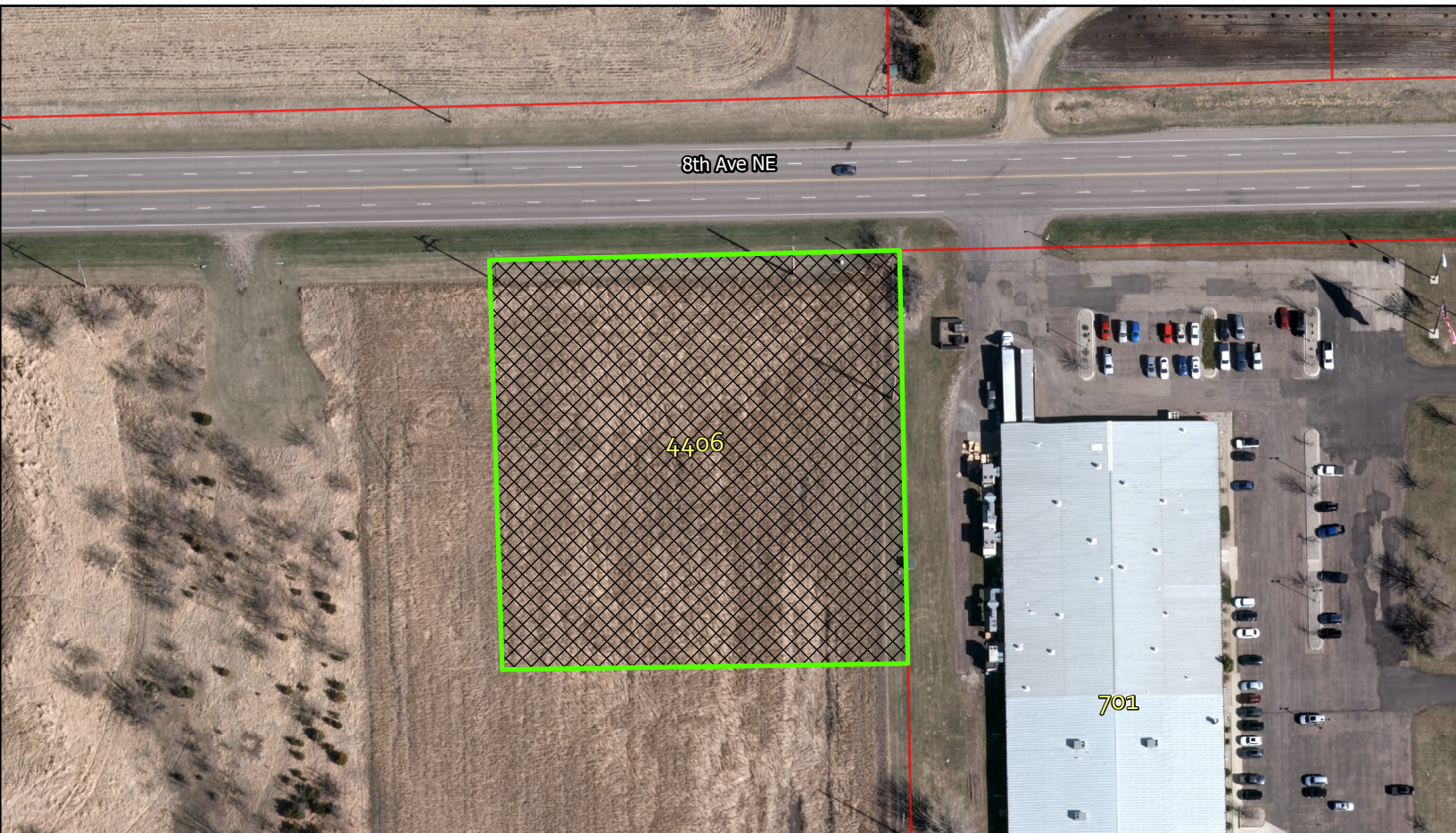

Ordinance No: 26-02-05

Date: 1/29/2026



City of Aberdeen

Council Agenda Memo

Agenda Item 7G

Meeting Date:	2/23/2026	Department:	Community Development
Agenda Section:	New Business	Presented by:	Ken Hubbart Community Development Director
Res./Ord. Number:	N/A	Attachments:	2

Agenda Item Title:

Permission to install supergraphic signs in a (C-3) Central Business Zoning District.

Proposed or Possible Action:

Motion by _____, Second by _____ to approve the installation of two previously painted supergraphic signs to remain on the west side of building located at 1122 Main Street S (Lords & Ladies Beauty Salon).

Overview:

Two murals were previously applied to the building without prior consent of the City Council. The murals are purely artistic in nature and do not directly advertise any commercial use, therefore staff recommends approval of this request with the condition that the two super graphic signs are maintained in accordance with Section 60-341(g) of Aberdeen City Code.

Financial Consideration:

N/A

Attachments:

1. Staff Report
2. Photos of two Super Graphic Signs



Aberdeen City Planning Commission

Staff Report

Super Graphics in C-3 District

Meeting Date: February 17, 2025

GENERAL INFORMATION

PETITIONER	Sarah Jones
REQUEST	Permission to install new super graphic signs in a (C-3) Central Business District
LEGAL DESCRIPTION	Lot 1, T. and S. Jones Consolidation Subdivision in Aberdeen, in the NW¼ of Section 24, Township 123 North, Range 64 West of the 5th P.M., Brown County, South Dakota
LOCATION	1122 Main Street South – Lords & Ladies Beauty Salon
EXISTING ZONING	Central Business District
SURROUNDING ZONING	
North:	High Density Residential District
South:	Neighborhood Commercial District
East:	Central Business District
West:	Unrestricted Industrial District
PUBLIC UTILITIES	City Water and Sewer
REPORTED BY	Eric Miller

RECOMMENDATION: Staff recommends approval of this request.

GENERAL COMMENTS: The petitioner is requesting to allow two previously painted super graphic signs/murals to remain on the west side of the building. These murals were painted several years ago and went unnoticed until recently. Super graphic signs or murals are allowed provided they do not directly advertise the business where they are located and their value is purely artistic and require permission from the City Planning Commission and City Council. As these were previously painted, this request is to bring their existence into compliance with City Zoning Code.

REVIEW: Staff have reviewed this request and concur with its approval with the stipulation that the super graphics are maintained in accordance with Sec. 60-341(g) of the Aberdeen City Code.

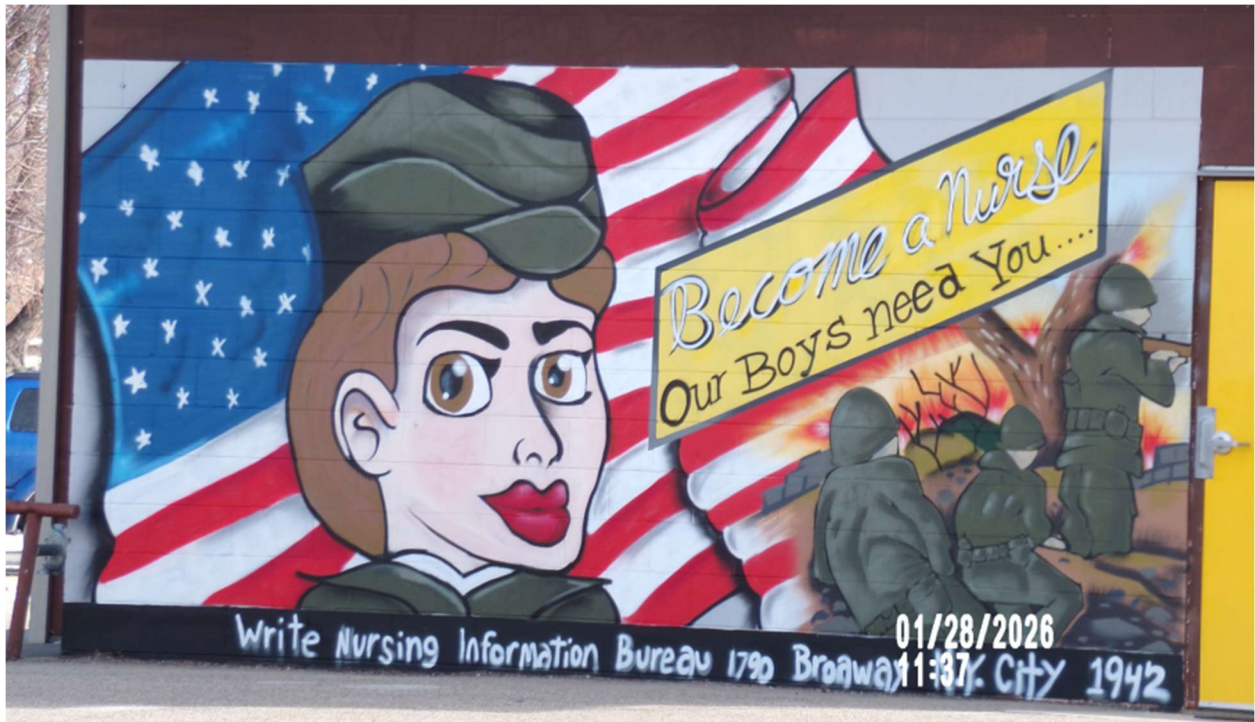



City of Aberdeen

Council Agenda Memo

Agenda Item **7H**

Meeting Date:	2/23/2026	Department:	Economic Development
Agenda Section:	New Business	Presented by:	Amber Schwab, Ken Hubbard, Dave McNeil
Res./Ord. Number:	NA	Attachments:	3

Agenda Item Title:

Possible authorization for City Manager to sign consent form for South Dakota Department of Agriculture and Natural Resources (DANR) Brownfields Grant assessment of certain city-owned facilities.

Proposed or Possible Action:

Motion and second to authorize the City Manager to sign the consent form needed to proceed with the assessment with our DANR representative.

Overview:

City staff have identified the need to conduct a comprehensive assessment of Civic Arena, Washinton Building, and Civic Theater properties currently owned by the City. The purpose of this evaluation is to identify potential liabilities and determine whether any environmental or structural abatement costs may qualify for full or partial funding through South Dakota DANR programs.

The DANR Brownfields program currently has assessment funds available.

Assessment includes:

- Phase I – gathering background information for potential recognized environmental concerns
- Phase II – quantifying the environmental concerns with samples
- Clean Up Planning – proposal written up by an environmental contractor for cost and recommendation for removal of ecological concerns.
- Structural Assessment – identify structural concerns and give recommendations

Through this effort, this information will assist the City to establish a strategic framework for prioritizing maintenance, planning for capital improvements, and aligning facility usage with long-term community goals. This proactive approach will promote responsible stewardship of public assets while positioning the City to leverage available funding opportunities and support future development initiatives.

Financial Consideration:

None, fully funded by DANR through the Brownfeilds Program when awarded.

Attachments:

1. CWAG Consent for access and waiver of liability form
2. CWAG information sheet
3. TAB info Sheet



Consent For Access To Property and Waiver of Liability

Owner Name:	
Owner Address:	
Owner City:	
Property Address:	
Property City:	
Approximate Property size	

I, the owner of the property described above or his authorized representative, consent to officers, employees, and authorized representatives of the South Dakota Department of Agriculture and Natural Resources (DANR) entering and having access to the property described above for the following purposes:

- Obtaining information necessary to prepare a ASTM Phase I and Phase II Assessment of the buildings and property.
- Obtaining information necessary to do asbestos/lead inspections of the building(s);
- the taking of such soil, water, air, and interior substance samples as may be determined to be necessary;
- the sampling of any solids or liquids stored or disposed of on site;
- the drilling of holes and installation of monitoring wells for subsurface investigation;
- other actions related to the investigation of surface or subsurface contamination;
- performing assessment actions including abandoned tank system removal and site stabilization, and other actions deemed necessary to protect human health and the environment.

The DANR and their contractors agree to properly abandon the boring holes and ground water monitoring wells in accordance with state law at no cost to the property owner. I acknowledge that these actions by DANR and their contractors are undertaken pursuant to a request for state assistance under the South Dakota Brownfields Revitalization and Economic Development Program outlined in South Dakota Codified Law 46A-1-100 through 46A-1-106.

RELEASE AND WAIVER OF LIABILITY, ASSUMPTION OF THE RISK AND INDEMNITY AGREEMENT

By my signature below, I acknowledge that I am aware of, appreciate the character of, and voluntarily assume the risks involved in participating in the South Dakota Brownfields Revitalization and Economic Development Program.

By my signature below, on behalf of myself, my heirs, next of kin, successors in interest, assigns, personal representatives, and agents, I hereby:

1. Waive any claim or cause of action against and release from liability the State of South Dakota, its officers, employees, and agents for any liability for injuries to my person or property resulting from my participation in the activity listed above;
2. Agree to indemnify and hold harmless the State of South Dakota, its officers, employees, and agents for any claims, causes of action, or liability to any other person arising from my participation in the activity listed above; and

I HAVE READ THIS RELEASE AND WAIVER OF LIABILITY, ASSUMPTION OF THE RISK AND INDEMNITY AGREEMENT, FULLY UNDERSTAND ITS TERMS, UNDERSTAND THAT I HAVE GIVEN UP SUBSTANTIAL RIGHTS BY SIGNING IT, AND HAVE SIGNED IT FREELY AND VOLUNTARILY WITHOUT ANY INDUCEMENT, ASSURANCE, OR GUARANTEE BEING MADE TO ME AND INTEND MY SIGNATURE TO BE A COMPLETE AND UNCONDITIONAL RELEASE OF ALL LIABILITY TO THE GREATEST EXTENT ALLOWED BY LAW.

Name:			
Address:			
Phone #:		Date:	
Signature:			

COMMUNITY WIDE ASSESSMENT GRANT

BROWNFIELDS
PROGRAM

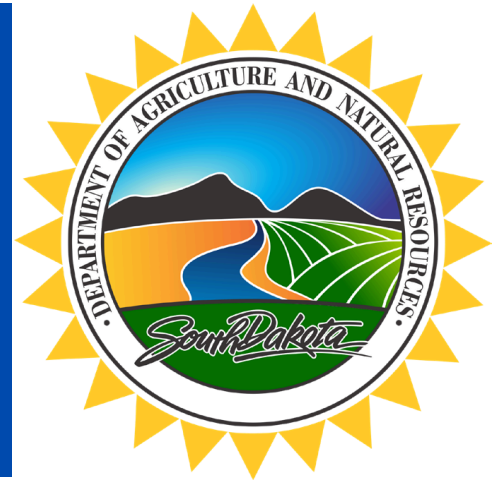

South Dakota Department of Agriculture & Natural Resources

What is a Brownfield?

A brownfield is a property where expansion, redevelopment, or reuse may be complicated by the presence or potential presence of a hazardous substance, pollutant, or contaminant. Petroleum, asbestos, and lead-based paint are commonly found when investigating older properties.

Brownfields are present in nearly every community, from former dry cleaners and gas stations to vacant retail properties and former industrial sites. Redevelopment of these properties may be stalled due to concerns associated with the costs of assessment.



Assessment Assistance

DANR provides free assessment services for qualified properties. These funds are available to private and public entities. Services include site assessment, characterization, response, and cleanup planning. Brownfield assessment funds may only be used at sites where there is a release or substantial threat of release of a hazardous substance, pollutant, or contaminant. There is no limit on the number of sites an applicant can request assistance for; however, program funds are limited, and requests may be prioritized based on the level of contamination or the community's commitment to cleanup and redevelopment.

Asbestos

Hazardous
Substances

Phase I & II

Clean Up
Planning

Economic Benefits

No financial match is required. For properties that meet eligibility requirements, DANR may be able to cover all costs associated with property assessment work. Brownfields funding can play a crucial role in helping local communities with efforts to revitalize blighted properties. This opportunity can generate jobs, expand the tax base, and provide other benefits, such as creating a park or residential area.



Program Contact:

Macy Jo Peterson

MacyJo.Peterson@State.sd.us

605-773-3296

SOUTH DAKOTA BROWNFIELDS RESOURCES

WHAT IS A BROWNFIELD?

A brownfield is a property where expansion, redevelopment or reuse may be complicated by the presence or potential presence of a hazardous substance, pollutant or contaminant.

Brownfields are present in nearly every community, from dry cleaners and gas stations to vacant retail properties and former industrial sites. Nationally, the [Comprehensive Environmental Response, Compensation and Liability Act of 1980](#) (CERCLA, also known as Superfund) and the [Resource Conservation and Recovery Act](#) (RCRA) were established to address the threat of hazardous wastes sites and to prevent future contamination from occurring. Although some brownfield sites are governed by CERCLA or RCRA, most are regulated on a state level. In South Dakota, these sites are regulated by the Department of Agriculture and Natural Resources (DANR).



SOUTH DAKOTA DEPARTMENT OF AGRICULTURE AND NATURAL RESOURCES (DANR)

BROWNFIELDS PROGRAM OVERVIEW

The South Dakota Department of Agriculture and Natural Resources (DANR) Brownfields Program monitors and manages the remediation of spills, releases, and contaminated sites. DANR Brownfields staff are responsible for ensuring brownfields cleanup work meets applicable state and federal criteria, in addition to managing several programs to help communities assess, clean up, and redevelop their brownfield sites.

SPILL REPORTING

If gasoline, pesticides, solvents, or other substances are spilled or released, they may harm soil, air, surface and groundwater, wildlife, fish, or humans. If a spill or release occurs, it should be reported to the DANR Inspection, Compliance, and Remediation Program (ICR), which was established to identify the type and quantity of released substances, complete required reporting, and ensure that the spill or release is appropriately treated as quickly as possible.

BROWNFIELDS ASSESSMENT ASSISTANCE

DANR provides free assessment services to qualified cities, counties, and local development groups. Services include site assessment, characterization, response, or cleanup planning and design. Brownfield assessment funds may only be used at sites where there is a release or substantial threat of release of a hazardous substance, pollutant, or contaminant. There is no limit on the number of sites an applicant can request assistance for, although program funds are limited and requests may be prioritized based on level of contamination or community commitment toward cleanup and redevelopment. Private property owners are not eligible for assessment assistance, although an eligible entity may request assistance on their behalf.

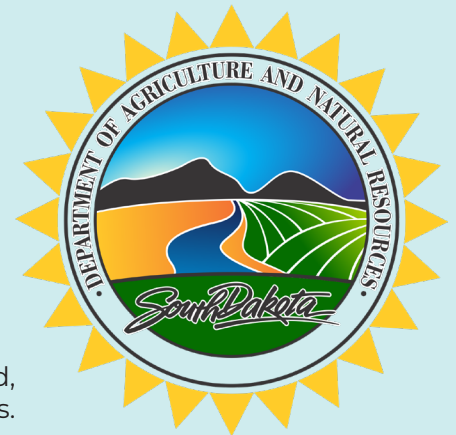

DANR PETROLEUM TANK REMOVAL PROGRAM

ABANDONED TANK REMOVAL PROGRAM

The Abandoned Tank Removal Program was established in 2000 to authorize DANR to remove underground storage tanks, including abandoned petroleum and waste oil tanks at gas stations and commercial fuel vendors that were closed before April 1, 1988, as well as abandoned petroleum tanks located at noncommercial operations. Interested parties should complete the [Tank Removal Form](#) and submit it to the state. If the site is eligible, DANR will remove the tank(s) and complete the necessary cleanup at no cost to the owner.

TECHNICAL ASSISTANCE PROGRAMS

EPA TECHNICAL ASSISTANCE TO BROWNFIELDS (TAB)

The EPA TAB program provides free technical assistance to communities on brownfields issues, with the goal of increasing the community's understanding and involvement in brownfield cleanup and revitalization, and helping put brownfield properties back to productive use. Kansas State University (KSU) is the TAB provider to South Dakota, as well as all of EPA Regions 5, 6, 7, and 8. KSU provides planning and redevelopment assistance, financial analysis, technical document review, community outreach assistance, online tools, and more.

KANSAS STATE
UNIVERSITY



TAB
Technical Assistance
to Brownfields

CONTACTS

KSU TAB

Maggie Belanger
Region 8 Director
785-230-6825
maggiejessie@ksu.edu

KSU TAB

Kate Lucas, AICP
Region 8 Assistant Director
817-565-2885
katelucas@ksu.edu

OTHER PROGRAMS AND RESOURCES

TOOLBOX FOR COMMUNITY REDEVELOPMENT

HANDBOOK FOR PETROLEUM ASSESSMENT AND CORRECTIVE ACTION

CONTACT INFORMATION

Brownfields Program

Macy Jo Peterson
605-773-3296
MacyJo.Peterson@state.sd.us

Brownfields Program

Nayyer Syed
605-773-3296
nayyer.syed@state.sd.us

Tank Program Manager

Kayla Fawcett
605-773-3296
Kayla.Fawcett@state.sd.us

Spill Program Manager

Trish Kindt
605-773-3296
trish.kindt@state.sd.us



City of Aberdeen

Council Agenda Memo

Agenda Item **7I**

Meeting Date:	2/23/2026	Department:	Public Works
Agenda Section:	New Business	Presented by:	Stu Nelson
Res./Ord. Number:	NA	Attachments:	2

Agenda Item Title:

Possible approval of 2026 Seal Coat Aggregates

Proposed or Possible Action:

Motion and second to award Bid Option A in the amount of \$118,800.00 (\$29.70/ton Pea Rock) to L.G. Everist, Inc. of Sioux Falls, SD; Bid Option C in the amount of \$96,000.00 (\$48.00/ton of Crushed Granite) to HF Jacobs & Son Construction, Inc. of Aberdeen, SD; and Bid Option D in the amount of \$45,000.00 (\$18.00/ton of Crushed Aggregate Basecourse) to HF Jacobs & Son Construction, Inc. of Aberdeen, SD for a total bid amount of \$259,800.00.

Overview:

NA

Financial Consideration:

2026 Special Sales Tax budget in the amount of \$259,800.00.

Attachments:

- 2

BIDS RECIEVED FEBRUARY 17, 2026 - 2 PM AT ABERDEEN SOUTH DAKOTA

FOR AGGREGATES

NAME OF BIDDER -		ADDRESS OF BIDDER-		L.G. EVERIST, INC. 350 S MAIN AVE STE 400 SIOUX FALLS, SD 57104		LIEN TRANSPORTATION CO PO BOX 40 ABERDEEN, SD 57402-0040		JENSEN ROCK & SAND, INC. PO BOX 609 MOBRIDGE, SD 57601		KEVIN BOURDON 2118 S LAWSON ST ABERDEEN, SD 57401		2025 BID PRICE
ITEM	DESCRIPTION	UNIT	UNIT PRICE	TOTAL \$	UNIT PRICE	TOTAL \$	UNIT PRICE	TOTAL \$	UNIT PRICE	TOTAL \$		
	OPTION A											
1	PEA ROCK	4,000 TON	\$29.70	\$118,800.00	\$32.70	\$130,800.00	\$29.83	\$119,320.00				\$28.55
	PIT LOCATION		L.G. EVERIST - SUMMIT		SUMMIT, SD		JENSEN YARD - LG EVERIST					
	OPTION B											
2	PEA ROCK	-0- TON										\$0.00
	PIT LOCATION		L.G. EVERIST - ORTONVILLE		ORTONVILLE, MN		JENSEN YARD - LG EVERIST					
	OPTION C											
3	CRUSHED GRANITE	2,000 TON	\$51.50	\$103,000.00	\$53.25	\$106,500.00	\$49.75	\$99,500.00				\$45.00
	PIT LOCATION		L.G. EVERIST - ORTONVILLE		ORTONVILLE, MN		JENSEN YARD - LG EVERIST					
	OPTION D											
4	CRUSHED AGGREGATE	2,500 TON										\$0.00
	BASE COURSE						\$23.30	\$58,250.00	\$19.40	\$48,500.00		
	PIT LOCATION						JENSEN - WEST PIT		HALL SAND & GRAVEL			
	TOTAL BID		\$221,800.00		\$237,300.00		\$277,070.00		\$48,500.00			
	BID SURETY		10% BID BOND		10% BID BOND		10% BID BOND		N/A			

CERTIFIED BY: /s/ Jeromy Thorstenson

2/19/2026

BIDS RECIEVED FEBRUARY 17, 2026 - 2 PM AT ABERDEEN SOUTH DAKOTA

FOR AGGREGATES

NAME OF BIDDER -		ADDRESS OF BIDDER-		UNIT PRICE		TOTAL \$		UNIT PRICE		TOTAL \$		UNIT PRICE		TOTAL \$		UNIT PRICE		TOTAL \$		2025 BID PRICE
HF JACOBS & SON CONST.				PO BOX 36																
ABERDEEN, SD 57402-0036																				
ITEM	DESCRIPTION	UNIT		UNIT PRICE	TOTAL \$	UNIT PRICE	TOTAL \$	UNIT PRICE	TOTAL \$	UNIT PRICE	TOTAL \$	UNIT PRICE	TOTAL \$	UNIT PRICE	TOTAL \$	UNIT PRICE	TOTAL \$	UNIT PRICE	TOTAL \$	2025 BID PRICE
	OPTION A																			
1	PEA ROCK	4,000	TON	\$30.50	\$122,000.00		\$0.00		\$0.00		\$0.00		\$0.00		\$0.00		\$0.00		\$0.00	\$28.55
	PIT LOCATION			SUMMIT																
	OPTION B																			
2	PEA ROCK	-0-	TON																	\$0.00
	PIT LOCATION																			
	OPTION C																			
3	CRUSHED GRANITE	2,000	TON	\$48.00	\$96,000.00		\$0.00		\$0.00		\$0.00		\$0.00		\$0.00		\$0.00		\$0.00	\$45.00
	PIT LOCATION			FISHER MILBANK																
	OPTION D																			
4	CRUSHED AGGREGATE	2,500	TON																	\$0.00
	BASE COURSE			\$18.00	\$45,000.00		\$0.00		\$0.00		\$0.00		\$0.00		\$0.00		\$0.00		\$0.00	
	PIT LOCATION			JPIT																
TOTAL BID				\$263,000.00		\$0.00		\$0.00		\$0.00		\$0.00		\$0.00		\$0.00		\$0.00		
BID SURETY				CERTIFIED CHECK																

CERTIFIED BY: /s/ Jeromy Thorstenson

2/19/2026



City of Aberdeen

Council Agenda Memo

Agenda Item **7J**

Meeting Date:	2/23/2026	Department:	Public Works
Agenda Section:	New Business	Presented by:	Stu Nelson
Res./Ord. Number:	NA	Attachments:	1

Agenda Item Title:

Possible approval of 2026 Asphaltic Concrete and Surfacing Repair Mix Bid.

Proposed or Possible Action:

Motion and second to award the bid for 3/8” Bituminous Surfacing Repair Mix in the amount of \$17,500.00 (\$175.00/ton) to Duininck Inc. of Prinsburg, MN; and to award the bid for Asphaltic Concrete, Class D, Types I and II to Jensen Rock & Sand of Mobridge, SD and Lien Transportation Co. of Aberdeen, SD. Both suppliers submitted a bid for \$495,000.00 (\$90.00/ton).

Overview:

In the past, the Public Works Department has used both suppliers for the Class D Asphaltic Concrete Repair Mix, so given that the bids submitted are identical, the Public Works Department requests that the bid from both suppliers be accepted.

Financial Consideration:

2026 Special Sales Tax Budget

Attachments:

- 1. 1



City of Aberdeen

Council Agenda Memo

Agenda Item 7K

Meeting Date:	2/23/2026	Department:	Public Works
Agenda Section:	New Business	Presented by:	Stu Nelson
Res./Ord. Number:	NA	Attachments:	1

Agenda Item Title:

Possible approval of 2026 Road Oil Bid.

Proposed or Possible Action:

Motion and second to award the bid in the amount of \$507,655.50 (\$923.01 per ton of MC-3000) and \$27,396.00 (\$547.92 per ton of CSS1H-70:30) to Jebro, Inc. as lowest responsible bidder, and authorize the City Manager and Finance Officer to sign the necessary documents after approval by the City Attorney.

Overview:

NA

Financial Consideration:

2026 Special Sales Tax Budget

Attachments:

- 1

**BIDS RECIEVED FEBRUARY 17, 2026 - 2 PM AT ABERDEEN, SOUTH DAKOTA
FOR ROAD OIL**

NAME OF BIDDER -		JEBRO, INC.					2025 BID PRICE
ADDRESS OF BIDDER-		2303 BRIDGEPORT DRIVE					
		SIOUX CITY, IA 51111					
ITEM	DESCRIPTION	UNIT	UNIT PRICE	TOTAL \$	UNIT PRICE	TOTAL \$	UNIT PRICE
1.	MC - 3000	550 TONS	\$923.01	\$507,655.50			\$923.01
2.	CRS-2P	0 TONS					
3.	HFMS-2P	0 TONS					
4.	CSS1H-70:30	50 TONS	\$547.92	\$27,396.00			\$553.92

****NOTE: APPROXIMATELY 240 GALLONS/TON**

CERTIFIED BY: /s/ Jeromy Thorstenson

2/19/2026



City of Aberdeen

Council Agenda Memo

Agenda Item 7L

Meeting Date:	2/23/2026	Department:	Engineering
Agenda Section:	New Business	Presented by:	Destin Spellman Assistant Engineer
Res./Ord. Number:	NA	Attachments:	1

Agenda Item Title:

Possible approval of bid by CWF Concrete & Masonry of Aberdeen, SD in the amount of \$139,057.80 for project CONC-2026-1 (Annual Concrete Work).

Proposed or Possible Action:

Motion and second to approve bid.

Overview:

Two bids were received for the project. The Engineering Department recommends accepting the low bid by CWF Concrete & Masonry in the amount of \$139,057.80.

Financial Consideration:

NA

Attachments:

1. Bid Tabulation



City of Aberdeen

Council Agenda Memo

Agenda Item 7M

Meeting Date:	2/23/2026	Department:	Engineering
Agenda Section:	New Business	Presented by:	Destin Spellman Assistant Engineer
Res./Ord. Number:	NA	Attachments:	1

Agenda Item Title:

Possible approval of bid by CWF Concrete & Masonry of Aberdeen, SD in the amount of \$171,922.28 for project CONC-2026-2 (Accessible Sidewalk Quadrant Improvements).

Proposed or Possible Action:

Motion and second to approve bid.

Overview:

Three bids were received for the project. The Engineering Department recommends accepting the low bid by CWF Concrete & Masonry in the amount of \$171,922.28.

Financial Consideration:

NA

Attachments:

1. Bid Tabulation

ACCESSIBLE SIDEWALK QUADRANT IMPROVEMENTS

(Project CONC-2026-2)

BIDS RECEIVED FEBRUARY 17, 2026 @ 2 P.M. - ABERDEEN, SOUTH DAKOTA

NAME OF BIDDER - ADDRESS OF BIDDER-				Engineer's Estimate		J L Construction LLC PO Box 582 Sioux Falls, SD 57101		Wright & Sudlow Inc. PO Box 1782 Aberdeen, SD 57401		CWF Concrete 2724 392nd Ave S Aberdeen, SD 57401	
ITEM	DESCRIPTION	QUANTITY	UNITS								
1	Mobilization	1.00	LS	\$7,500.00	\$7,500.00	\$65,000.00	\$65,000.00	\$6,055.00	\$6,055.00	\$150.00	\$150.00
2	Distribute Public Notice Door Hangars	1.00	LS	\$250.00	\$250.00	\$3,500.00	\$3,500.00	\$1.00	\$1.00	\$1.00	\$1.00
3	Remove Concrete Surfacing	6,584.00	SF	\$1.50	\$9,876.00	\$5.00	\$32,920.00	\$1.50	\$9,876.00	\$1.40	\$9,217.60
4	Remove Existing Curb and Gutter	1,457.00	LF	\$4.25	\$6,192.25	\$5.00	\$7,285.00	\$4.00	\$5,828.00	\$4.00	\$5,828.00
5	Concrete Sawing	435.00	LF	\$1.50	\$652.50	\$15.00	\$6,525.00	\$1.00	\$435.00	\$1.00	\$435.00
6	Asphalt Sawing	2,263.00	LF	\$1.25	\$2,828.75	\$7.00	\$15,841.00	\$1.00	\$2,263.00	\$1.00	\$2,263.00
7	Remove Asphalt Surfacing	1,007.00	SY	\$5.75	\$5,790.25	\$5.00	\$5,035.00	\$5.85	\$5,890.95	\$5.80	\$5,840.60
8	Unclassified Excavation	335.00	CY	\$21.00	\$7,035.00	\$10.00	\$3,350.00	\$20.00	\$6,700.00	\$18.00	\$6,030.00
9	4" Concrete Sidewalk	7,893.00	SF	\$6.75	\$53,277.75	\$7.25	\$57,224.25	\$6.50	\$51,304.50	\$6.40	\$50,515.20
10	Install 24" Integral Curb and Gutter	1,426.00	LF	\$28.00	\$39,928.00	\$31.00	\$44,206.00	\$28.00	\$39,928.00	\$27.00	\$38,502.00
11	Gravel Cushion -2" Depth	147.00	Ton	\$24.00	\$3,528.00	\$30.00	\$4,410.00	\$18.00	\$2,646.00	\$22.00	\$3,234.00
12	Gravel Base Course -6" Depth	308.00	Ton	\$25.00	\$7,700.00	\$30.00	\$9,240.00	\$24.00	\$7,392.00	\$22.00	\$6,776.00
13	Detectable Warning Panels	620.00	SF	\$25.00	\$15,500.00	\$35.00	\$21,700.00	\$20.00	\$12,400.00	\$22.00	\$13,640.00
14	Asphalt Pavement Patching	1,094.00	SY	\$30.00	\$32,820.00	\$20.00	\$21,880.00	\$23.00	\$25,162.00	\$22.00	\$24,068.00
15	Expansion Joint Material	1,111.00	LF	\$1.00	\$1,111.00	\$1.25	\$1,388.75	\$0.50	\$555.50	\$0.58	\$644.38
16	Storm Inlet Adjustment	23.00	EA	\$150.00	\$3,450.00	\$350.00	\$8,050.00	\$25.00	\$575.00	\$10.00	\$230.00
17	Install Type "A" Storm Sewer Inlet w/Frame & Grate	2.00	EA	\$500.00	\$1,000.00	\$7,500.00	\$15,000.00	\$1,300.00	\$2,600.00	\$400.00	\$800.00
18	10" PVC Storm Sewer Lateral	30.00	LF	\$60.00	\$1,800.00	\$15.00	\$450.00	\$50.00	\$1,500.00	\$30.00	\$900.00
19	Sidewalk Closure	61.00	EA	\$50.00	\$3,050.00	\$150.00	\$9,150.00	\$1.00	\$61.00	\$20.00	\$1,220.00
20	Boulevard Restoration	3,255.00	SF	\$5.00	\$16,275.00	\$2.50	\$8,137.50	\$2.00	\$6,510.00	\$0.50	\$1,627.50
	BID SURETY					10% BB	10% BB	10% BB	10% BB		
	TOTAL BID			\$219,564.50		\$340,292.50		\$187,682.95		\$171,922.28	

Certified By: _____ /s/ Stuart Nelson

2/19/2026



City of Aberdeen

Council Agenda Memo

Agenda Item 7N

Meeting Date:	2/23/2026	Department:	Engineering
Agenda Section:	New Business	Presented by:	Destin Spellman Assistant Engineer
Res./Ord. Number:	NA	Attachments:	1

Agenda Item Title:

Possible approval of bid by Wright & Sudlow Inc. of Aberdeen, SD in the amount of \$238,351.00 for project CONC-2026-3 (Street Maintenance Concrete Repair 1).

Proposed or Possible Action:

Motion and second to approve bid.

Overview:

Two bids were received for the project. The Engineering Department recommends accepting the low bid by Wright & Sudlow Inc. in the amount of \$238,351.00.

Financial Consideration:

NA

Attachments:

1. Bid Tabulation



City of Aberdeen

Council Agenda Memo

Agenda Item 70

Meeting Date:	2/23/2026	Department:	Public Works
Agenda Section:	New Business	Presented by:	Stu Nelson Public Works Director
Res./Ord. Number:	NA	Attachments:	1

Agenda Item Title:

Possible approval of Recommendation on Bids for the Water Treatment Plant Pipe Gallery Valve Replacement Project

Proposed or Possible Action:

Motion and second to approve the above-referenced bid in the amount of \$664,900.00 from Hydro Tech Service of Pipestone, MN

Overview:

The purpose of this project is to replace all the valves and controls in the pipe gallery below the filter bays at the plant. This bid is substantially under the original estimate for the project of \$800,000.00 to \$1,000,000.00.

Financial Consideration:

Source of funds: Water Enterprise Fund

Attachments:

1. Bid Tabulation

**BIDS RECIEVED FEBRUARY 17, 2026 2PM AT ABERDEEN SOUTH DAKOTA
FOR 2026 WATER TREATMENT PLANT PIPE GALLERY VALVE REPLACEMENT**

NAME OF BIDDER -		HYDRO TECH SERVICE		
ADDRESS OF BIDDER -		PO BOX 303		
		PIPESTONE, MN 56164		
ITEM	DESCRIPTION			
1.	BASE BID	\$664,900.00		
	Labor & materials			
	BID SURETY	10% BB		

CERTIFIED BY: /s/ Stuart Nelson

2/19/2026



City of Aberdeen

Council Agenda Memo

Agenda Item **7P**

Meeting Date:	2/23/2026	Department:	Engineering
Agenda Section:	New Business	Presented by:	Destin Spellman Assistant Engineer
Res./Ord. Number:	NA	Attachments:	1

Agenda Item Title:

Possible approval of bid by Reede Construction Inc. of Aberdeen, SD in the amount of \$2,636,134.75 for project ST-2026-2 (North Dakota Street Reconstruction).

Proposed or Possible Action:

Motion and second to approve bid.

Overview:

Two bids were received for the project. The Engineering Department recommends accepting the low bid by Reede Construction Inc. in the amount of \$2,636,134.75.

Financial Consideration:

NA

Attachments:

1. Bid Tabulation

North Dakota Street Reconstruction (Project ST-2026-2)

BIDS RECEIVED February 17, 2026 @ 2 P.M. - ABERDEEN, SOUTH DAKOTA

NAME OF BIDDER -				Engineering's Estimate		Reede Construction, Inc.		BX Civil & Construction			
ADDRESS OF BIDDER-						5237 Hwy 12 E , Ste 1		PO Box 187			
						Aberdeen, SD 57401		Dell Rapids, SD 57022			
ITEM	DESCRIPTION	QUANTITY	UNITS	UNIT PRICE	TOTAL PRICE	UNIT PRICE	TOTAL PRICE	UNIT PRICE	TOTAL PRICE	UNIT PRICE	TOTAL PRICE
1	MOBILIZATION	1.0	LS	\$150,000.00	\$150,000.00	\$80,000.00	\$80,000.00	\$112,000.00	\$112,000.00		
2	TRAFFIC CONTROL	1.0	LS	\$25,000.00	\$25,000.00	\$16,000.00	\$16,000.00	\$25,000.00	\$25,000.00		
3	UNCLASSIFIED EXCAVATION	9,516.0	CY	\$8.00	\$76,128.00	\$6.50	\$61,854.00	\$7.00	\$66,612.00		
4	FILL EXCAVATED MATERIAL TO NEW ELEVATIONS	3,005.0	CY	\$2.50	\$7,512.50	\$4.50	\$13,522.50	\$5.00	\$15,025.00		
5	SALVAGE AND TRANSPORT EXCESS EXCAVATED MATERIAL	6,511.0	CY	\$2.00	\$13,022.00	\$4.50	\$29,299.50	\$15.00	\$97,665.00		
6	MILL AND SALVAGE EXISTING ASPHALT SURFACING FULL DEPTH	10,303.0	SY	\$2.25	\$23,181.75	\$3.25	\$33,484.75	\$5.00	\$51,515.00		
7	REMOVE AND DISPOSE EXISTING ASPHALT REC TRAIL	1,538.0	SY	\$3.50	\$5,383.00	\$4.00	\$6,152.00	\$4.00	\$6,152.00		
8	REMOVE AND DISPOSE EXISTING CULVERTS	3.0	EACH	\$500.00	\$1,500.00	\$1,900.00	\$5,700.00	\$1,000.00	\$3,000.00		
9	ADJUST EXISTING SANITARY MANHOLES TO NEW ROAD PROFILE	4.0	EACH	\$5,000.00	\$20,000.00	\$1,650.00	\$6,600.00	\$5,500.00	\$22,000.00		
10	REMOVE AND DISPOSE GRAVEL SUFACING	89.0	SY	\$1.50	\$133.50	\$3.00	\$267.00	\$9.00	\$801.00		
11	REMOVE AND DISPOSE ASPHALT STREET SURFACING	1,367.0	SY	\$4.00	\$5,468.00	\$4.00	\$5,468.00	\$5.00	\$6,835.00		
12	FULL DEPTH SAWCUTTING	2,447.0	LF	\$1.00	\$2,447.00	\$2.00	\$4,894.00	\$5.00	\$12,235.00		
13	REMOVE AND DISPOSE EXISTING CURB AND GUTTER	58.0	LF	\$3.50	\$203.00	\$3.00	\$174.00	\$7.00	\$406.00		
14	REMOVE AND DISPOSE EXISTING DRIVEWAY APRON	233.0	SF	\$1.50	\$349.50	\$3.50	\$815.50	\$2.00	\$466.00		
15	REMOVE, SALVAGE AND INSTALL EXISTING MAILBOXES AT USPS TEMP LOCATION	1.0	EACH	\$300.00	\$300.00	\$440.00	\$440.00	\$450.00	\$450.00		
16	INSTALL SALVAGED MAILBOXES AT NEW LOCATION	1.0	EACH	\$200.00	\$200.00	\$440.00	\$440.00	\$450.00	\$450.00		
17	FURNISH AND INSTALL 4" CONCRETE SIDEWALK	334.0	SF	\$6.25	\$2,087.50	\$5.50	\$1,837.00	\$10.00	\$3,340.00		
18	FURNISH AND INSTALL 5" CONCRETE RECREATION TRAIL	26,440.0	SF	\$6.75	\$178,470.00	\$5.50	\$145,420.00	\$8.00	\$211,520.00		
19	FURNISH AND INSTALL 8" CONCRETE FILLET SECTION	262.0	SY	\$126.00	\$33,012.00	\$115.00	\$30,130.00	\$185.00	\$48,470.00		
20	FURNISH AND INSTALL 6" CONCRETE APRONS	593.0	SF	\$7.25	\$4,299.25	\$7.50	\$4,447.50	\$9.00	\$5,337.00		
21	FURNISH AND INSTALL 8" PCC SURFACING	12,293.0	SY	\$72.00	\$885,096.00	\$77.00	\$946,561.00	\$75.00	\$921,975.00		
22	FURNISH AND INSTALL 24" CURB AND GUTTER	6,260.0	LF	\$27.00	\$169,020.00	\$20.00	\$125,200.00	\$20.00	\$125,200.00		
23	DRILL AND EPOXY DOWEL BARS	43.0	EACH	\$16.50	\$709.50	\$32.00	\$1,376.00	\$25.00	\$1,075.00		
24	FURNISH AND INSTALL DOWEL BARS	9,638.0	EACH	\$16.00	\$154,208.00	\$9.00	\$86,742.00	\$12.00	\$115,656.00		
25	FURNISH AND INSTALL TIE BARS	2,226.0	EACH	\$7.00	\$15,582.00	\$14.50	\$32,277.00	\$6.00	\$13,356.00		
26	DETECTABLE WARNING PANELS	310.0	SF	\$25.00	\$7,750.00	\$24.00	\$7,440.00	\$50.00	\$15,500.00		
27	ASPHALT PATCHING	416.0	TONS	\$125.00	\$52,000.00	\$150.00	\$62,400.00	\$150.00	\$62,400.00		
28	FURNISH AND INSTALL 4x4 INLET WITH TYPE B FRAME AND GRATE	10.0	EACH	\$4,000.00	\$40,000.00	\$8,650.00	\$86,500.00	\$7,800.00	\$78,000.00		
29	FURNISH AND INSTALL 2x3 INLET WITH TYPE B FRAME AND GRATE	12.0	EACH	\$3,700.00	\$44,400.00	\$4,600.00	\$55,200.00	\$4,300.00	\$51,600.00		
30	FURNISH AND INSTALL 48" CONCRETE STORM MANHOLE WITH FRAME AND COVER	6.0	EACH	\$6,500.00	\$39,000.00	\$6,500.00	\$39,000.00	\$5,800.00	\$34,800.00		
31	FURNISH AND INSTALL 18" STORM SEWER PIPE	1,050.0	LF	\$81.00	\$85,050.00	\$73.50	\$77,175.00	\$80.00	\$84,000.00		

32	FURNISH AND INSTALL 24" STORM SEWER PIPE	2,308.0	LF	\$98.00	\$226,184.00	\$86.00	\$198,488.00	\$100.00	\$230,800.00		
33	CONNECT TO EXISTING STORM PIPE	1.0	EACH	\$400.00	\$400.00	\$2,400.00	\$2,400.00	\$1,800.00	\$1,800.00		
34	FURNISH AND INSTALL 6" PVC WATERMAIN	47.0	LF	\$51.00	\$2,397.00	\$50.00	\$2,350.00	\$45.00	\$2,115.00		
35	FURNISH AND INSTALL 12" PVC WATERMAIN	6.0	LF	\$89.00	\$534.00	\$110.00	\$660.00	\$110.00	\$660.00		
36	FURNISH AND INSTALL 12x12x6 TEE	1.0	EACH	\$2,600.00	\$2,600.00	\$2,000.00	\$2,000.00	\$1,800.00	\$1,800.00		
37	FURNISH AND INSTALL 12" COUPLER	1.0	EACH	\$1,800.00	\$1,800.00	\$2,100.00	\$2,100.00	\$2,200.00	\$2,200.00		
38	FURNISH AND INSTALL 6" GATE VALVE	1.0	EACH	\$2,400.00	\$2,400.00	\$2,650.00	\$2,650.00	\$2,750.00	\$2,750.00		
39	FURNISH AND INSTALL 6" WATERMAIN CAP	1.0	EACH	\$800.00	\$800.00	\$440.00	\$440.00	\$600.00	\$600.00		
40	CONNECT TO EXISTING WATERMAIN	2.0	EACH	\$500.00	\$1,000.00	\$1,320.00	\$2,640.00	\$200.00	\$400.00		
41	FURNISH AND INSTALL 10" PVC SANITARY SEWER MAIN	82.0	LF	\$62.00	\$5,084.00	\$165.00	\$13,530.00	\$60.00	\$4,920.00		
42	FURNISH AND INSTALL 10" PVC CAP	1.0	EACH	\$400.00	\$400.00	\$440.00	\$440.00	\$350.00	\$350.00		
43	CONNECT TO EXISTING SANITARY MANHOLE	1.0	EACH	\$500.00	\$500.00	\$2,640.00	\$2,640.00	\$3,700.00	\$3,700.00		
44	FURNISH AND INSTALL 10" SDR 35 STORM LATERAL PIPE	853.0	LF	\$65.00	\$55,445.00	\$77.00	\$65,681.00	\$45.00	\$38,385.00		
45	FURNISH AND INSTALL 10" CONCRETE FLARED ENDS	2.0	EACH	\$500.00	\$1,000.00	\$750.00	\$1,500.00	\$550.00	\$1,100.00		
46	REMOVE, SALVAGE AND INSTALL EXISTING STORM SEWER INLET, FRAME, AND GRAT	1.0	EACH	\$400.00	\$400.00	\$3,000.00	\$3,000.00	\$2,000.00	\$2,000.00		
47	REMOVE, SALVAGE AND INSTALL EXISTING 18" STORM SEWER PIPE	37.0	LF	\$40.00	\$1,480.00	\$66.00	\$2,442.00	\$100.00	\$3,700.00		
48	FURNISH AND INSTALL GRAVEL BASECOURSE	7,114.0	TONS	\$22.00	\$156,508.00	\$23.00	\$163,622.00	\$35.00	\$248,990.00		
49	FURNISH AND INSTALL GEOTEXTILE SEPERATOR FABRIC	24,200.0	SY	\$3.00	\$72,600.00	\$2.80	\$67,760.00	\$3.00	\$72,600.00		
50	PAVEMENT JOINT SAWING AND SEALING	17,820.0	LF	\$1.75	\$31,185.00	\$2.10	\$37,422.00	\$4.00	\$71,280.00		
51	INLET PROTECTION	11.0	EACH	\$250.00	\$2,750.00	\$85.00	\$935.00	\$100.00	\$1,100.00		
52	SILT FENCE	36.0	LF	\$30.00	\$1,080.00	\$2.20	\$79.20	\$2.00	\$72.00		
53	REMOVE AND SALVAGE TOPSOIL	420.0	CY	\$2.00	\$840.00	\$5.50	\$2,310.00	\$20.00	\$8,400.00		
54	IMPORT CITY FURISHED MILLING FOR TEMP ROADS	300.0	SY	\$15.00	\$4,500.00	\$3.50	\$1,050.00	\$7.00	\$2,100.00		
55	TEMPORARY ROAD CONSTRUCTION	2,415.0	SY	\$9.50	\$22,942.50	\$4.40	\$10,626.00	\$2.00	\$4,830.00		
56	FURNISH AND INSTALL TEMPORARY 30" CULVERT	150.0	LF	\$40.00	\$6,000.00	\$77.00	\$11,550.00	\$1.50	\$225.00		
57	PERMENANT ACCESS ROAD CONSTRUCTION	7,600.0	SY	\$9.50	\$72,200.00	\$5.00	\$38,000.00	\$1.50	\$11,400.00		
58	SEEDING AND RESTORATION	5.8	AC	\$2,000.00	\$11,600.00	\$1,100.00	\$6,380.00	\$1,100.00	\$6,380.00		
59	IMPORT CITY FURNISHED TOPSOIL	2,408.0	CY	\$7.00	\$16,856.00	\$6.60	\$15,892.80	\$20.00	\$48,160.00		
60	HYDRO MULCH	5.8	AC	\$2,500.00	\$14,500.00	\$1,850.00	\$10,730.00	\$2,000.00	\$11,600.00		
								*Red denotes corrected error based on provided unit price			
	ADDENDUM #1 ACKNOWLEDGED							YES	YES		
	BID SURETY							10% BB	10% BB		
	TOTAL BID				\$2,757,498.00		\$2,636,134.75		\$2,977,258.00		

Certified By: _____ /s/ Stuart Nelson



City of Aberdeen

Council Agenda Memo

Agenda Item **8A**

Meeting Date:	2/23/2026	Department:	Finance
Agenda Section:	New Business	Presented by:	Jordan McQuillen Finance Officer
Res./Ord. Number:	NA	Attachments:	2

Agenda Item Title:

Bills list for February 23, 2026

Proposed or Possible Action:

Motion and second to approve payment of the Bills list for February 23, 2026, and any additions thereto, such bills having been audited by the Finance Officer and fully itemized and a memorandum of the same to be entered upon the minutes of the meeting, and to authorize the City Manager or acting City Manager to sign, and the Finance Officer to countersign, all warrants for payment of such approved bills. Council members may abstain regarding an identified claim and vote to approve the remainder of the Bills List.

Overview:

The Finance Officer submits the following Bills List for February 23, 2026, of vendors, items, or services purchased, or of claims made, and the amounts due thereon:

Bills Total: \$683,969.90

Financial Consideration:

NA

Attachments:

1. Itemized billing with totals
2. A/P Payment Register

CITY OF ABERDEEN

2025 BILLS PRESENTED - FEBRUARY 19, 2026 \$ 746.48

2026 BILLS PRESENTED - FEBRUARY 19, 2026 \$ 237,459.35

ADDITIONAL BILLS FEBRUARY 23, 2026

PAYEE	DESCRIPTION	AMOUNT
UTILITY	REFUNDS	\$ 114.07
UNITED PARCEL SERVICE	PARCEL PICKUP CHARGES MARCH 2026	\$ 1,000.00
ELAVON MERCHANT SERVICES	MERCH PROC FEES ONLINE PARKING MAR	\$ 500.00
PAYMENTECH LLC	MERCHANT FEES MARCH 2026	\$ 6,000.00
DACOTAH BANK	SERVICE CHG SYS-GEN MARCH 2026	\$ 150.00
NORTHERN ELECTRIC	UTILITIES	\$ 10,000.00
NORTHWESTERN ENERGY	UTILITIES	\$ 180,000.00
WELLMARK BCBS OF SD	WELLMARK ACH	\$ 248,000.00

TOTAL \$ 683,969.90



Bank: AP - ACCOUNTS PAYABLE

Vendor Number 14458	Vendor Name ABDN AREA HUMANE SOCIETY			Total Vendor Amount 6,400.00
Payment Type Check	Payment Number	Payment Date 02/19/2026	Payment Amount 6,400.00	
Payable Number MAR-2026	Description ANIMAL IMPOUND FEES - MARCH 2026	Payable Date 02/19/2026	Due Date 02/20/2026	Discount Amount 0.00
				Payable Amount 6,400.00

Vendor Number 12694	Vendor Name AQUA PURE INC			Total Vendor Amount 39,606.00
Payment Type Check	Payment Number	Payment Date 02/19/2026	Payment Amount 39,606.00	
Payable Number ABESD012926	Description 34,440 LBS AF 25150 POLYMER	Payable Date 02/19/2026	Due Date 02/20/2026	Discount Amount 0.00
				Payable Amount 39,606.00

Vendor Number 10360	Vendor Name AUTO VALUE - ABERDEEN			Total Vendor Amount 698.26
Payment Type Check	Payment Number	Payment Date 02/19/2026	Payment Amount 698.26	
Payable Number 445390306	Description SOLVENT & FILTERS	Payable Date 02/19/2026	Due Date 02/20/2026	Discount Amount 0.00
445390470	RELAY - #578	02/19/2026	02/20/2026	0.00
445390584	AC FLUSH KIT	02/19/2026	02/20/2026	0.00
445391257	GLOVES, FILTER, WIPER, CLEANER, FLOOR DRY	02/19/2026	02/20/2026	0.00
				Payable Amount 396.48

Vendor Number 11651	Vendor Name B&H PHOTO-VIDEO			Total Vendor Amount 329.98
Payment Type Check	Payment Number	Payment Date 02/19/2026	Payment Amount 329.98	
Payable Number 241728724	Description MOUNT-IT MOMI1772B	Payable Date 02/19/2026	Due Date 02/20/2026	Discount Amount 0.00
				Payable Amount 329.98

Vendor Number 11071	Vendor Name BANNER ASSOCIATES INC			Total Vendor Amount 57,990.66
Payment Type Check	Payment Number	Payment Date 02/19/2026	Payment Amount 57,990.66	
Payable Number 47404	Description CONST CONTRACT AGRMNT-JAN 2026 23932.00 WRF IM	Payable Date 02/19/2026	Due Date 02/20/2026	Discount Amount 0.00
				Payable Amount 57,990.66

Vendor Number 11705	Vendor Name BARRY DUNLAVY			Total Vendor Amount 112.00
Payment Type Check	Payment Number	Payment Date 02/19/2026	Payment Amount 112.00	
Payable Number 028-0211-BD	Description MEALS PER DIEM - ICC	Payable Date 02/19/2026	Due Date 02/20/2026	Discount Amount 0.00
				Payable Amount 112.00

Vendor Number 10466	Vendor Name BECK MOTORS INC			Total Vendor Amount 42,765.00
Payment Type Check	Payment Number	Payment Date 02/19/2026	Payment Amount 42,765.00	
Payable Number 2/12/2026	Description 2026 CHEVY SILVERADO 1500 4WD CREW CAB VIN0863	Payable Date 02/19/2026	Due Date 02/20/2026	Discount Amount 0.00
				Payable Amount 42,765.00

Payment Register

APPKT00483 - AGENDA 2.23.26 - 2026 BILLS

Vendor Number	Vendor Name					Total Vendor Amount
12785	BORNS GROUP					6,834.70
Payment Type	Payment Number			Payment Date		Payment Amount
Check				02/19/2026		6,834.70
Payable Number	Description	Payable Date	Due Date	Discount Amount	Payable Amount	
3076013026	SOLID WASTE UTIL BILLS POSTAGE	02/19/2026	02/20/2026	0.00	6,834.70	
10122	BROWN COUNTY LANDFILL					4.90
Payment Type	Payment Number			Payment Date		Payment Amount
Check				02/19/2026		4.90
Payable Number	Description	Payable Date	Due Date	Discount Amount	Payable Amount	
916064	RECLAMATION WASTE	02/19/2026	02/20/2026	0.00	4.90	
15609	BYTESPEED LLC					14,988.00
Payment Type	Payment Number			Payment Date		Payment Amount
Check				02/19/2026		14,988.00
Payable Number	Description	Payable Date	Due Date	Discount Amount	Payable Amount	
INV0183857	LENOVO THINKPAD E16 - 12	02/19/2026	02/20/2026	0.00	14,988.00	
15674	CHRISTIAN PONATH					504.00
Payment Type	Payment Number			Payment Date		Payment Amount
Check				02/19/2026		504.00
Payable Number	Description	Payable Date	Due Date	Discount Amount	Payable Amount	
01/26/2026	F) PER DIEM - SERTC HAZMAT TECH	02/19/2026	02/20/2026	0.00	504.00	
11706	CLIMATE CONTROL					780.56
Payment Type	Payment Number			Payment Date		Payment Amount
Check				02/19/2026		780.56
Payable Number	Description	Payable Date	Due Date	Discount Amount	Payable Amount	
81789393	SERVICED HD9A VOLTAGE CONVERSION SYS REJUVENATI	02/19/2026	02/20/2026	0.00	780.56	
11921	COAST TO COAST CALIBRATIONS INC					777.00
Payment Type	Payment Number			Payment Date		Payment Amount
Check				02/19/2026		777.00
Payable Number	Description	Payable Date	Due Date	Discount Amount	Payable Amount	
153220	SCALE, MICROSCOPE, HOOD CALIBRATION	02/19/2026	02/20/2026	0.00	777.00	
10274	COLE PAPERS INC					1,399.81
Payment Type	Payment Number			Payment Date		Payment Amount
Check				02/19/2026		1,399.81
Payable Number	Description	Payable Date	Due Date	Discount Amount	Payable Amount	
10682220	TOWELS, LINERS	02/19/2026	02/20/2026	0.00	212.20	
10682765	SPRAY BUFF, BATH TISSUE	02/19/2026	02/20/2026	0.00	335.09	
10684060	PAPER TOWELS	02/19/2026	02/20/2026	0.00	76.99	
10684114	PAPER TOWELS	02/19/2026	02/20/2026	0.00	143.25	
10684823	X) STATION SUPPLIES	02/19/2026	02/20/2026	0.00	632.28	
10757	CRAWFORD TRUCKS & EQUIP					2,847.60
Payment Type	Payment Number			Payment Date		Payment Amount
Check				02/19/2026		2,847.60
Payable Number	Description	Payable Date	Due Date	Discount Amount	Payable Amount	
01P72034	DEF LINE - #522	02/19/2026	02/20/2026	0.00	194.47	
01P72106.02	ALUM RIMS	02/19/2026	02/20/2026	0.00	2,120.00	
01P72172	CONTROL - #578	02/19/2026	02/20/2026	0.00	405.79	

Payment Register

APPKT00483 - AGENDA 2.23.26 - 2026 BILLS

01P72174	MOTOR & RESISTOR - #578	02/19/2026	02/20/2026	0.00	127.34
Vendor Number	Vendor Name				Total Vendor Amount
14245	CRESCENT ELECTRIC SUPPLY				420.23
Payment Type	Payment Number	Payment Date	Payment Amount		
Check		02/19/2026	420.23		
Payable Number	Description	Payable Date	Due Date	Discount Amount	Payable Amount
S513886164.001	HDS 400W	02/19/2026	02/20/2026	0.00	420.23
Vendor Number	Vendor Name				Total Vendor Amount
15926	DAKOTA ELECTRONICS LLC				5,017.95
Payment Type	Payment Number	Payment Date	Payment Amount		
Check		02/19/2026	5,017.95		
Payable Number	Description	Payable Date	Due Date	Discount Amount	Payable Amount
39426	2 NEW RADIOS & MICS PROGRAMMING	02/19/2026	02/20/2026	0.00	2,313.60
39427	RADIO INSTALL NEW DUMP TRUCK	02/19/2026	02/20/2026	0.00	905.90
39441	2 RADIO ANTENNAS	02/19/2026	02/20/2026	0.00	37.00
39463	REPLACE MIC JACK	02/19/2026	02/20/2026	0.00	225.00
39464	2 SPEAKER MICS	02/19/2026	02/20/2026	0.00	230.00
39467	REPROGRAM RADIO	02/19/2026	02/20/2026	0.00	55.00
39476	RADIO IN EXCAVATOR	02/19/2026	02/20/2026	0.00	988.45
39479	REPAIR MIC	02/19/2026	02/20/2026	0.00	28.00
39512	REPAIRED RADIO	02/19/2026	02/20/2026	0.00	55.00
39542	SIREN MONITORING - FEB 2026	02/19/2026	02/20/2026	0.00	180.00
Vendor Number	Vendor Name				Total Vendor Amount
12723	DAKOTA FLUID POWER INC				1,384.34
Payment Type	Payment Number	Payment Date	Payment Amount		
Check		02/19/2026	1,384.34		
Payable Number	Description	Payable Date	Due Date	Discount Amount	Payable Amount
7427814	CLAMPS	02/19/2026	02/20/2026	0.00	21.60
7428310	MACHINING SOCKETS	02/19/2026	02/20/2026	0.00	70.00
7428313	HYD HOSES - #555	02/19/2026	02/20/2026	0.00	1,033.86
7428992	HOSE - #524	02/19/2026	02/20/2026	0.00	153.88
7429559	CHECK HYD CYL - #555	02/19/2026	02/20/2026	0.00	105.00
Vendor Number	Vendor Name				Total Vendor Amount
11715	DAKOTA OUTDOORS				4,899.99
Payment Type	Payment Number	Payment Date	Payment Amount		
Check		02/19/2026	4,899.99		
Payable Number	Description	Payable Date	Due Date	Discount Amount	Payable Amount
020426114944697	VISION S60 ELLIPTICAL W/ LED CONSOLE	02/19/2026	02/20/2026	0.00	4,899.99
Vendor Number	Vendor Name				Total Vendor Amount
10633	DAKOTA SUPPLY GROUP				160.22
Payment Type	Payment Number	Payment Date	Payment Amount		
Check		02/19/2026	160.22		
Payable Number	Description	Payable Date	Due Date	Discount Amount	Payable Amount
S105403457.001	SEALS FOR BOOSTER STATION	02/19/2026	02/20/2026	0.00	160.22
Vendor Number	Vendor Name				Total Vendor Amount
11042	DAN WALDMAN				40.00
Payment Type	Payment Number	Payment Date	Payment Amount		
Check		02/19/2026	40.00		
Payable Number	Description	Payable Date	Due Date	Discount Amount	Payable Amount
292026	PER DIEM - SDRMCA CONCRETE	02/19/2026	02/20/2026	0.00	40.00

Payment Register

APPKT00483 - AGENDA 2.23.26 - 2026 BILLS

Vendor Number 11358	Vendor Name DEPENDABLE SANITATION					Total Vendor Amount 431.00
Payment Type Check	Payment Number			Payment Date 02/19/2026		Payment Amount 431.00
Payable Number 51038	Description GARBAGE SERVICE - FEB 2026	Payable Date 02/19/2026	Due Date 02/20/2026	Discount Amount 0.00		Payable Amount 202.00
7680/02-2026	SANITATION SERVICES - FEB 2026	02/19/2026	02/20/2026	0.00		229.00
Vendor Number 15830	Vendor Name DESTIN SPELLMAN					Total Vendor Amount 40.00
Payment Type Check	Payment Number			Payment Date 02/19/2026		Payment Amount 40.00
Payable Number 292026	Description PER DIEM - SDRMCA CONCRETE	Payable Date 02/19/2026	Due Date 02/20/2026	Discount Amount 0.00		Payable Amount 40.00
Vendor Number 14406	Vendor Name DIAMOND DRY CLEANING					Total Vendor Amount 248.88
Payment Type Check	Payment Number			Payment Date 02/19/2026		Payment Amount 248.88
Payable Number 202601-4845	Description F) CLASS A ALTERATIONS	Payable Date 02/19/2026	Due Date 02/20/2026	Discount Amount 0.00		Payable Amount 248.88
Vendor Number 10352	Vendor Name DIRECT AUTOMATION LLC					Total Vendor Amount 32.32
Payment Type Check	Payment Number			Payment Date 02/19/2026		Payment Amount 32.32
Payable Number INVDA000208	Description BATTERY BACKUP UPS - SHIPPING	Payable Date 02/19/2026	Due Date 02/20/2026	Discount Amount 0.00		Payable Amount 32.32
Vendor Number 15959	Vendor Name FIRE SAFETY FIRST					Total Vendor Amount 461.60
Payment Type Check	Payment Number			Payment Date 02/19/2026		Payment Amount 461.60
Payable Number 6074	Description 2 NEW FIRE EXTINGUISHERS & MOUNTS	Payable Date 02/19/2026	Due Date 02/20/2026	Discount Amount 0.00		Payable Amount 461.60
Vendor Number 14190	Vendor Name GEFFDOG DESIGNS					Total Vendor Amount 837.49
Payment Type Check	Payment Number			Payment Date 02/19/2026		Payment Amount 837.49
Payable Number 122804	Description ASST SHIRTS	Payable Date 02/19/2026	Due Date 02/20/2026	Discount Amount 0.00		Payable Amount 837.49
Vendor Number 14177	Vendor Name GRAINGER					Total Vendor Amount 1,688.01
Payment Type Check	Payment Number			Payment Date 02/19/2026		Payment Amount 1,688.01
Payable Number 9801152498	Description 1.5 HP SUMP PUMP	Payable Date 02/19/2026	Due Date 02/20/2026	Discount Amount 0.00		Payable Amount 1,688.01
Vendor Number 10634	Vendor Name GRAYMONT (WI) LLC					Total Vendor Amount 5,712.43
Payment Type Check	Payment Number			Payment Date 02/19/2026		Payment Amount 5,712.43
Payable Number 14-210870 RI	Description 24.59 TONS CALCIUM QUICKLIME	Payable Date 02/19/2026	Due Date 02/20/2026	Discount Amount 0.00		Payable Amount 5,712.43

Payment Register

APPKT00483 - AGENDA 2.23.26 - 2026 BILLS

Vendor Number	Vendor Name					Total Vendor Amount
11946	JARMAN'S WATER SYSTEMS					2,180.00
Payment Type	Payment Number			Payment Date	Payment Amount	
Check				02/19/2026	2,180.00	
Payable Number	Description	Payable Date	Due Date	Discount Amount	Payable Amount	
38094	50 LB BAGS WATER SOFTENER SALT	02/19/2026	02/20/2026	0.00	470.00	
38113	50 LBS WATER SOFTENER SALT	02/19/2026	02/20/2026	0.00	1,710.00	
Vendor Number	Vendor Name					Total Vendor Amount
11402	JOE FITZ					40.00
Payment Type	Payment Number			Payment Date	Payment Amount	
Check				02/19/2026	40.00	
Payable Number	Description	Payable Date	Due Date	Discount Amount	Payable Amount	
292026	PER DIEM - SDRMCA CONCRETE	02/19/2026	02/20/2026	0.00	40.00	
Vendor Number	Vendor Name					Total Vendor Amount
12804	KILLORAN TRUCKING & BROKERAGE					13,417.88
Payment Type	Payment Number			Payment Date	Payment Amount	
Check				02/19/2026	13,417.88	
Payable Number	Description	Payable Date	Due Date	Discount Amount	Payable Amount	
129584	24.22 TONS SODA ASH	02/19/2026	02/20/2026	0.00	13,417.88	
Vendor Number	Vendor Name					Total Vendor Amount
14461	LINDE GAS & EQUIP INC					240.64
Payment Type	Payment Number			Payment Date	Payment Amount	
Check				02/19/2026	240.64	
Payable Number	Description	Payable Date	Due Date	Discount Amount	Payable Amount	
54720763	TANK EX, GLOVES, CONE, DEFUSER, ETC	02/19/2026	02/20/2026	0.00	240.64	
Vendor Number	Vendor Name					Total Vendor Amount
13154	LOU'S GLOVES INC					182.00
Payment Type	Payment Number			Payment Date	Payment Amount	
Check				02/19/2026	182.00	
Payable Number	Description	Payable Date	Due Date	Discount Amount	Payable Amount	
061144	XL NITRILE GLOVES	02/19/2026	02/20/2026	0.00	182.00	
Vendor Number	Vendor Name					Total Vendor Amount
11260	MACQUEEN EMERGENCY GROUP					1,297.41
Payment Type	Payment Number			Payment Date	Payment Amount	
Check				02/19/2026	1,297.41	
Payable Number	Description	Payable Date	Due Date	Discount Amount	Payable Amount	
P62067	F) SCBA MASK FACE SHIELDS	02/19/2026	02/20/2026	0.00	1,297.41	
Vendor Number	Vendor Name					Total Vendor Amount
10501	MAC'S INC					118.47
Payment Type	Payment Number			Payment Date	Payment Amount	
Check				02/19/2026	118.47	
Payable Number	Description	Payable Date	Due Date	Discount Amount	Payable Amount	
305343/5	3/4 BREAKER, IMPACT SOCKET	02/19/2026	02/20/2026	0.00	107.98	
305405/5	BOLTS	02/19/2026	02/20/2026	0.00	10.49	
Vendor Number	Vendor Name					Total Vendor Amount
11941	MARIAH MOUGEY					54.00
Payment Type	Payment Number			Payment Date	Payment Amount	
Check				02/19/2026	54.00	
Payable Number	Description	Payable Date	Due Date	Discount Amount	Payable Amount	
01/20/2026	A) PER DIEM - SDAA CONFERENCE	02/19/2026	02/20/2026	0.00	54.00	

Payment Register

Vendor Number 15619	Vendor Name MATT HILL					Total Vendor Amount 112.00
Payment Type Check	Payment Number			Payment Date 02/19/2026		Payment Amount 112.00
Payable Number 028-0211-MH	Description MEALS PER DIEM - ICC	Payable Date 02/19/2026	Due Date 02/20/2026	Discount Amount 0.00		Payable Amount 112.00
Vendor Number 13361	Vendor Name MATT PARROTT					Total Vendor Amount 1,737.20
Payment Type Check	Payment Number			Payment Date 02/19/2026		Payment Amount 1,737.20
Payable Number PINV1305935	Description CMS LS FS CHECKS QYT-11,000	Payable Date 02/19/2026	Due Date 02/20/2026	Discount Amount 0.00		Payable Amount 1,737.20
Vendor Number 12043	Vendor Name MCMASTER-CARR SUPPLY CO					Total Vendor Amount 70.33
Payment Type Check	Payment Number			Payment Date 02/19/2026		Payment Amount 70.33
Payable Number 59190605	Description 36 MM IMPACT SOCKETS	Payable Date 02/19/2026	Due Date 02/20/2026	Discount Amount 0.00		Payable Amount 70.33
Vendor Number 12508	Vendor Name MENARDS INC					Total Vendor Amount 281.06
Payment Type Check	Payment Number			Payment Date 02/19/2026		Payment Amount 281.06
Payable Number 52715	Description LAUNDRY DETERGENT, BRUSH, CONDUIT	Payable Date 02/19/2026	Due Date 02/20/2026	Discount Amount 0.00		Payable Amount 80.74
52875	BREAK ROOM SUPPLIES	02/19/2026	02/20/2026	0.00		18.94
52884	COUPLINGS & PLUGS	02/19/2026	02/20/2026	0.00		15.94
52932	SAFETY TRAINING EQUIP INSTALL SUPPLIES	02/19/2026	02/20/2026	0.00		33.33
52933	BREAK ROOM SUPPLIES	02/19/2026	02/20/2026	0.00		120.65
52978	SAFETY TRAINING EQUIP INSTALL SUPPLIES	02/19/2026	02/20/2026	0.00		11.46
Vendor Number 16013	Vendor Name MID CONTINENT TESTING LAB INC					Total Vendor Amount 120.00
Payment Type Check	Payment Number			Payment Date 02/19/2026		Payment Amount 120.00
Payable Number 137603	Description WATER TESTING - JAN 2026	Payable Date 02/19/2026	Due Date 02/20/2026	Discount Amount 0.00		Payable Amount 120.00
Vendor Number 10650	Vendor Name MIDSTATES GROUP					Total Vendor Amount 1,733.00
Payment Type Check	Payment Number			Payment Date 02/19/2026		Payment Amount 1,733.00
Payable Number N492947	Description DOOR HANGERS - METER DEPARTMENT	Payable Date 02/19/2026	Due Date 02/20/2026	Discount Amount 0.00		Payable Amount 1,129.00
N493555	SWAB COLLECTION ENVELOPES	02/19/2026	02/20/2026	0.00		485.00
N494203	MIKE HEPOLA BUSINESS CARDS	02/19/2026	02/20/2026	0.00		119.00
Vendor Number 15842	Vendor Name MIKE HEPOLA					Total Vendor Amount 112.00
Payment Type Check	Payment Number			Payment Date 02/19/2026		Payment Amount 112.00
Payable Number 028-0211-MH	Description MEALS PER DIEM - ICC	Payable Date 02/19/2026	Due Date 02/20/2026	Discount Amount 0.00		Payable Amount 112.00

Payment Register

APPKT00483 - AGENDA 2.23.26 - 2026 BILLS

Vendor Number 12001	Vendor Name MTI DISTRIBUTING					Total Vendor Amount 547.71
Payment Type Check	Payment Number		Payment Date 02/19/2026	Payment Amount 547.71		
Payable Number 1507309-00	Description BLADES, WHEEL ASSEMBLY, SCREWS	Payable Date 02/19/2026	Due Date 02/20/2026	Discount Amount 0.00	Payable Amount 547.71	
Vendor Number 12916	Vendor Name NCL OF WISCONSIN					Total Vendor Amount 979.45
Payment Type Check	Payment Number		Payment Date 02/19/2026	Payment Amount 979.45		
Payable Number 531328	Description TNT830, TNT832 AMMONIA, TNT872 VOLATILE	Payable Date 02/19/2026	Due Date 02/20/2026	Discount Amount 0.00	Payable Amount 979.45	
Vendor Number 16015	Vendor Name OHD LLLP					Total Vendor Amount 970.00
Payment Type Check	Payment Number		Payment Date 02/19/2026	Payment Amount 970.00		
Payable Number 108939	Description F) QUANTI FIT 2 CALIBRATION	Payable Date 02/19/2026	Due Date 02/20/2026	Discount Amount 0.00	Payable Amount 970.00	
Vendor Number 11223	Vendor Name OLSON'S PEST TECHNICIANS					Total Vendor Amount 410.00
Payment Type Check	Payment Number		Payment Date 02/19/2026	Payment Amount 410.00		
Payable Number 509659	Description LEEVE PEST CONTROL MTHLY SVC	Payable Date 02/19/2026	Due Date 02/20/2026	Discount Amount 0.00	Payable Amount 410.00	
Vendor Number 15768	Vendor Name ONSITE SERVICE SOLUTIONS LLC					Total Vendor Amount 3,845.00
Payment Type Check	Payment Number		Payment Date 02/19/2026	Payment Amount 3,845.00		
Payable Number 12015	Description CALIBRATE & SERVICE SENSORS	Payable Date 02/19/2026	Due Date 02/20/2026	Discount Amount 0.00	Payable Amount 3,845.00	
Vendor Number 10178	Vendor Name OVERHEAD DOOR BROWN CO-ABDN					Total Vendor Amount 306.12
Payment Type Check	Payment Number		Payment Date 02/19/2026	Payment Amount 306.12		
Payable Number 26625-IN	Description REPAIR GARAGE DOOR OPENER	Payable Date 02/19/2026	Due Date 02/20/2026	Discount Amount 0.00	Payable Amount 306.12	
Vendor Number 10264	Vendor Name PERFORMANCE OIL & LUBRICANTS					Total Vendor Amount 2,307.95
Payment Type Check	Payment Number		Payment Date 02/19/2026	Payment Amount 2,307.95		
Payable Number 111298	Description 417.70 GAL #2 ULS DYED PREM	Payable Date 02/19/2026	Due Date 02/20/2026	Discount Amount 0.00	Payable Amount 1,187.52	
Payable Number 111299	Description 394.10 GAL #2 ULS DYED PREM	Payable Date 02/19/2026	Due Date 02/20/2026	Discount Amount 0.00	Payable Amount 1,120.43	
Vendor Number 15671	Vendor Name PLATINUM AUTO SPA					Total Vendor Amount 24.00
Payment Type Check	Payment Number		Payment Date 02/19/2026	Payment Amount 24.00		
Payable Number 01/2026	Description CAR WASHES - JAN 2026	Payable Date 02/19/2026	Due Date 02/20/2026	Discount Amount 0.00	Payable Amount 24.00	

Payment Register

Vendor Number	Vendor Name					Total Vendor Amount
10121	RDO EQUIPMENT CO					4,995.00
Payment Type	Payment Number			Payment Date	Payment Amount	
Check				02/19/2026	4,995.00	
Payable Number	Description	Payable Date	Due Date	Discount Amount	Payable Amount	
P9532551	PRO SERVICE	02/19/2026	02/20/2026	0.00	4,995.00	
Vendor Number	Vendor Name					Total Vendor Amount
15404	RUNNINGS SUPPLY INC #14					716.90
Payment Type	Payment Number			Payment Date	Payment Amount	
Check				02/19/2026	716.90	
Payable Number	Description	Payable Date	Due Date	Discount Amount	Payable Amount	
8266010	DEWALT IMPACT	02/19/2026	02/20/2026	0.00	279.00	
8267054	1/4 IMPACT DRIVER KIT, METRIC WRENCH SET	02/19/2026	02/20/2026	0.00	225.99	
8270181	DYE, PIPE, WRENCH SET	02/19/2026	02/20/2026	0.00	61.97	
8270477	GLOVES	02/19/2026	02/20/2026	0.00	99.95	
8270862	JACK	02/19/2026	02/20/2026	0.00	49.99	
Vendor Number	Vendor Name					Total Vendor Amount
10968	SD DEPT OF AG & NAT RES					250.00
Payment Type	Payment Number			Payment Date	Payment Amount	
Check				02/19/2026	250.00	
Payable Number	Description	Payable Date	Due Date	Discount Amount	Payable Amount	
SDR10P5IG	STORMWATER CONSTRUCTION	02/19/2026	02/20/2026	0.00	250.00	
Vendor Number	Vendor Name					Total Vendor Amount
10535	SEWER DUCK INC					200.00
Payment Type	Payment Number			Payment Date	Payment Amount	
Check				02/19/2026	200.00	
Payable Number	Description	Payable Date	Due Date	Discount Amount	Payable Amount	
72697	X) ST 1 KITCHEN SINK DRAIN	02/19/2026	02/20/2026	0.00	200.00	
Vendor Number	Vendor Name					Total Vendor Amount
11783	STACY VRCHOTA					40.18
Payment Type	Payment Number			Payment Date	Payment Amount	
Check				02/19/2026	40.18	
Payable Number	Description	Payable Date	Due Date	Discount Amount	Payable Amount	
02/09/2026	F) REIM-UBER FDSOA CONFERENCE	02/19/2026	02/20/2026	0.00	40.18	
Vendor Number	Vendor Name					Total Vendor Amount
11555	STOP STICK LTD					1,676.00
Payment Type	Payment Number			Payment Date	Payment Amount	
Check				02/19/2026	1,676.00	
Payable Number	Description	Payable Date	Due Date	Discount Amount	Payable Amount	
0041565-IN	3 9" STOP STICK KIT W/TRAY	02/19/2026	02/20/2026	0.00	1,676.00	
Vendor Number	Vendor Name					Total Vendor Amount
15705	UNIFORM CENTER					740.43
Payment Type	Payment Number			Payment Date	Payment Amount	
Check				02/19/2026	740.43	
Payable Number	Description	Payable Date	Due Date	Discount Amount	Payable Amount	
323067-1	X) YEARS OF SERVICE PINS	02/19/2026	02/20/2026	0.00	195.48	
324223-1	X) FF BADGES	02/19/2026	02/20/2026	0.00	544.95	
Vendor Number	Vendor Name					Total Vendor Amount
15485	VERIZON WIRELESS					341.69
Payment Type	Payment Number			Payment Date	Payment Amount	
Check				02/19/2026	341.69	
Payable Number	Description	Payable Date	Due Date	Discount Amount	Payable Amount	
6135379872	AIRPORT 24HR LINE 605.216.0321	02/19/2026	02/20/2026	0.00	341.69	

Payment Summary

Bank Code	Type	Payable Count	Payment Count	Discount	Payment
AP	Check	99	60	0.00	237,459.35
Packet Totals:		99	60	0.00	237,459.35

Cash Fund Summary

Fund	Name	Amount
999	POOL CASH	-237,459.35
Packet Totals:		-237,459.35



City of Aberdeen, SD

Payment Register

APPKT00482 - AGENDA 2.23.26 - 2025 BILLS
01 - City of Aberdeen

Bank: AP - ACCOUNTS PAYABLE

Vendor Number	Vendor Name						Total Vendor Amount
13064	MATHESON TRI-GAS INC						62.53
Payment Type	Payment Number					Payment Date	Payment Amount
Check						02/19/2026	62.53
	Payable Number	Description	Payable Date	Due Date	Discount Amount	Payable Amount	
	32819708	OXYGEN	02/19/2026	02/20/2026	0.00	62.53	
Vendor Number	Vendor Name						Total Vendor Amount
13276	PREMIER SPECIALTY VEHICLES						438.95
Payment Type	Payment Number					Payment Date	Payment Amount
Check						02/19/2026	438.95
	Payable Number	Description	Payable Date	Due Date	Discount Amount	Payable Amount	
	1005735	A) MEDIC 1 PT COMPARTMENT LIGHT	02/19/2026	02/20/2026	0.00	438.95	
Vendor Number	Vendor Name						Total Vendor Amount
10344	TDS MEDIA DIRECT INC						245.00
Payment Type	Payment Number					Payment Date	Payment Amount
Check						02/19/2026	245.00
	Payable Number	Description	Payable Date	Due Date	Discount Amount	Payable Amount	
	36590	ADVERTISING - AMERICINN HOTEL	02/19/2026	02/20/2026	0.00	245.00	

Payment Summary

Bank Code	Type	Payable Count	Payment Count	Discount	Payment
AP	Check	3	3	0.00	746.48
Packet Totals:		3	3	0.00	746.48

Cash Fund Summary

Fund	Name	Amount
999	POOL CASH	-746.48
Packet Totals:		-746.48