



**Beverly Hills City Council Liaison /  
OpenBH Design and Operating Standards Ad Hoc Committee  
will conduct a Special Meeting, at the following time and place, and will address the  
agenda listed below:**

**CITY OF BEVERLY HILLS  
455 N. Rexford Drive  
Room 280A  
Beverly Hills, CA 90210**

**IN PERSON / TELEPHONIC / VIDEO CONFERENCE MEETING**

**Beverly Hills Liaison Meeting  
<https://beverlyhills-org.zoom.us/my/committee>  
Meeting ID: 516 191 2424  
Passcode: 90210**

**You can also dial in by phone:  
+1 669 900 9128 US  
+1 833 548 0282 (Toll-Free)**

**One tap mobile  
+16699009128,,5161912424# US  
+18335480282,,5161912424# US (Toll-Free)**

**Tuesday, March 28, 2023  
11:00 AM**

***Please be advised that pre-entry metal detector screening requirements are now in place in City Hall. Members of the public are requested to plan visits accordingly.***

*In the interest of maintaining appropriate social distancing, members of the public can view this meeting through live webcast at [www.beverlyhills.org/live](http://www.beverlyhills.org/live) and on BH Channel 10 or Channel 35 on Spectrum Cable, and can participate in the teleconference/video conference by using the link above. Written comments may be emailed to [mayorandcitycouncil@beverlyhills.org](mailto:mayorandcitycouncil@beverlyhills.org) and will also be taken during the meeting when the topic is being reviewed by the Beverly Hills City Council Liaison / OpenBH Design and Operating Standards Ad Hoc Committee. Beverly Hills Liaison meetings will be in-person at City Hall.*

#### **AGENDA**

- 1) Public Comment
  - a. Members of the public will be given the opportunity to directly address the Committee on any item listed on the agenda.
  
- 2) Open BH Design and Operating Standards Subcommittee Stakeholder and Liaison Workshop #5
  - a. Summary of the Path in Developing Design Guidelines

- b. Draft Design Guidelines
- c. Updates on Outreach Meetings
- d. Large Group Q & A
- e. Next Steps / Timelines

3) Future Agenda Items

4) Adjournment



**Huma Ahmed**  
**City Clerk**

**Posted: March 23, 2023**

**A DETAILED LIAISON AGENDA PACKET IS AVAILABLE FOR REVIEW AT  
[WWW.BEVERLYHILLS.ORG](http://WWW.BEVERLYHILLS.ORG)**



Pursuant to the Americans with Disabilities Act, the City of Beverly Hills will make reasonable efforts to accommodate persons with disabilities. If you require special assistance, please call (310) 285-1014 (voice) or (310) 285-6881 (TTY). Providing at least twenty-four (24) hours advance notice will help to ensure availability of services. City Hall, including Room 280A, is wheelchair accessible.



## CITY OF BEVERLY HILLS -

### MEMORANDUM

**TO:** Beverly Hills City Council OpenBH  
Design and Operating Standards Subcommittee

**FROM:** Shana Epstein, Director of Public Works  
Daren Grilley, Assistant Director of Public Works, City Engineer  
Mandana Motahari, City Architect  
Laura Biery, Marketing and Economic Sustainability Manager

**DATE:** March 28, 2023

**SUBJECT:** OpenBH Design and Operating Standards Subcommittee Meeting

**ATTACHMENT:** Draft Parklet Design Guidelines  
Stakeholders Recent Outreach Result - What We Heard

---

#### **INTRODUCTION**

This memorandum will provide Councilmembers assigned to the OpenBH Design and Operating Standards Subcommittee (Subcommittee) with an outline of the discussion points for today's meeting. This is the fifth meeting in a series of stakeholder outreach meetings which began in May of 2022. Today's meeting will be a discussion of the work completed to date, and a review of the draft Design Guidelines. This outreach will include the involvement of stakeholders that are both currently OpenBH participants and non-participants. Future outreach will include developing a sample interactive parklet mockup and finalizing Parklet Design Guidelines.

#### **DISCUSSION**

##### **Background**

OpenBH was created to keep all Beverly Hills businesses open during the pandemic, including but not limited to restaurants and cafés. These businesses were permitted to install open-air dining as a temporary solution to help them stay operational during a time when indoor dining was not allowed. OpenBH installations by restaurants and cafés include sidewalk dining, converted private property dining (parking lots), and parklet dining (dining in parking meter spaces or similar). For the purposes of this Subcommittee discussion, and to clarify the scope of work of the architectural team, the draft Design Guidelines focus only on parklet dining. As a reminder, the parklets that were installed during the pandemic were intended to be a temporary solution; constructed quickly and with easy to assemble materials in an urgent effort to meet the need for additional outdoor dining space. The current parklets often reflect the unique character and aesthetic quality of each business however, overall street aesthetics are not harmonious and

Meeting Date: March 28, 2023

cohesive. With the desire to make these temporary installations more permanent, parklets need to be inviting and create people-oriented spaces that are both functional, and aesthetically enhancing to the overall streetscape. To achieve this goal, developing a set of minimum design standards is warranted and can be reinforced with consideration to the Beverly Hills brand.

At the direction of the City Council, two Ad Hoc Subcommittees have been formed to work on the long-term conversion of the OpenBH program to include permanent outdoor dining. The Subcommittees include:

- Design and Operating Standards Sub Committee
- Code and Fee Changes Subcommittee

The focus of the Design and Operating Standards Subcommittee is to develop design and operational standards for OpenBH participants (primarily parklet uses).

### **Overview of previous meetings**

At The kickoff meeting on May 25<sup>th</sup>, 2022, the Subcommittee discussed project goals and objectives, as well as how to set up a path for developing design standards. Since then, the Subcommittee has conducted four hybrid workshops (in-person with virtual option) that were held on June 13<sup>th</sup>, 2022, August 17<sup>th</sup>, 2022, December 12<sup>th</sup>, 2022 and February 9<sup>th</sup>, 2023. Survey questions were developed to reflect topics that were discussed in the first stakeholder workshop and posted online for community feedback in July 2022.

The second workshop focused on survey results and what was heard as emerging themes, continued conversation with stakeholders discussing project parameters and an outline of design guidelines.

In order to allow community members who missed the meetings a chance to participate, the survey questions were posted for a second time in September 2022, thereby obtaining additional feedback. A total of 187 residents and 12 business owners who participated gave their feedback on topics which included street location, parklet envelope (footprint and height), design elements, materials, parklet components, operations and maintenance.

At the third stakeholder meeting, highlights of previous meetings were presented followed by sharing what was heard. With a focus on the emerging themes of site and design strategies, a path forward to the development of standards was established. The meeting also included a small group workshop for an in-depth approach to storefront dining & parklets, as well as an evaluation of design opportunities arising from using planters to create safety barriers, screening and other parklet components. At the direction of Council Liaisons, City staff were tasked with additional outreach efforts which included individual in-person meetings with all restaurant businesses currently using parklets.

Staff met with the then 28 restaurant businesses with parklets, and reviewed an in-depth approach to create parameters in the design standards that address site strategies such as footprint, height, aesthetics and safety. Note that since the outreach began, an additional business has removed its parklet bringing the current number to 27 restaurant businesses with parklets. The stakeholder's main concerns were regarding the potential costs (fees and construction cost), as well as any reduction in square footage of the parklets compared to the current sizes. Furthermore, the stakeholders who have invested multiple times in improving their parklets voiced concern about the cost of further potential modifications to their current installations.

Meeting Date: March 28, 2023

The fourth stakeholder meeting focused on updates from on-site outreach meetings, a review of outdoor dining variations and case studies, as well as a presentation and small group workshop discussion about the 'kit of parts' materials and landscape palettes. It was emphasized that the proposed 'kit of parts' will be made available to stakeholders if they chose to use a pre-approved system for construction. The guidelines will however allow for both custom designs, as well as a path to streamline and expedite the administrative approval process.

Since the last stakeholders meeting, staff have conducted three additional outreach meetings to review the draft Parklet Design Guidelines with the current parklet participants and collect their input before finalizing the Guidelines. City and Chamber of Commerce staff also dropped off a printed copy of the draft Parklet Design Guidelines to each of the now existing 27 parklet businesses.

### **Public Outreach**

Public outreach efforts conducted by staff throughout this process has been provided by a variety of means including in-person meetings, virtual meetings, social media postings, direct emails to all OpenBH parklet participants, advertisement in the Beverly Hills Courier and Beverly Hills Weekly, as well as Spotlight in the Beverly Hills Chambers newsletter.

### **Development of Design Standards and Program Implementations**

During the process of developing Parklets Design Standards for outdoor dining, stakeholders have been fully involved and engaged through multiple workshops, surveys and in-person meetings. The following outlines emerging themes based on Surveys and workshops feedback;

- *Parklets should be regulated by factors like business frontage and vehicular visibility*
- *Pedestrian paths should be distinct and unobstructed*
- *Umbrellas and canopies shall provide generous clear head height*
- *Greenery improves the streetscape & dining experience, using landscaping should be encouraged*
- *Parklet components should meet high design standards*
- *Design guidelines should prioritize flexibility*
- *Safety components should be integrated into design & not outwardly visible*
- *Safety features should be available as both a ready-made product or a custom option integral to the design*
- *Canopies are essential to diner comfort and flexible shading system are preferable*
- *Some visibility from street to storefronts should be maintained*

Unlike storefront open air dining, a parklet has an immediate interface with vehicular traffic and therefore safety is the number one goal of the standards, followed by a desire to value upscale aesthetics consistent with the Beverly Hills brand. The Design Guidelines provide standards to provide diner, pedestrian, and vehicular comfort while supporting the overall aesthetic of the streetscape reinforcing vibrancy of pedestrian activities and storefronts visibility.

For considerations to stakeholders who have invested in reconstruction or the continual upkeep of their original parklets, there will be a glide path created that includes city review with a discretionary process to ensure the installations meet the intent of the guidelines.

For today's meeting, Lorcan O'Herlihy Architects will present the major topics of the guidelines, with a refresher on the path taken to develop the guidelines, and present the structure of the draft design guidelines. In addition, City staff will provide an update on the result of recent outreach in reviewing the draft booklet.

Today's agenda includes:

Meeting Date: March 28, 2023

- Summary of the Path in Developing Design Guidelines
- Draft Design Guidelines
- Updates on Outreach Meetings
- Large Group Q & A
- Next Steps
- Timeline

### **FISCAL IMPACT**

There are no fiscal impacts at this time. Fiscal impacts will be evaluated at future meetings based on project development and recommendations made by the Subcommittee. It should be noted the OpenBH Code and Fee Changes Subcommittee is meeting separately to discuss the fee schedule for the long term open air dining program. Last meeting was held on March 14, 2023.

### **RECOMMENDATION**

Design Standards will not be finalized until stakeholder input and feedback has been discussed. Staff recommends that the Subcommittee discuss the results of findings from the last stakeholder outreach meetings and comment on items as outlined below:

- Based on draft document presented, should staff continue to finalize the Design Guidelines?
- Is it acceptable to use a Glide Path to implement guidelines on current parklets?

The next stakeholder meeting will discuss 'Kit of Parts' fabrication costs and stakeholder's feedback on the interactive Mockup set to be constructed in May 2023.

# **Attachment 1**

**DRAFT**

City of Beverly Hills

**PARKLET DESIGN  
GUIDELINES**



**2023**

# INTRODUCTION

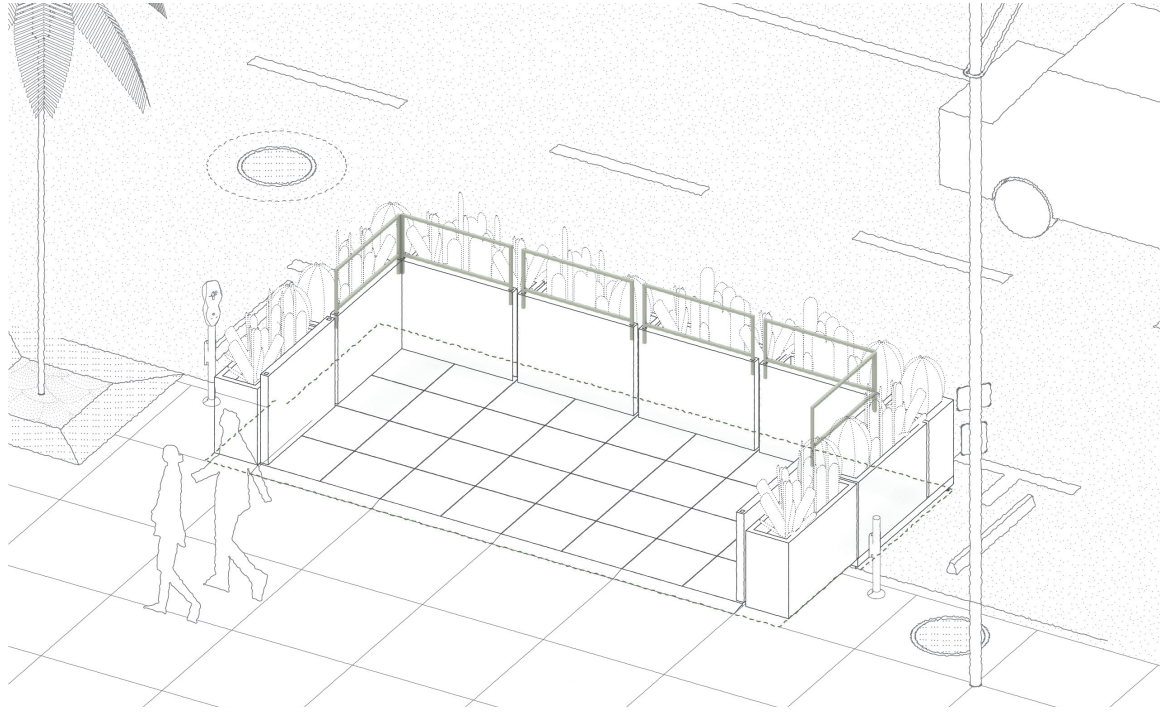

## What is a Parklet?

A Parklet is any space where street parking is converted to an outdoor dining area to serve an adjacent restaurant business. Unlike storefront open air dining, described within, a parklet has an immediate interface with vehicular traffic. Parklets, therefore, require a more robust set of technical standards defined within this manual.

## The History of Parklets in Beverly Hills

Parklet installations during the pandemic were built to meet the urgent temporary need for additional outdoor space. OpenBH was created to help all Beverly Hills businesses to be open during the pandemic. One of the more popular uses of the OpenBH program was by restaurants and cafés who were permitted to provide open-air dining as a temporary solution to help them stay operational during a time when outdoor dining was the only available option. OpenBH installations by restaurants and cafes include sidewalk dining, converted private property dining (parking lots), and parklet dining (dining in parking meter spaces or similar). With the desire to make these temporary installations more permanent, parklets need to provide diner, pedestrian, and vehicular comfort while supporting the overall aesthetic of the streetscape. To achieve this goal, these parklet design guidelines were developed with considerations to the Beverly Hills brand.

At the direction of the City Council, two Ad Hoc Subcommittees were formed to work on the long-term conversion of the OpenBH program for outdoor dining. The Subcommittees include; “Design and Operating Standards Subcommittee” and “Code and Fee Changes Subcommittee”. Together these committees collaborated with stakeholders, business owners and operators, City Council, technical experts, and the citizens of Beverly Hills to form the standards and design guidelines presented in this manual.

# ABOUT THE MANUAL

The Parklet Guidelines are organized by topic. Each topic provides a diagram and design standards section that lists the requirements for that item.

Within most topics, a kit of parts design has been provided inside of a green frame. This kit of parts approach is optional, however, it has been previously vetted with all city agencies to provide a more streamlined approval process.

## SECTION TITLE

## SECTION NO.

## SECTION DESCRIPTION

The section description identifies whether a section is essential for operation or if it is supplementary. All essential sections must be met for an application to be considered complete.

## SECTION DIAGRAM

A generic illustration of the various parklet elements. This illustration is intended only for demonstration purposes.

## TOPIC NUMBER

## CHECKLIST ITEM

The checklist identifies the relevant information to include in a parklet application.

## DESIGN STANDARDS

Essential standards that all parklets must meet.

## KIT-OF-PARTS

Use of the kit-of-parts is optional. The kit-of-parts is a pre-designed, adjustable set of building blocks that have been approved by the City of Beverly Hills to streamline the parklet design and application process.

2.3

# BARRIER



Oles et preputit est mil invel eicid ut ut maximet maio tene verit, totat pore eum qui tes dunt re omnissimus acepudandae. Itatem qui bea inciam qui cumquia quisciatquae et reheni vel.

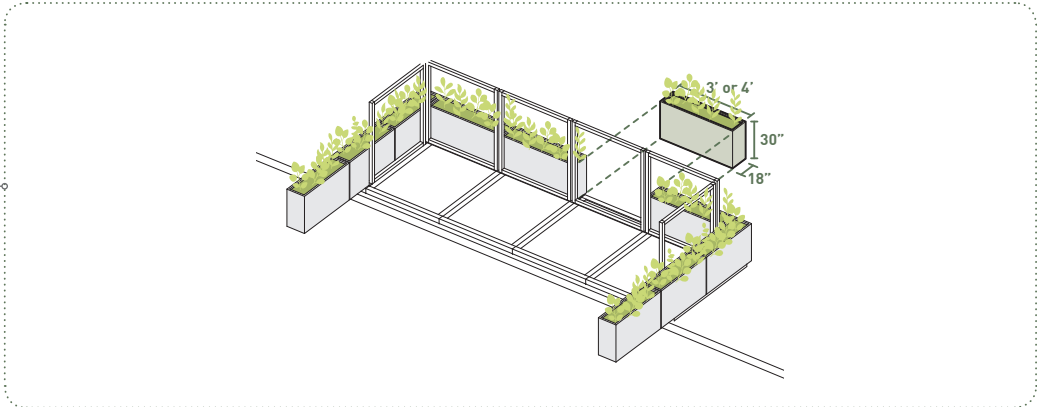

2.3.1.

### Design Standards

#### Overview

Barriers shall be constructed of one of, or a combination of, the following approved materials. Allowable Materials: Concrete; Glass Fiber Reinforced Concrete (GFRC); Steel; Fiberglass

#### Components

- A. Shell
- B. Infill
- C. Landscape (Optional. See Sec. 2.4.)
- D. Screen (Optional. See Sec. 2.5.)

#### Dimensions

18" deep, 36" tall, 3' or 4' wide.

2.3.1.1

( ) Indicate property address on site plan.

2.3.1.2

( ) Provide photo documentation of sidewalk, street, and property.

2.3.1.3

( ) Dimension business frontage.

2.3.2

2.3.2.1

2.3.2.2

### Pre-approved Design

#### Shell

Refer to Appendix XXX for Shop Drawings.

#### Finishes

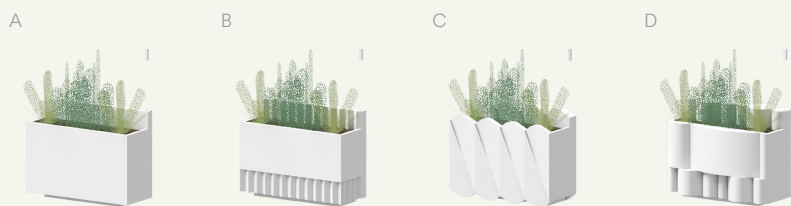

- 1.1
- 1.2
- 1.3
- 2.1
- 2.2
- 2.3
- 2.4
- 2.5
- 2.6
- 2.7
- 2.8
- 2.9
- 2.10
- 3.1
- 3.2
- 3.3
- 3.4
- A

# CONTENTS

The contents of this manual have been divided into three steps. These steps walk through the requirements and approval process that bring a Parklet from idea to fabrication.

## 1

### Step 1: Preparing a Site ..... X

- 1.1 Site Requirements ..... X
- 1.2 Parklet Envelope ..... X
- 1.3 Utility Requirements ..... X

## 2

### Step 2: Designing a Parklet ..... X

- 2.1 Frame ..... X
- 2.2 Flooring ..... X
- 2.3 Barrier ..... X
- 2.4 Furniture ..... X
- 2.5 Landscape ..... X
- 2.6 Screen ..... X
- 2.7 Canopy ..... X
- 2.8 Signage ..... X
- 2.9 Lighting & Sound ..... X
- 2.10 Heating & Cooling ..... X

## 3

### Step 3: Applying for Permit ..... X

- 3.1 Application ..... X
- 3.2 Installation ..... X
- 3.3 Fees ..... X
- 3.4 Removal ..... X

### Appendices ..... X

- A. Forms ..... X
- B. Shop Drawings ..... X
- C. Product Specifications ..... X

**DRAFT**

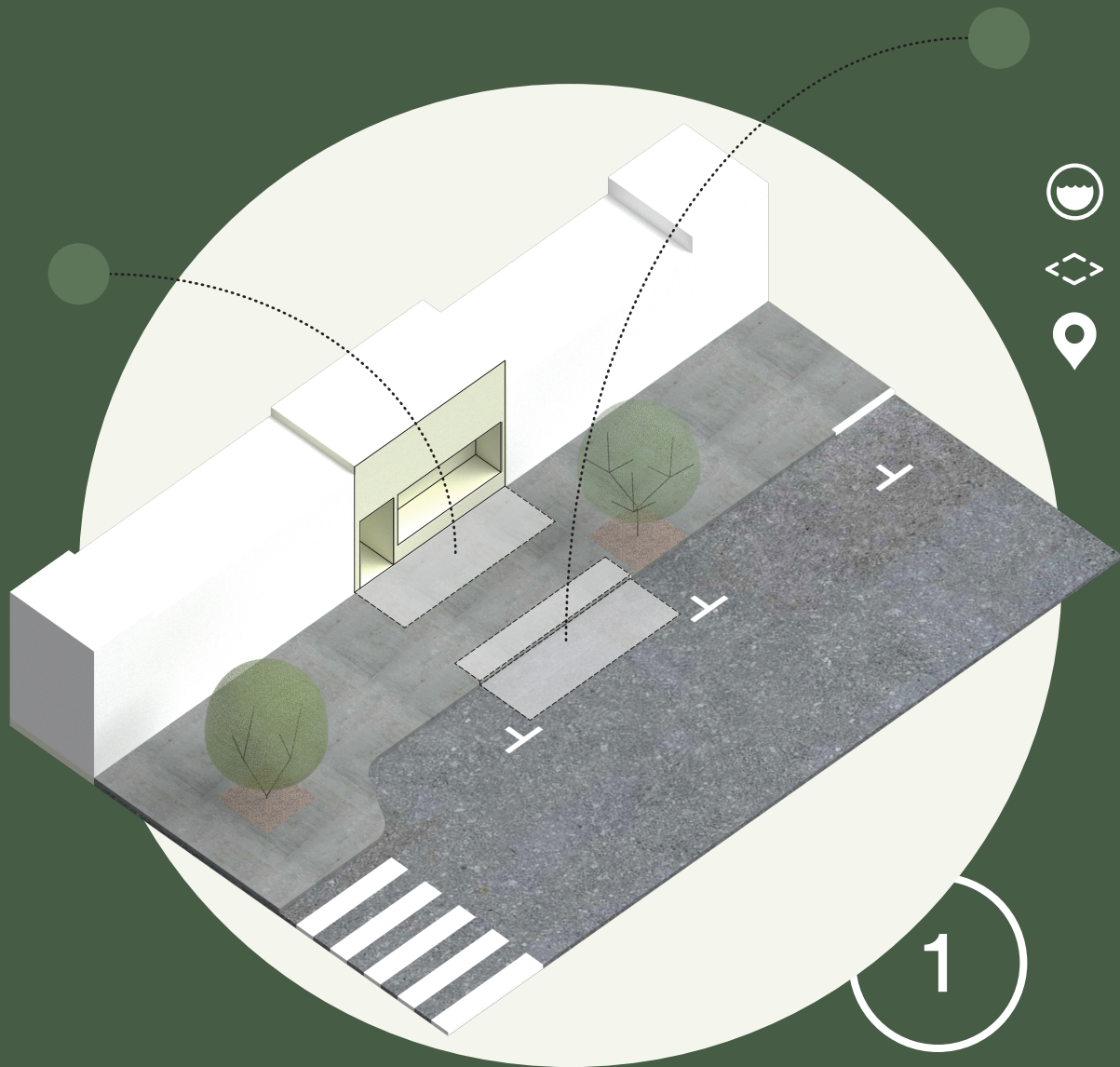

**STEP 1:**

**PREPARING A SITE**

# SITE REQUIREMENTS



This section outlines the restrictions on parklet locations within the City of Beverly Hills. These restrictions have been established to ensure a safe streetscape for pedestrians, vehicles, and diners.

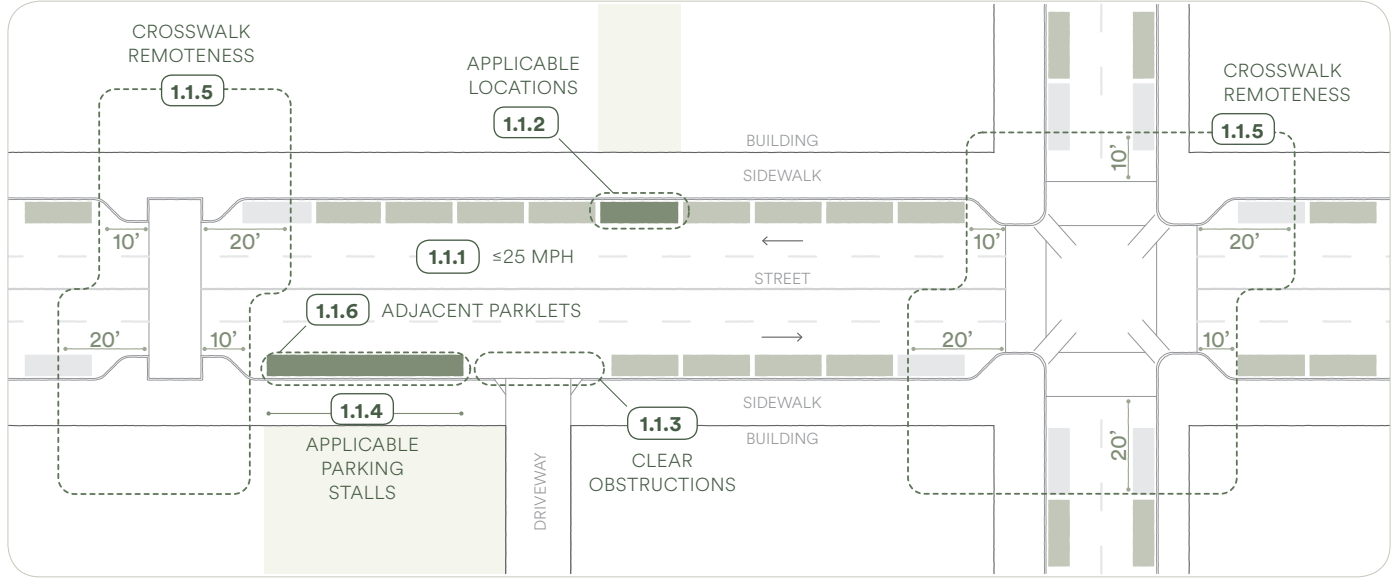

Plan Diagram of Site Requirements

### 1.1.1

( ) Label property address on site plan.

### Applicable Streets

Parklets shall only be located on streets with a speed limit of 25 miles per hour or less.

### 1.1.2

( ) Provide photo documentation of sidewalk, street, and property.

### Applicable Locations

Parklets shall only occupy locations where street parking currently exists and where the extents of each parking stall has been outlined. If there are no painted boundaries, contact the City of Beverly Hills to have the site confirmed applicable for parklets and appropriately marked.

### 1.1.3

( ) Dimension clear distance to all obstructions within 50'-0" of parklet footprint.

### Clear Obstructions

No parklets shall block a driveway, bus stop, alleyway, utility access. Per California Fire Code 507.5.5, a 3-foot clear space shall be maintained around the circumference of hydrants, except as otherwise required or approved. Loading, pick-up, drop-off, or red zones are exceptions subject to review by the City Engineer and Fire Department.

### 1.1.4

( ) Label the parking stalls to be removed for parklet installation.

### Applicable Parking Stalls

Parklets will only be considered at parking locations in front of the business frontage. Additional parking locations may be considered if neighbor consent is provided as described in the Section 1.2.

### 1.1.5

( ) Dimension distance to crosswalks within 50'-0" of parklet footprint and label direction of traffic.

### Crosswalk Clearance

Parklets shall not come within 20'-0" of the outermost crosswalk marking on the approach side of vehicular traffic. Parklets shall not come within 10'-0" of the outermost crosswalk marking on the departure side of vehicular traffic.

### 1.1.6

( ) Label number of continuous parking spaces to remain on either end of parklet.

### Adjacent Parklets

Two adjacent parklets are allowable. Two non-adjacent parklets must have at least 3 continuous parking spaces between them. An exception for fewer than 3 continuous parking spaces is subject to review by the City Engineer.

# PARKLET ENVELOPE



This section outlines the allowable envelope of each parklet. Parklet envelopes have been designed to provide the fair and shared use of the public right of way. The parklet footprint maximizes the potential area for outdoor dining while maintaining both a clear pedestrian right of way and consistent access for emergency response.

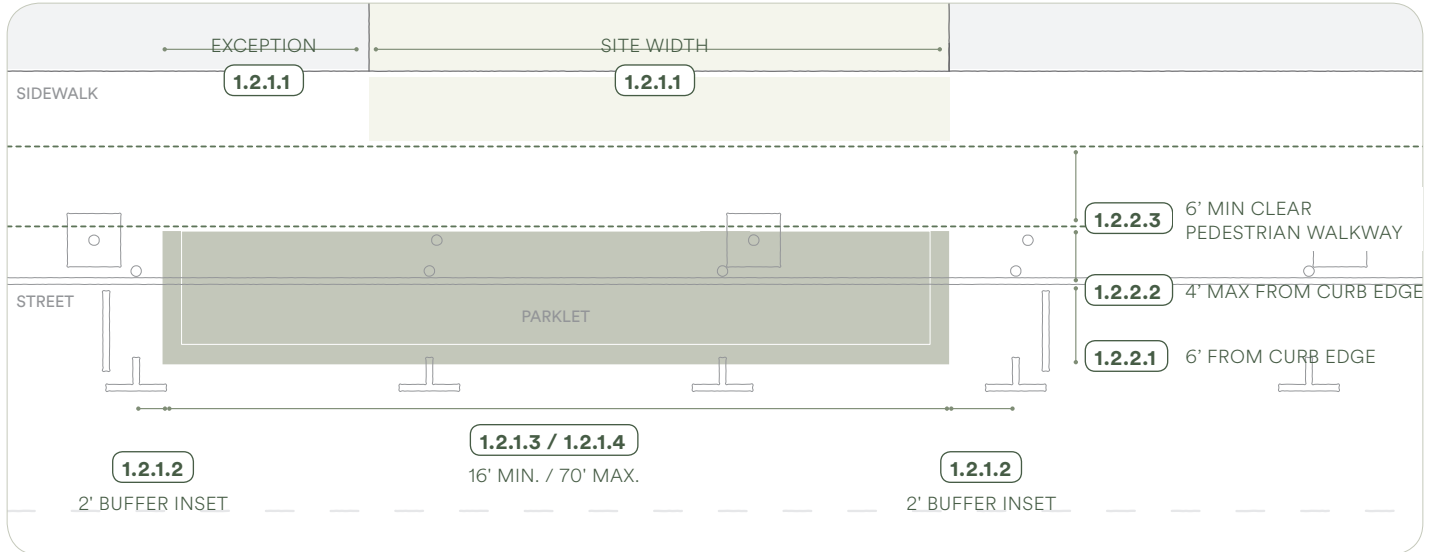

**Plan Diagram of Parklet Envelope, Parallel Parking**

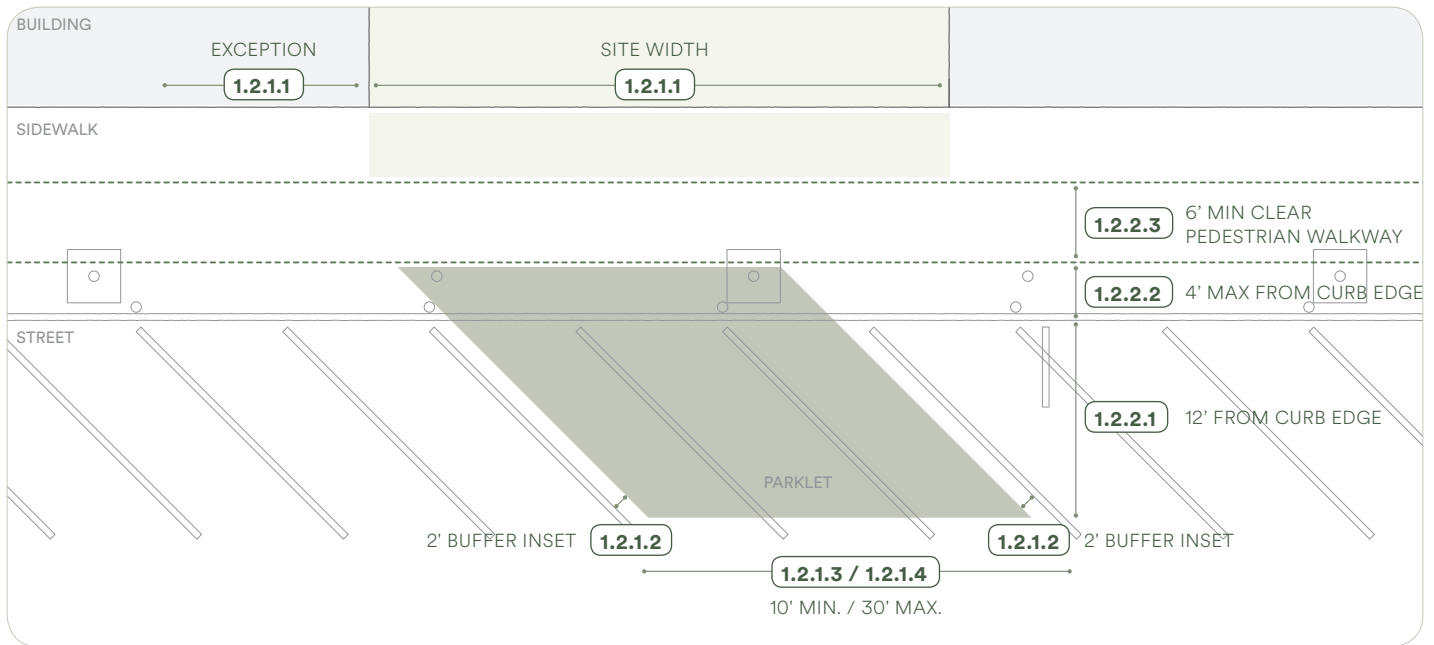

**Plan Diagram of Parklet Envelope, Angled Parking**

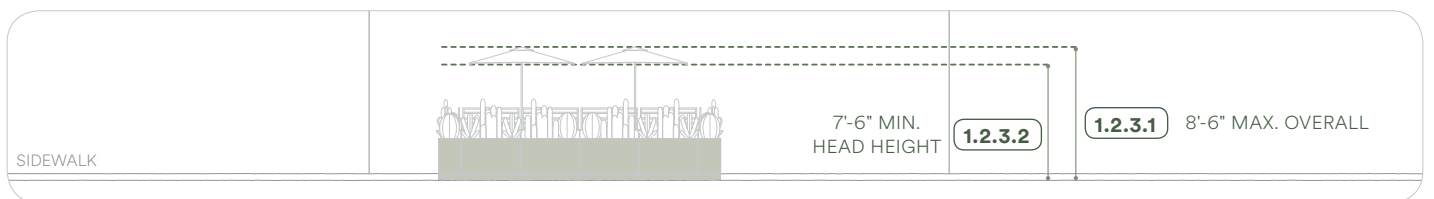

**Elevation Diagram of Parklet Envelope**

# PARKLET ENVELOPE



### 1.2.1

### Width

#### 1.2.1.1

#### Site Width

( ) Dimension business frontage width and site width.

The site width of a parklet shall align to the facade frontage of the associated business. The site width shall not be determined by property lines or existing parking stall locations.

( ) Complete Form ??? if extending parklet into adjacent business frontage.

Exception: The site width of a parklet may be extended in front of an adjacent business facade frontage or frontages with written consent of the business and property owners via form (TBD) in SECTION (TBD). If consent from adjacent business and property owners is withdrawn before or after the parklet has been constructed, the parklet owner shall follow the removal process within the timeframe as outlined in Section 3.4

#### 1.2.1.2

#### Buffer Inset

( ) Dimension inset.

A 2'-0" clear buffer area shall be inset from the overall width at both ends of the parklet.

#### 1.2.1.3

#### Parklet Width Minimum

( ) Dimension parklet width.

An individual parklet shall be no less than 16'-0" wide when replacing parallel parking or 10'-0" wide when replacing angled parking. The minimum width ensures that the weight of the parklet meets the minimum impact requirements described in Section 2.2.

#### 1.2.1.4

#### Parklet Width Maximum

( ) Dimension parklet width.

An individual parklet shall not exceed 70'-0" in width when replacing parallel parking or 30'-0" in width when replacing angled parking. An individual business interested in developing over 70'-0" of parklet space shall divide the site into multiple, adjacent parklets.

### 1.2.2

### Depth

#### 1.2.2.1

#### Street Allowance

( ) Dimension curb face to outermost edge of parklet.

The street facing edge of the parklet shall extend 6'-0" from the face of the curb.

#### 1.2.2.2

#### Sidewalk Allowance

( ) Dimension curb face to innermost edge of parklet.

The sidewalk facing edge of the parklet can extend up to 4'-0" from the face of the curb, provided that the pedestrian clearance is maintained throughout the length of the parklet.

#### 1.2.2.3

#### Pedestrian Clearance

( ) Label and dimension pedestrian path across applicant storefront as well as any storefront immediately adjacent to applicant storefront.

A pedestrian path between the parklet and storefront or parklet and outdoor dining shall be maintained at all times. This path shall be open to sky and shall be a minimum of 6'-0" in width across its entire length. The path shall connect to existing pedestrian clear walkways at either end of the storefront and ensure a minimum 6'-0" clear path is maintained throughout.

### 1.2.3

### Height

#### 1.2.3.1

#### Overall Height

( ) Dimension parklet overall height.

No part of the parklet, furniture, or canopy shall extend more than 8'-6" above the level of the adjacent sidewalk.

#### 1.2.3.2

#### Head Height

( ) Dimension clear head height below any overhead obstructions.

A clear 7'-6" head height clearance shall be maintained throughout the entire parklet footprint. The parklet shall not be sited in any way that lowers the adjacent head height clearance of the sidewalk or street.

# UTILITY REQUIREMENTS



This section refers to the addition, modification, and delineation of streetscape utilities associated with each parklet. Appropriate care for streetscape utilities ensures that each parklet does not create any negative impact to the safety and/or operations of the public right of way.

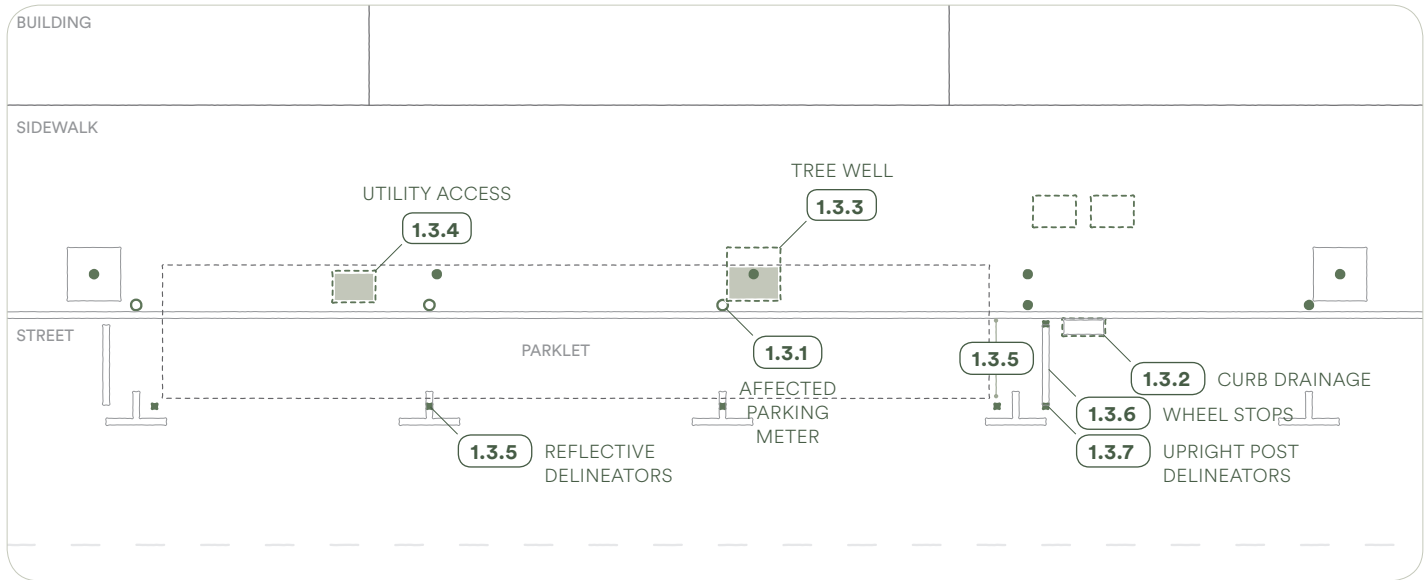

**Plan Diagram of Utility Requirements**

### 1.3.1

( ) Label meters to be removed.

### Affected Parking Meters

Meters that are assigned to decommissioned parking spaces (as a result of parklet installation or associated streetscape safety) shall be removed. Meter removal will be provided by the City of Beverly Hills.

### 1.3.2

( ) Label storm drain nearest to parklet.

### Storm Drainage

Parklets shall be installed as to not block drainage to storm drains from sidewalk, street or existing curb drains.

### 1.3.3

( ) Label parklet footprint overlap with any tree wells.

### Tree Well

Parklets shall be installed as to not block drainage through tree wells.

### 1.3.4

( ) Label parklet footprint overlap with all utility access.

### Utility Access

Parklets installed above utility access points shall be clearly marked. A 2" white outline shall be painted on the parklet flooring to label the outline of the utility access point.

### 1.3.5

( ) Label and dimension reflective delineators.

### Reflective Delineators

3" x 9" silver, reflective, rectangular delineators shall be mounted to the outermost surface of the parklet on the vehicular side. Reflective delineators shall be placed at each corner and along each outside face with no more than 10'-0" between two sequential delineators.

### 1.3.6

( ) Label and dimension wheel stops.

### Wheel Stops

A 6'-0" concrete wheel stop shall be mounted 4'-0" from the ends of any parklet adjacent to a parking stall, drop off zone, or loading area. The wheel stop will be installed by the City of Beverly Hills.

### 1.3.7

( ) Label posts.

### Upright Post Delineators

A 3'-0" delineator shall be mounted at the ends of each wheel stop. The delineator will be installed by the City of Beverly Hills.

DRAFT

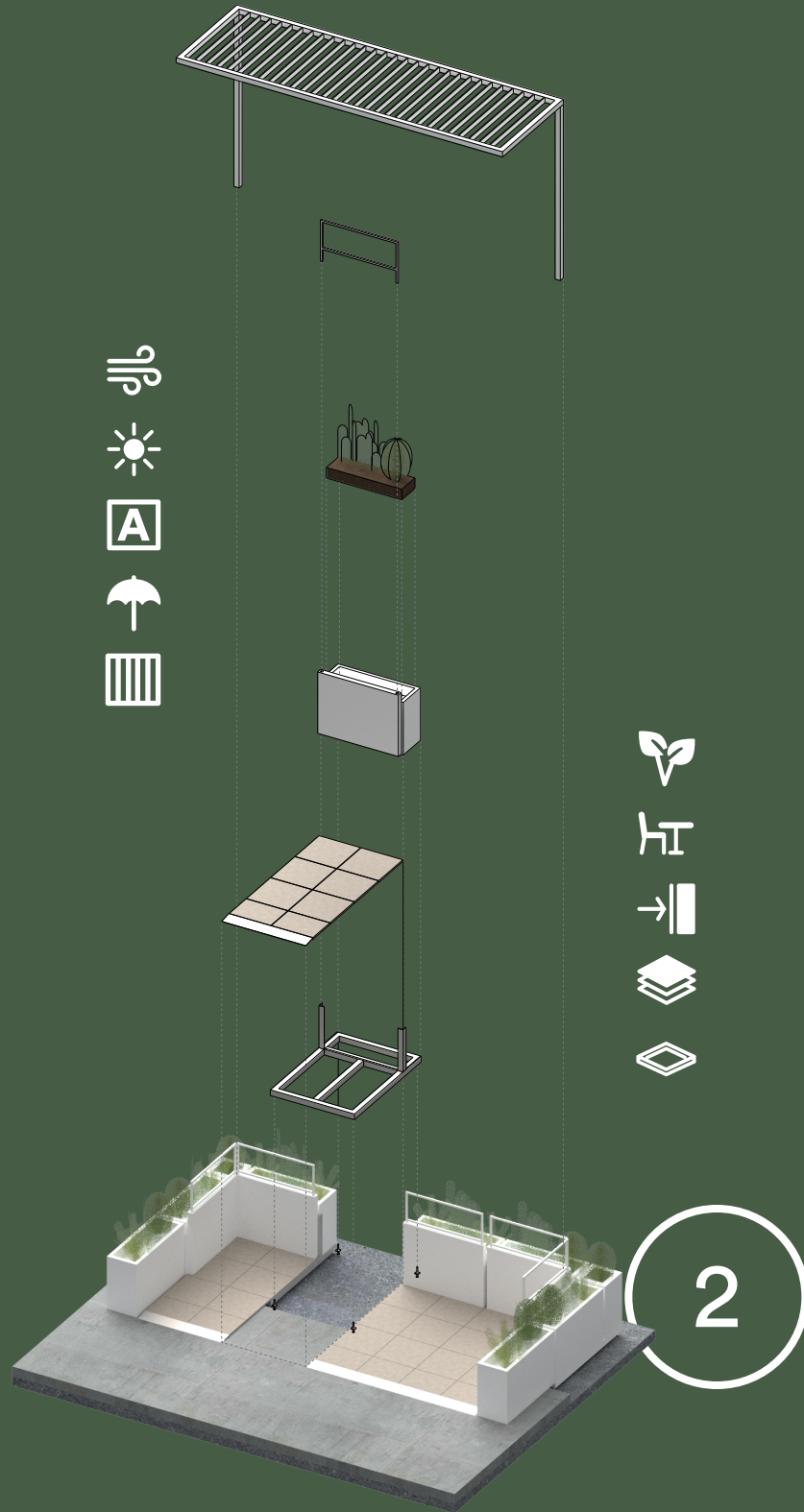

STEP 2:

DESIGNING A PARKLET

# FRAME



**ESSENTIAL FOR OPERATION.** The frame provides a durable, level base on which to build the parklet. The frame allows all parklet elements to be anchored together without being fixed to the street, curb, or sidewalk.

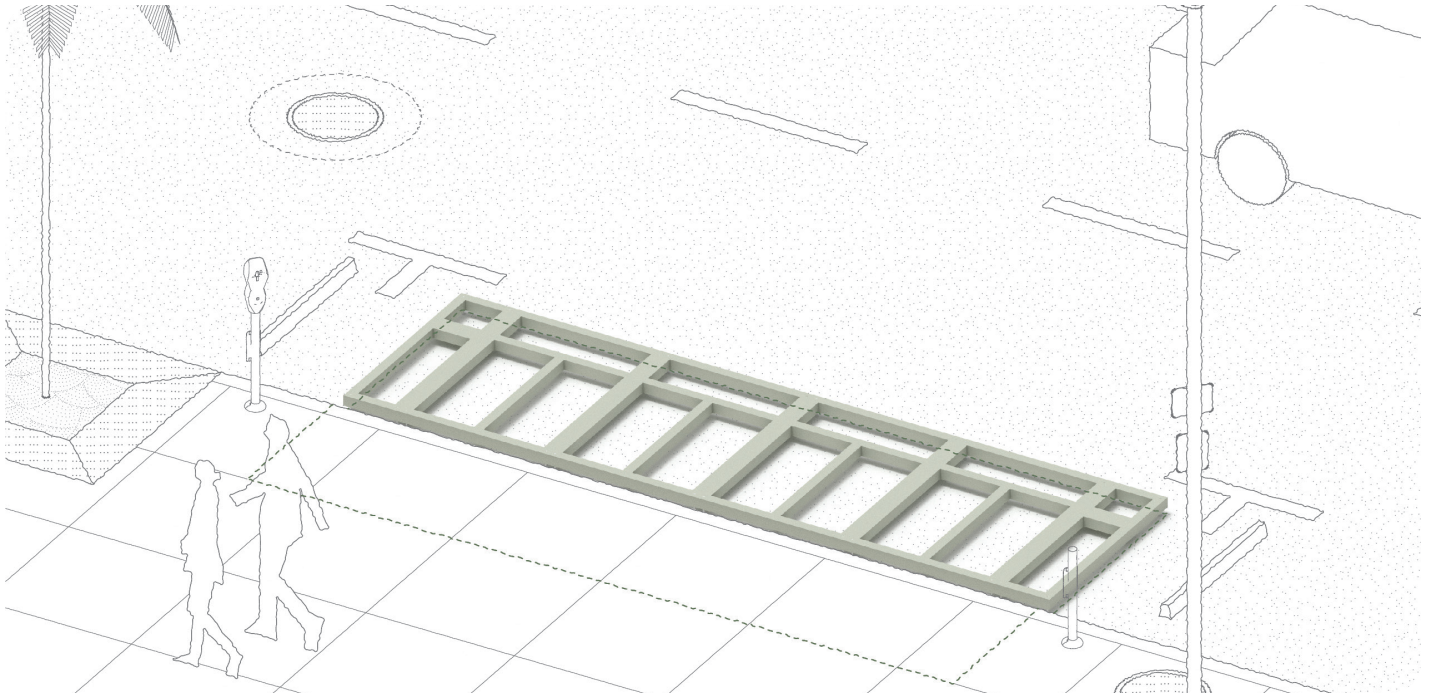

### 2.1.1

( ) Provide material specifications & connection details.

( ) Provide structural drawings stamped by Structural Engineer.

### 2.1.2

( ) Provide structural drawings stamped by Structural Engineer.

### 2.1.3

( ) Label all slope and elevation changes.

### 2.1.4

( ) Provide detail with dimensions.

### Material

The frame shall be constructed of one of, or a combination of, the following approved materials.. The frame finish shall minimize potential corrosion. The frame or raised deck must be capable of resisting live load of 100 psf.

Allowable Materials: Powder-coated or painted steel; Aluminum

Materials not recommended: Wood (due to deterioration and maintenance issues); Concrete; and any materials not listed as allowable

### Pedestals

The frame shall be set onto pedestals that have been engineered to capture a minimum of 100 lbs per sf of liveload. Pedestals shall designed as to not negatively impact drainage to storm drains from sidewalk or street. No part of the parklet frame or pedestals shall be fixed to the street, curb, or sidewalk.

### Leveling

The top surface of the frame shall be set level to the elevation of the adjacent curb. The slope of the frame in any direction shall not exceed 1/48 (or 2%).

### Curb Clearance

The frame shall be designed to provide a minimum 6" wide by 4" high clear channel at the curb edge.

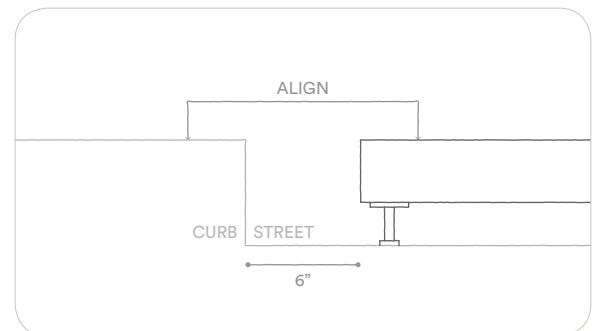

### 2.1.K

### Kit-Of-Parts (see next page)

# FRAME



### 2.1.K

( ) TBD

#### Kit-of-Parts

The kit of parts frame has been designed and engineered to meet all of the above criteria. A modular system allows the frame to meet any required parklet length.

#### Dining Modules

Powder coated steel dining modules are available in either 3'-0" or 4'-0" lengths. Each module can be bolted together on site. They have been designed to directly accept the vehicular barrier, flooring, and optional canopy. Adjustable steel pedestals provide easy on-site leveling.

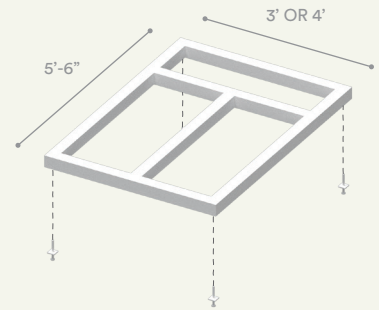

SEE APPENDIX (TBD) FOR SHOP DRAWINGS.

#### End Modules

Powder coated steel end modules are 1'-6" x 6'-0" and have been designed to support the barriers at either end of the parklet. Adjustable steel pedestals provide easy on-site leveling.

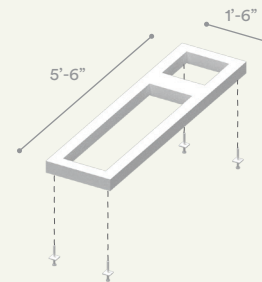

SEE APPENDIX (TBD) FOR SHOP DRAWINGS.

Note: The Kit of parts have been prepared with shopdrawings and calculations that are pre-approved and will be available to business shall they choose to use this system, material procurements and installations will be the responsibility of the businesses.

# FLOORING



ESSENTIAL FOR OPERATION. Parklet flooring shall be designed to cover the frame and sidewalk and shall label a distinct dining area separate from the pedestrian right of way. The flooring shall be aesthetically tied to the associated business to demonstrate a relationship between the parklet and business.

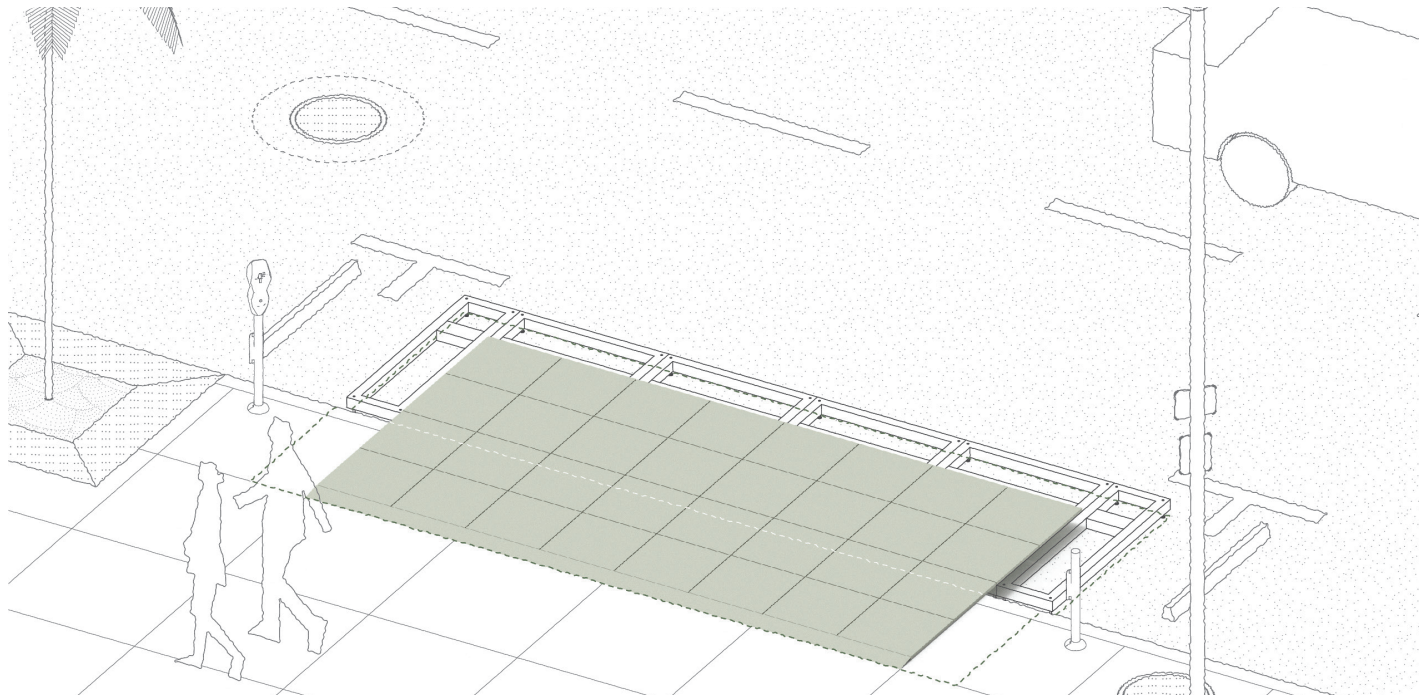

### 2.2.1

( ) Provide material specifications & connection details.

( ) Provide structural drawings stamped by Structural Engineer.

### Material

Parklet flooring shall be constructed of one of, or a combination of, the following approved materials.

Allowable Materials: Porcelain Pavers, Concrete Pavers, PVC Deck (Fire-Retardant Treated), Pressure-Treated Wood (Fire-Retardant Treated)

Prohibited Materials: Untreated Wood; Plywood; Carpeting; Artificial Turf; Any materials not listed as allowable

Breaking Strength: >2,250 lbf

Finishing & Slip Resistance: Minimum 0.6 Coefficient of Friction

### 2.2.2

( ) Provide detail with dimensions.

### Installation

Flooring shall be installed as to not provide gaps larger than 1/4". Flooring shall not be fixed or adhered to street, curb, or sidewalk.

### 2.2.3

( ) Provide detail with dimensions.

### Cleaning Access

To provide access to the street for regular cleaning, flooring shall be installed in removable panels not to exceed a footprint of 4'-0" x 8'-0".

### 2.2.4

( ) Provide detail with dimensions.

### Threshold

An ADA approved threshold shall be attached to the sidewalk edge of the flooring such that the transition between sidewalk and parklet does not exceed either a 1/12 slope nor a 3" rise.

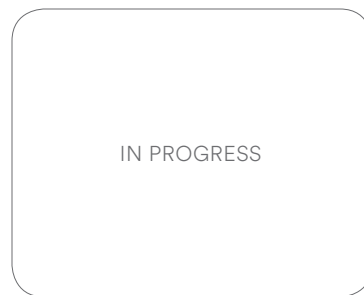

**ADA Thresold Diagram**

### 2.2.K

### Kit-Of-Parts (see next page)

# FLOORING



### 2.2.K

( ) (TBD)

#### Kit-of-Parts

The kit of parts flooring has been selected to meet all of the above criteria. Standard tile sizes of 1'x2', 2'x2', and 2'x4' can each be used with the kit of parts frame. Standard planking with a 6" or 12" width can be used with the kit of parts frame.

#### Flooring Materials

Porcelain Paver



Concrete Paver

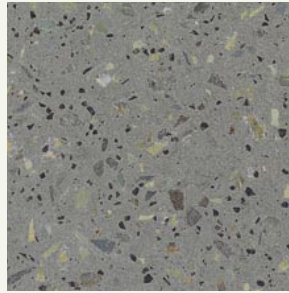

Engineered Decking



SEE APPENDIX (TBD) FOR ADDITIONAL OPTIONS AND PRODUCT SPECIFICATIONS.

# BARRIER



**ESSENTIAL FOR OPERATION.** Barriers provide separation of dining and vehicular traffic. Using a weight based system, diner safety is significantly improved without the need for permanent attachment to the street or sidewalk.

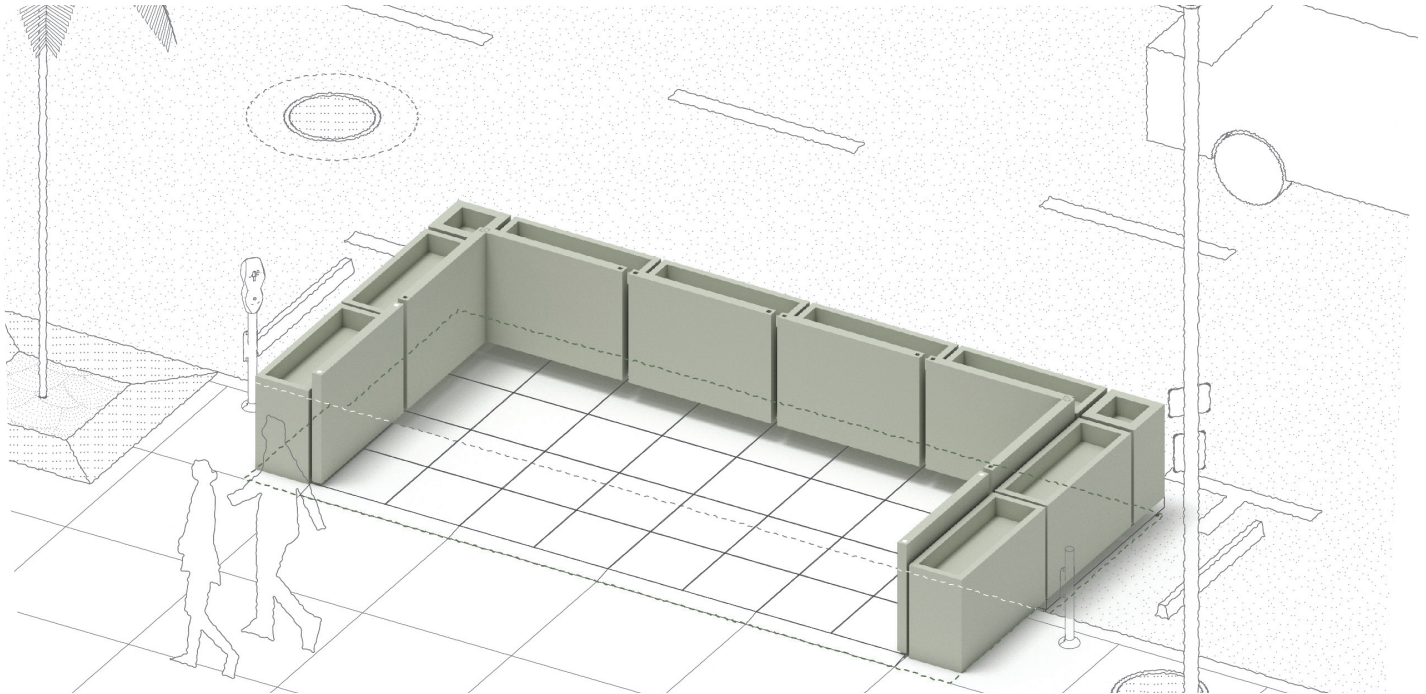

### 2.3.1

( ) Provide material specifications & connection details.

( ) Provide structural drawings stamped by Structural Engineer.

### 2.3.2

### 2.3.3

( ) Provide detail with dimensions.

( ) Provide structural drawings stamped by Structural Engineer.

### 2.3.4

( ) Provide detail with dimensions.

( ) Provide structural drawings stamped by Structural Engineer.

### 2.3.5

( ) Provide structural calculations stamped by Structural Engineer.

### Material

Barriers shall be constructed of one of, or a combination of, the following approved materials.

Allowable Materials: Concrete; Glass Fiber Reinforced Concrete (GFRC); Steel; Fiberglass  
Prohibited Materials: Wood, Plywood, Plastic, Ceramic, Terracotta, Foam

### Finish

TBD

### Vehicular Side Requirements

Barriers shall extend 30" above the frame on the vehicular traffic side to meet the required impact height. Barriers shall be engineered to resist a force of 6,000 lbs when applied at 30" above the level of the street. Barriers shall not create any openings such that a 4" diameter sphere could pass through to the opposite side.

### Pedestrian Side Requirements

Barriers shall extend 38" above the frame on the pedestrian side to meet the required fall protection height. Barriers shall be engineered to resist a force of 200 lbs point load when applied at 36" above the level of the parklet flooring. Barriers shall not create any openings such that a 4" diameter sphere could pass through to the opposite side.

### Weight

Barriers shall weigh a minimum of (TBD) lbs in total.

## 2.3

# BARRIER



### 2.3.6

( ) Provide detail with dimensions.

#### Depth

Barriers shall be a minimum of 12" deep. Barriers shall not extend more than 3" into the buffer zone area on any side of the parklet.

### 2.3.7

( ) Provide detail with dimensions.

#### Attachment

Barriers shall be set on top of the frame, but do not need to be secured to the frame. Barriers shall be secured to one another to create a singular, continuous weight for impact resistance.

### 2.3.K

( ) (TBD)

#### Kit of Parts

Custom barriers have been designed and engineered to meet all of the criteria above. The custom barriers fit directly into the kit of parts frame. Additionally, these barriers are ready-made to accept vegetation, safety delineators, privacy screens, and quick installation via forklift.

#### Construction & Assembly

Refer to Appendix (TBD) for shop drawings.

#### Modular Design

Available in 3'-0" x 18" or 4'-0" x 18"

Standard Modern



Fluted

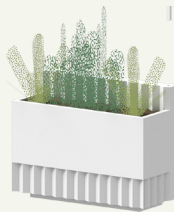

Pleated



Scalloped



SEE APPENDIX (TBD) FOR SHOP DRAWINGS.

#### Corner Design

Available in 18" x 18" or 18" angled

#### Finishes

TBD

Note: The Kit of parts have been prepared with shopdrawings and calculations that are pre-approved and will be available to business shall they choose to use this system, material procurements and installations will be the responsibility of the businesses.

# FURNITURE



ESSENTIAL FOR OPERATION. Parklet furniture shall activate parklets in use. The furniture guidelines have been designed to ensure diner comfort while maintaining pedestrian accessibility.

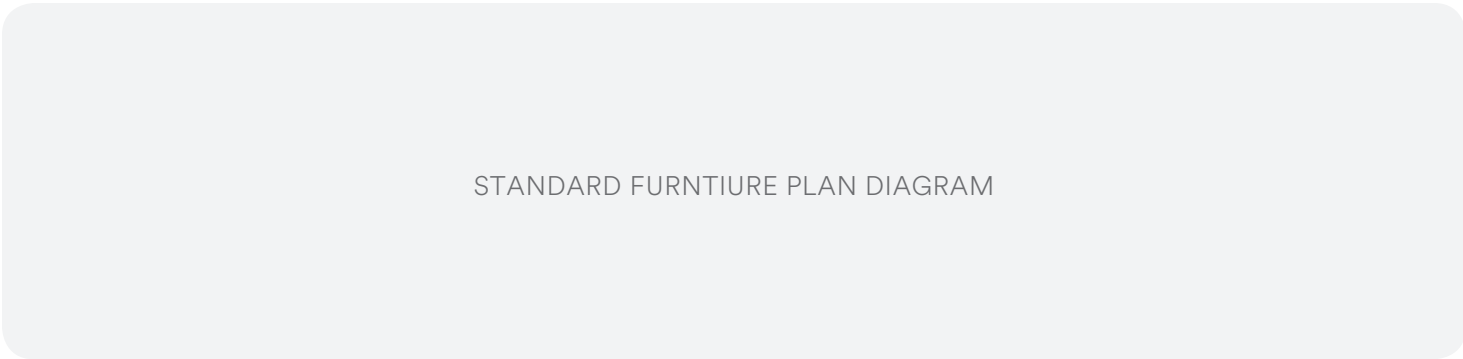

STANDARD FURNITURE PLAN DIAGRAM

### 2.4.1

( ) Provide a dimensioned furniture plan indicating the overall seat count and location of ADA wheelchair accessible seats. Provide a key plan of each seating arrangement, label, dimension and provide product specifications.

### Furniture Planning

No furniture, whether in-use or not-in-use, shall be outside of the parklet boundary. It is recommended that seating shall be oriented such that no chair has its back to the pedestrian clear walkway. No tables, chairs or decorative items shall obstruct and fire protection equipment (ie; FDC, Fire Sprinkler Riser or Knox Box. FDC shall have complete pathway clearance from the street.

Furniture plans shall include a dimensioned key plan of all types of seating and surfaces to be used. Seating shall be organized to provide a minimum 32" clear access aisle to each seating arrangement.

A minimum of (TBD) % of dining seating shall be designed to accommodate ADA wheelchair access. Wheelchair access shall allow for a 30" x 48" clear resting space at the table or countertop. Access to all ADA wheelchair accessible seating shall be through an aisle with a minimum width of 36".

A total seat count shall be indicated on the plans. Fixed seating, like benches, shall be counted as 1 seat for every linear 30".

### 2.4.2

( ) Provide product specifications.

### Furniture Material

Furnishings selected for parklets shall be designed for outdoor use, regardless of whether a canopy is provided. Furniture specifications indicating approval of outdoor use shall be provided in the application.

### 2.4.3

( ) Provide detail with dimensions.

### Fixed Furniture

Fixed furniture shall be constructed with (TBD) materials. Fixed seating shall provide a minimum 18" depth. No fixed furniture shall be more than 48" high when measured from the surface of the parklet.

### 2.4.4

### Not-In-Use Storage

Furniture not-in-use shall remain within the parklet footprint or within the business. No furniture shall be stored on the street, sidewalk, or near adjacent properties.

### 2.4.5

### Clearances

Required exits, pathways or exit discharges shall be continuously maintained free from obstructions or impediments to full instant use in the case of fire or other emergency when the areas served by such exits are occupied. Security devices affecting means of egress shall be subject to the approval of the fire code official. Aisles shall be maintained and kept free from obstructions. Posted occupancy shall not be exceeded unless approved by fire department.

# LANDSCAPE



NOT ESSENTIAL FOR OPERATION, however, all landscape shall comply with the section below. Plant selection shall follow the guidelines as outlined in this section. The pre-designed landscape palettes can be used as part of the kit of parts approach, or in combination with custom designs.

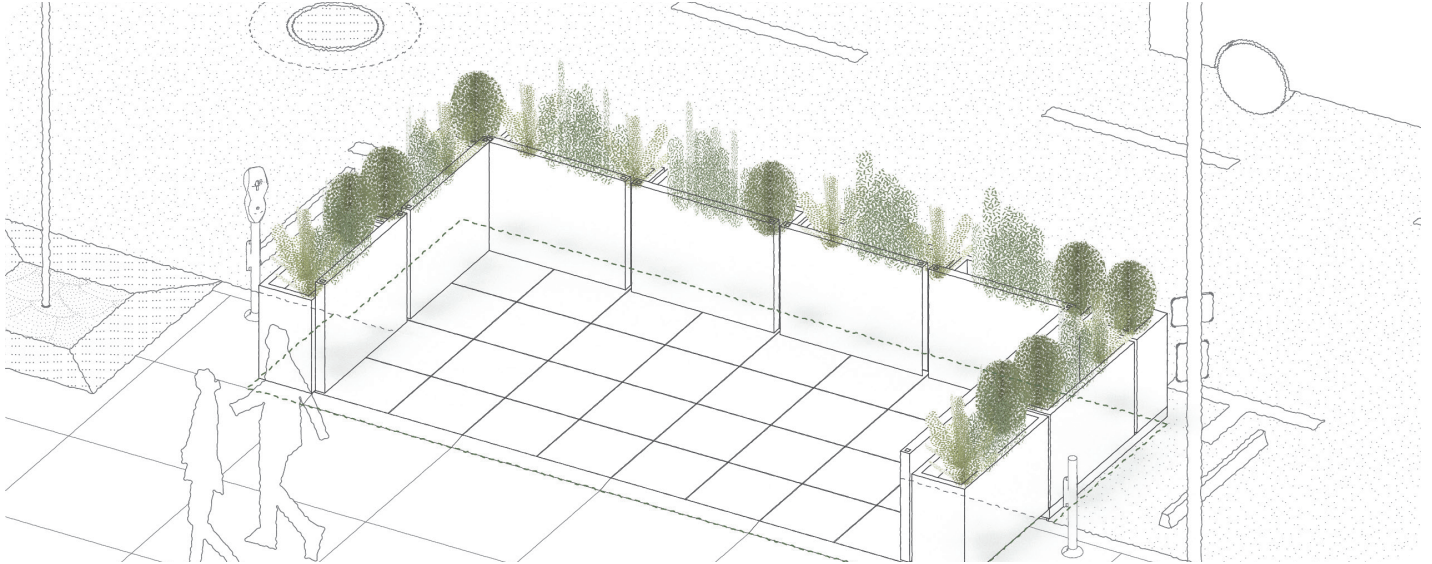

### 2.5.1

( ) Provide material specifications. Indicate maximum growth potential of selected materials.

### Plant Selection

Plant selection outside of the kit-of-parts palettes will be subject to discretionary review to ensure a level of transparency as deemed appropriate by the City. Planting and soil shall be organic material. Non-organic and imitation planting is not standard and will require an independent approval with the Fire Department.

Allowable Materials: Plant species native to Southern California

Prohibited Materials: Box hedges; Bamboo; Evergreen shrubs or similar plantings that create a hedge effect as described below

### 2.5.2

( ) Provide detail with dimensions.

### Soil Depth

Planters shall provide a minimum of 9" for soil and gravel drainage to ensure plant health.

### 2.5.3

( ) Provide planting plan and elevation.

### Height

At full growth, no singular plant shall exceed a height of more than 24" above the planter.

### 2.5.4

( ) Provide planting plan and elevation.

### Spread

At full growth, no singular plant shall exceed a footprint of 18" in any direction. Planting shall not extend more than 6" into the buffer zone on any side of the parklet.

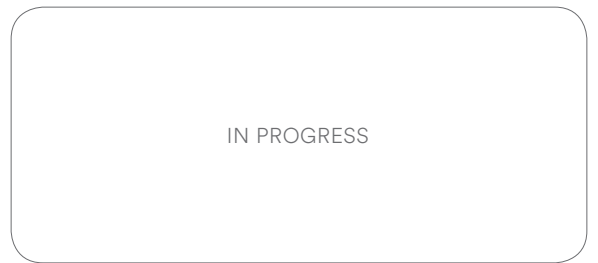

Soil depth, max. spread and height diagram

### 2.5.5

( ) Provide planting plan and elevation.

### Hedge Effect

Plant selection shall be varied as to avoid a hedge effect. A hedge effect is any plant or series of plants that eliminates clear visibility between either side of the planter.

### 2.5.6

( ) Provide plant maintenance schedule.

### Growth Maintenance

Plant growth shall be maintained as to not exceed the spread and height described above.

### 2.4.7

### Kit-Of-Parts (see next page)

# LANDSCAPE



### 2.5.K

( ) (TBD)

#### Kit of Parts

Pre-designed planting palettes have been selected to meet all of the criteria above. Plant selection, planting plans, soil substrates, and maintenance guidelines have been provided for each palette.

#### Installation

Refer to Appendix (TBD) for shop drawings.

#### Palettes

Available in 3'-0" x 18", 4'-0" x 18", or 18" x 18" planting plans.

Morning Coffee

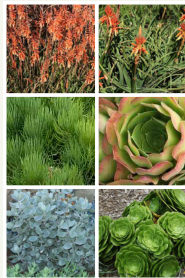

Bright Brunch



Out To Lunch

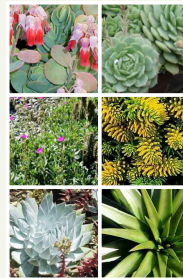

Dinner Date

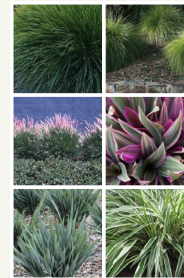

Dessert Menu

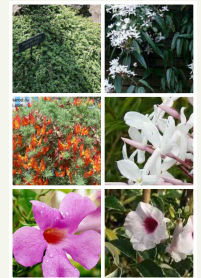

SEE APPENDIX (TBD) FOR DRAWINGS AND SPECIFICATIONS.

# SCREEN



NOT ESSENTIAL FOR OPERATION, however, all screening shall comply with the section below. The screen guidelines have been designed to add to diner comfort while maintaining driver and pedestrian visibility across the street.

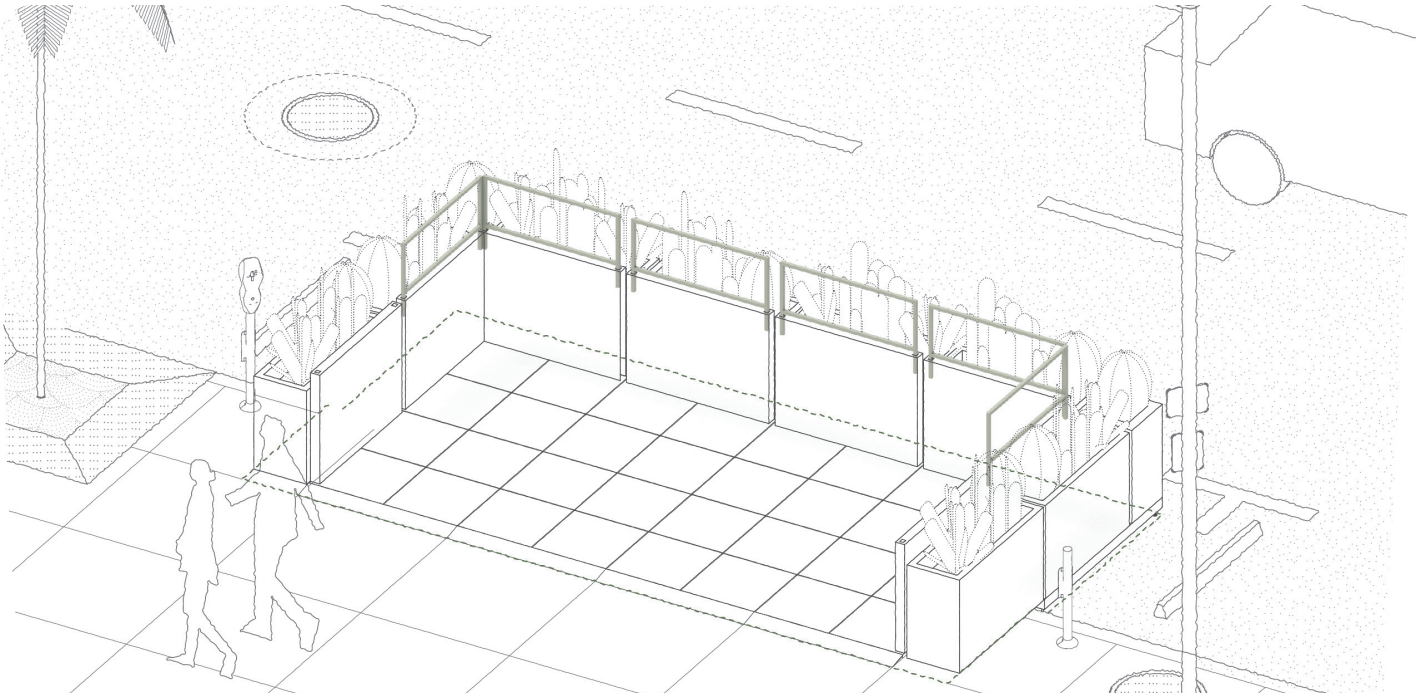

1.1

1.2

1.3

2.1

2.2

2.3

2.4

2.5

2.6

2.7

2.8

2.9

2.10

3.1

3.2

3.3

3.4

A

### 2.6.1

( ) Provide material specifications & connection details.

### Materials

The frame shall be constructed of one of, or a combination of, the following approved materials. The screen finish shall minimize potential corrosion.

Allowable Materials: Powder-coated or painted steel; Aluminum; Pressure-treated wood (Fire-Retardant Treated); Approved glazing as described below

Prohibited Materials: Fabric, Artificial turf

### 2.6.2

( ) Provide material specifications & connection details.

### Glazing

Screens are permitted to use glazing provided that it is designed for impact safety. Glass is approved. Alternate transparent materials like acrylic, PVC, or polycarbonate may be allowed on by discretion of the City.

### 2.6.3

( ) Dimension.

### Screen Location

Screens shall be installed at least 12" inside the outermost edge of the parklet barrier.

### 2.6.4

( ) Dimension.

### Screen Height

Screens shall have a maximum height of no more than 54" above the parklet flooring.

### 2.6.5

( ) Provide opacity calculation.

### Opacity

Screens shall have an unobstructed visibility of at least 70% of the total exterior elevation. Visibility can be achieved through either openings or transparent glazing. Any part of glazing with tint, frit, or decal that shall not be counted towards the percent visibility.

IN PROGRESS

Opacity calculation diagram

### 2.6.K

### Kit-Of-Parts (see next page)

# SCREEN



### 2.6.K

( ) (TBD)

#### Kit of Parts

The kit of parts screens have been designed and engineered to meet all of the criteria above. These screens can slot directly into the kit of parts barriers without any additional support.

#### Installation

Refer to Appendix (TBD) for shop drawings.

#### Modular Design

Available as 3'-0" wide x 18" tall or 4'-0" wide x 18" tall screens.

Horizontal Bar

Vertical Bar

Diagonal Slat

Safety Glass

Horizontal Bar



Vertical Bar

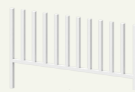

Diagonal Slat

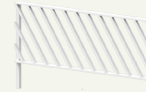

Safety Glass



SEE APPENDIX (TBD) FOR SHOP DRAWINGS.

Note: The Kit of parts have been prepared with shopdrawings and calculations that are pre-approved and will be available to business shall they choose to use this system, material procurements and installations will be the responsibility of the businesses.

# CANOPY



NOT ESSENTIAL FOR OPERATION, however, all canopies shall comply with the section below. The canopy guidelines have been designed to provide solar and rain screening while maintaining a safe head height for user comfort and visibility.

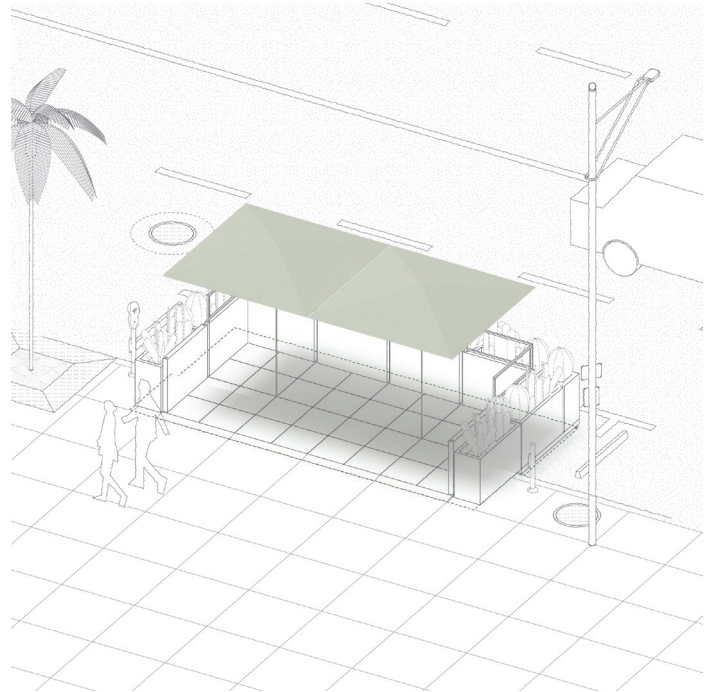
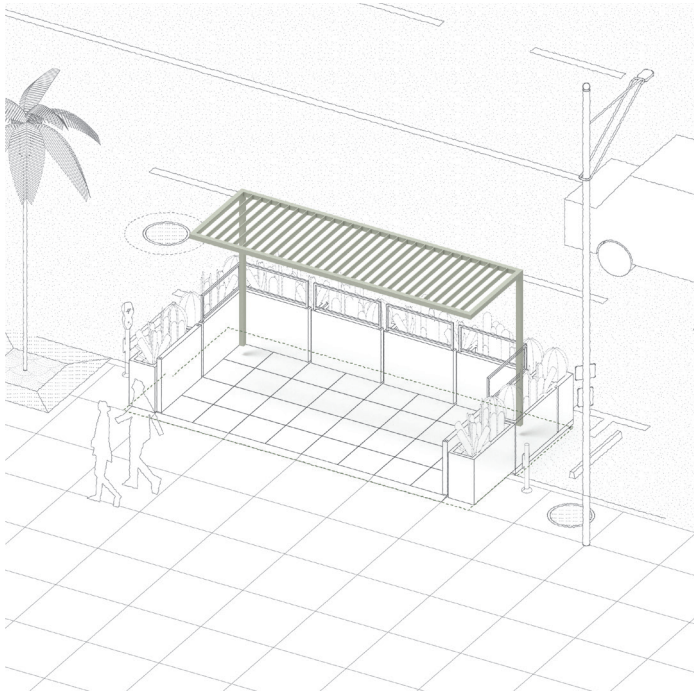

### 2.7.1

### General Canopy Requirements

#### 2.7.1.1

( ) Provide material specifications & connection details.

#### Materials

The canopy shall be constructed of one of, or a combination of, the following approved materials. The canopy finish shall minimize potential corrosion. Materials shall not be ripped, torn, falling down, stained, and must be regularly cleaned by Parklet Owner. Materials shall be CSFM listed or composed of materials meeting the flame propagation performance of Test 2 of NFPA 701 per CFC 3101.2. Overhead structures should be designed by a CA licensed professional for both gravity and lateral loads (Seismic or wind whichever governs).

Allowable Materials: Exterior grade canvas; Polyester; Polyethylene; Vinyl

Prohibited Materials: Flammable materials; Artificial turf

#### 2.7.1.2

( ) Dimension heights on all elevations.

#### Height

Canopies shall provide a minimum 7'-6" head height clearance. Canopies shall not exceed a maximum 8'-6" overall height

#### 2.7.1.3

( ) Dimension footprint on plans.

#### Footprint

Canopy footprint shall be contained entirely within parklet footprint. No canopy, either mobile or fixed, shall be installed to come within 1'-0" of the outermost perimeter of the parklet.

#### 2.7.1.4

( ) Provide material specifications & connection details.

#### Installation

Canopies shall not be bolted or affixed to the street, curb, or sidewalk. Pedestals shall be provided such that the weight, spread, and/or attachment to the parklet frame deters overturning. Mobile canopies shall be mechanically fastened to their bases.

#### 2.7.1.5

#### Not-In-Use Storage

TBD



### 2.7.2

#### Fixed Canopy Requirements

In addition to the general canopy requirements above, fixed canopies should also meet the standards below.

#### 2.7.2.1

( ) Provide material specifications & connection details.

#### Materials

The canopy should be constructed of one of, or a combination of, the following approved materials. The canopy finish should minimize potential corrosion. Materials shall not be ripped, torn, falling down, stained, and must be regularly cleaned by Parklet Owner. Materials shall be CSFM listed or composed of materials meeting the flame propagation performance of Test 2 of NFPA 701 per CFC 3101.2.

Allowable Structural Frame Materials: Powder-coated or painted steel; Aluminum; Pressure-treated wood (Fire-Retardant Treated)

#### 2.7.2.2

( ) Provide material specifications & connection details.

#### Installation

The canopy should be fixed to the parklet frame. The canopy should be engineered to provide a minimum strength of ??? lbs per sf.

### 2.7.K

( ) TBD

#### Kit of Parts - Mobile Canopy

The kit of parts canopies have been selected to meet all of the criteria above.

#### Canopy Types

6' Diam Round Footprint



7' Square Footprint



7' Side Square Footprint



SEE APPENDIX (TBD) FOR SHOP DRAWINGS.

### 2.7.K

( ) TBD

#### Kit of Parts - Fixed Canopy

The kit of parts canopies have been designed and engineered to meet all of the criteria above. These canopies can be attached directly to the kit of parts base frame.

#### Canopy Types

Retractable Canvas Canopy

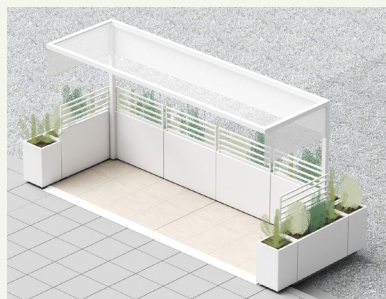

Adjustable Wood Louver Canopy

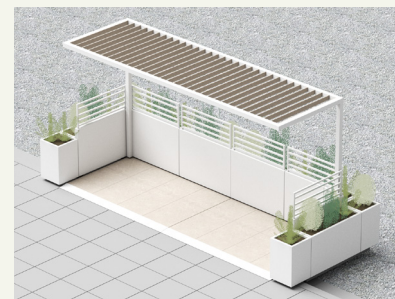

SEE APPENDIX (TBD) FOR SHOP DRAWINGS.

Note: The Kit of parts have been prepared with shopdrawings and calculations that are pre-approved and will be available to business should they choose to use this system, material procurements and installations will be the responsibility of the businesses.

# SIGNAGE

NOT ESSENTIAL FOR OPERATION, however, all signage shall comply with the section below. The signage guidelines have been designed to compliment the storefront signage requirements in Beverly Hills.

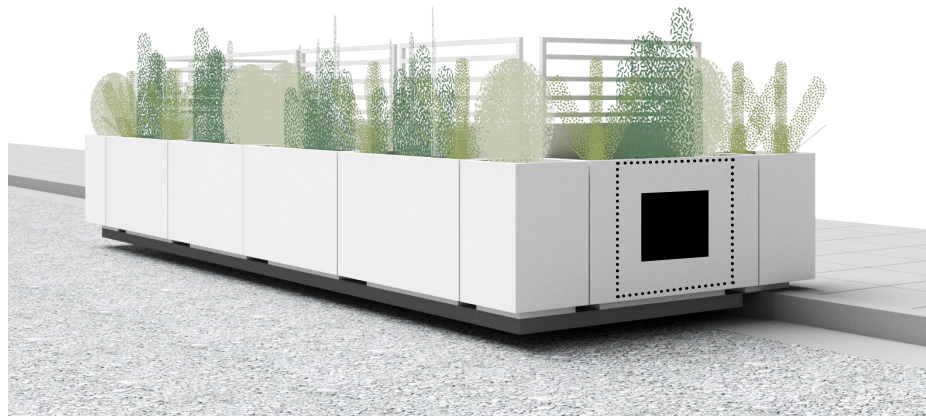

### 2.8.1

( ) Provide material specifications & connection details.

#### Allowable Materials

The frame shall be constructed of one, or a combination, of the following approved materials. The screen finish shall be weather-resistant to minimize potential corrosion.

Allowable Materials: Aluminum; Stainless steel; Acrylic; Vinyl  
Prohibited Materials: Lighting or Illumination, Wood, Glass

### 2.8.2

#### Business Signage

#### 2.8.2.1

( ) Dimension brands on all elevations.

#### Size

One brand or logo permissible on each exterior face of the parklet. Each brand or logo shall cover less than 2 SF. Refer to the city code and signage guidelines.

#### 2.8.2.2

( ) Indicate allowable placement area.

#### Placement

Brand or logo shall be in the center third of the face of the parklet.

#### 2.8.2.2

( ) Provide material specifications & connection details.

#### Depth

Brand or logo shall protrude less than 1" from the surface of the parklet.

#### 2.8.2.3

#### Content

Signs shall only contain the name and/or logo of the business.

### 2.8.3

#### Other Signage

#### 2.8.3.1

#### Smoking Signage

No Smoking signs shall be posted.

#### 2.8.3.2

#### Exit Signage

Exits shall be easily distinguishable for the public. All newly placed decorative items shall be California State Fire Marshal Certified or treated by a licensed and approved company and shall not cover exits and/or exit signs. Required exits shall comply to Chapter 10 of Building Code (door swing, door width, hardware). Exit sign illumination shall be provided per CFC 3103.12.7.

# LIGHTING & SOUND DEVICES



NOT ESSENTIAL FOR OPERATION, however, all lighting and sound devices shall comply with the section below. The lighting and sound guidelines have been designed to ensure responsible use of these devices.

### 2.9.1

( ) TBD

#### Electrical Supply

Lighting / electrical power shall be installed in accordance to electrical code.

### 2.9.2

( ) TBD

#### Task Lighting

TBD.

### 2.9.3

( ) TBD

#### Overhead Lighting

TBD.

### 2.9.4

( ) TBD

#### Amplified Sound

TBD.

### 2.9.5

( ) TBD

#### Not-In-Use Storage

TBD.

# HEATING & COOLING DEVICES



NOT ESSENTIAL FOR OPERATION, however, all heating and cooling devices shall comply with the section below. The heating and cooling guidelines have been designed to ensure safe use of these devices.

### 2.10.1

( ) TBD

#### Propane Heating Devices

Propane heating devices, including LPG heaters, are prohibited in any parklet with an overhead canopy. LPG cylinders shall be secured from being tipped over via crate, straps, or nesting. LPG cylinders shall not be placed near heating equipment, exits. LPG cylinders shall not be stored indoors or under structures or temporary membrane structures. LPG and natural gas heaters shall have a 5 foot clearance from combustibles.

### 2.10.2

( ) TBD

#### Electric Heating Devices

Electrical heaters shall have a minimum of 3 foot clearance from combustibles.

### 2.10.3

( ) TBD

#### Electric Fans

TBD.

### 2.10.4

( ) TBD

#### Not-In-Use Storage

TBD.

# **Attachment 2**

## OUTREACH

---

THREE  
**GROUP STAKEHOLDERS  
OUTREACH MEETINGS**  
WERE CONDUCTED  
DURING THE WEEK OF  
MARCH 20, 2023.

A TOTAL OF  
**12 BUSINESSES**  
**PARTICIPATED.**

THE FOLLOWING IS  
A SUMMARY OF  
**WHAT WE HEARD:**

- 1 The draft guidelines format is easy to follow.
- 2 The cost of fees will be instrumental in decision making to continue with the program.
- 3 What are the costs for the 'Kit of parts'? Will the City offer a list of pre-approved fabricators, can the City negotiate a better rates since the components may be able to be mass produced?
- 4 The guidelines are well done and important for setting higher aesthetic standards.
- 5 Realistically, when will the transitioning to the new program start?
- 6 For businesses ready to start, can application be submitted before the September 30th date?
- 7 Retractable shade options are desirable to alleviate impact from inclement weather.